



Health

Certificate of Accreditation

Sewage Management Facility

Aerated Wastewater Treatment System

This Certificate of Accreditation is issued by the Secretary of the NSW Ministry of Health pursuant to Clause 41(1) of the Local Government (General) Regulation 2005.

System: BioSeptic Performa AWTS

Manufacturer: BioSeptic Pty Ltd

*Of: 67 Smeaton Grange Road,
Smeaton Grange, NSW, 2567*

The BioSeptic Performa AWTS as described in Schedule 1, has been accredited as a sewage management facility for use in a single domestic premises in NSW. This accreditation is subject to the conditions of accreditation and permitted uses specified in Schedule 2.

*A/Director, Environmental Health
for Secretary (delegation PH335)*

Issued: 17 November 2015

Certificate No: AWTS 007

Expires: 31 December 2020

BioSeptic PERFORMA 10 Person AWTS

Ministry of Health Certificate of Accreditation - 007

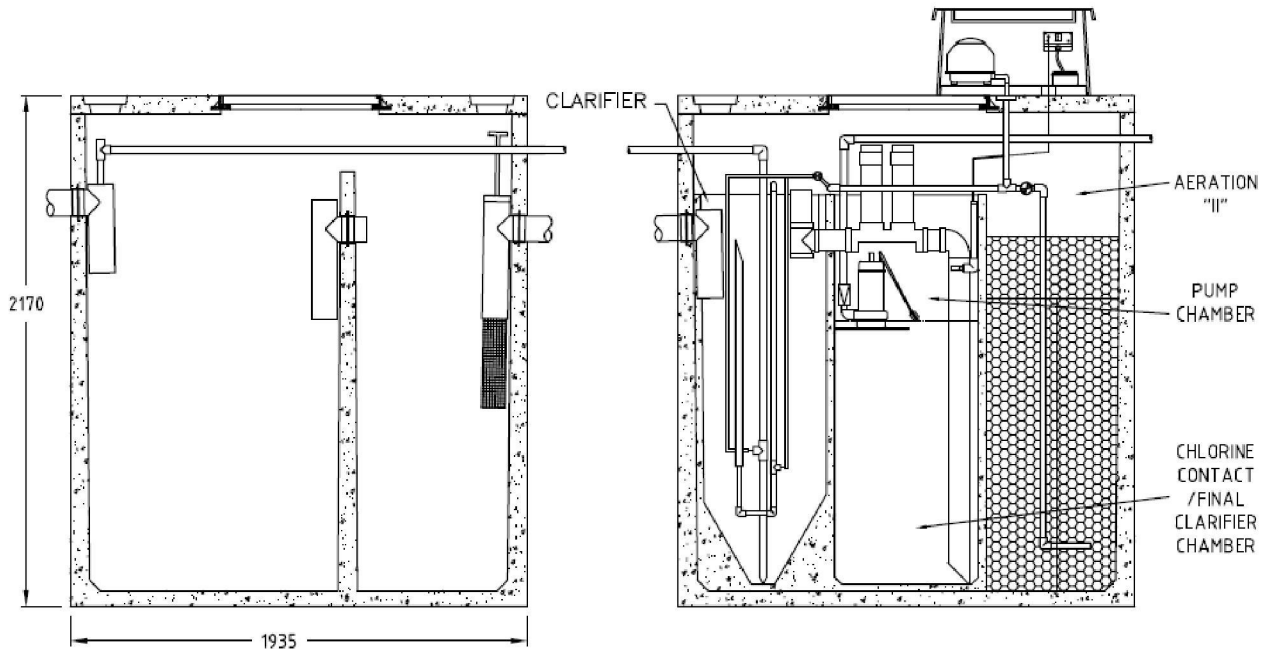
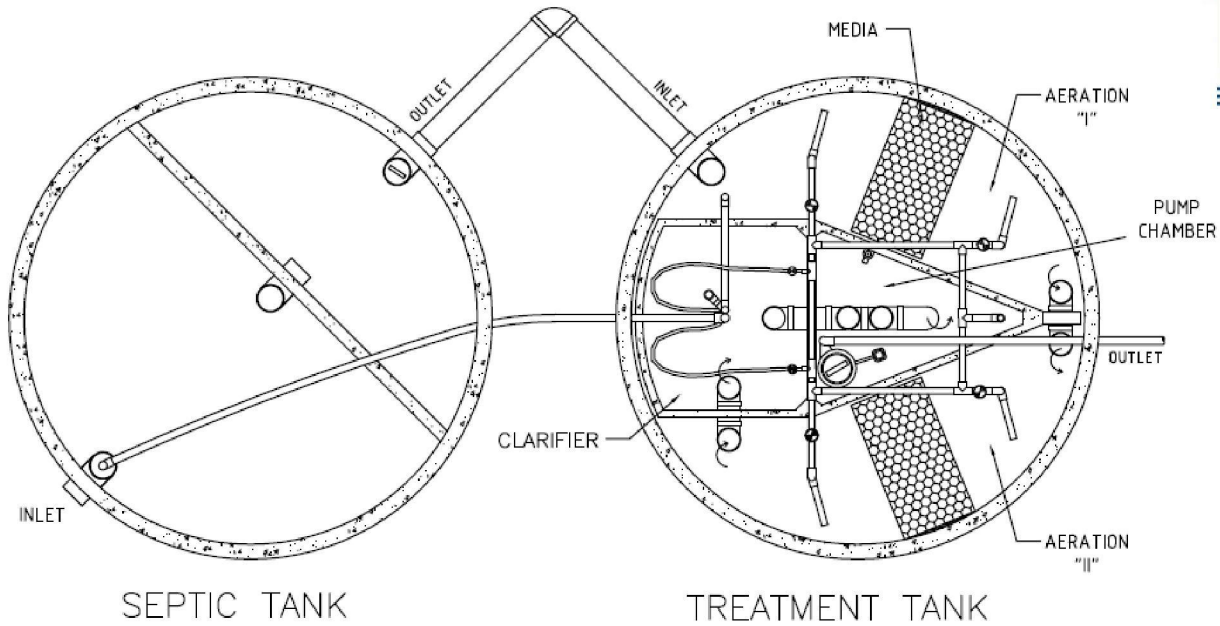

DESCRIPTION

- The BioSeptic Performa is a ten person aerated wastewater treatment system (AWTS)
- The BioSeptic Performa AWTS uses concrete tanks and chambers and has been in production since 1993.
- Ministry of Health Certificate of Accreditation – 007
- BioSeptic holds SAI Global third party accreditation for Product Certification to:
 - Ministry of Health aerated wastewater treatment systems (AWTS) Approval Guideline Part 3
 - AS/NZS1546.3 – On site domestic wastewater treatment systems
 - AS/NZS1546.1 – On site wastewater treatment systems
 - Part 1 septic tanks

Septic Tank	3550L
Aeration 1	1250 L
Aeration 2	1250 L
Clarifier	500 L
Chlorine Contact Chamber	300 L
Pump Chamber	100 L
Surcharge Volume	1050L
Tested at	2137 L/day



AS/NZS
1546.3
Lic No.
SMK 02221

BioSeptic Pty Ltd

ABN 95 056 461 226

67 Smeaton Grange Road, Smeaton Grange, NSW, 2567

Po Box 3250, Narellan, NSW, 2567

Ph: 1300 658 111 – Fax: 02 4629 6655

reception@bioseptic.com.au – www.bioseptic.com.au



AS/NZS
1546.1
Lic No.
SMKH21556



BioSeptic Pty Ltd
ABN 95 056 461 226
67 Smeaton Grange Road
Smeaton Grange NSW 2567
PO Box 3250, Narellan NSW 2567
Sales: 02 4629 6666
Service: 02 4629 6633
Fax: 02 4629 6655
reception@bioseptic.com.au
www.bioseptic.com.au



First Years' Service Agreement

Your local council requires that your BioSeptic system be correctly serviced every three months.

The first 4 services are complimentary and will be performed after BioSeptic Pty Limited (BioSeptic) receives all monies set out in the Sales Agreement. Thereafter, BioSeptic will offer to renew the Service Agreement each year.

The BioSeptic system has the following warranty dependent upon BioSeptic Pty Limited or its agent regularly maintaining the system:

1. 30 years Warranty - Concrete tank(s) and internal chambers
2. 5 years Warranty - Internal PVC pipe work and fittings
3. 1 year Warranty - Submersible pump(s), Aeration blower(s) & Control module
4. Additional year of warranty on pump(s) & blower(s) upon signing second year service agreement.

The warranty period commences from date the items are delivered and excludes any negligent damage on installation or incorrect usage of the system.

The period of the first years' service starts from the day that your system is given its first service, which is usually just before your house is occupied.

We at BioSeptic are committed to maintaining our good name and excellent service record, and we will ensure that your BioSeptic system is correctly and efficiently operating after every service.

The following items will be checked at each 3-monthly service:

- the efficiency of the chlorinator
- the chlorine tablets—replenishing as required
- the irrigation pump
- the operation of the blower (including changing the blower filter as necessary)
- the efficiency of the sludge and skimmer return system
- the condition of all pipes and hoses
- the efficiency of the irrigation sprays

The following items will be tested at each 3-monthly service:

- the high level water alarm
- the low air alarm
- the clarity of the water
- the pH level of the water
- the free residual chlorine level

The following annual check/test will be performed:

- observation of sludge accumulation in the septic tank