



TREVOR R HOWSE

DESIGN SPECIFICATION

ACCESSIBILITY



PREPARED FOR

Penrith City Council C/- Justin Long Design

REGARDING

1158-1160 Castlereagh Road, Castlereagh

BUILDING REGULATIONS • FIRE SAFETY ENGINEERING • LEGAL SERVICES

e admin@trevorhowse.com.au w www.trevorhowse.com.au a 27/16 Orchards Avenue, Breakfast Point, NSW, 2137

Report Register

The following report register documents the development and issue of this report and project as undertaken by this office, in accordance with the *Quality Assurance* policy of Trevor R Howse Pty Limited.

Our Ref.	Issue No.	Remarks	Issue Date
J18174(a)	1	Accessibility Specification completed	8.1.2019

The format, technical content and intellectual property associated with this report remain the property of Trevor R. Howse Pty Limited, and has been prepared, and may only be used, for the development / buildings the subject of this report.

Contents Page

Summary & Recommendations.....	4
1.1 Summary.....	4
1.2 Recommendations	5
Introduction	6
2.1 General	6
2.2 Specification Purpose	6
2.3 Specification Basis	7
2.4 Exclusions.....	7
2.5 Limitations.....	7
Building Description	9
3.1 General	9
3.2 Rise in Storeys	9
3.3 Building Classification.....	9
3.4 Effective Height.....	9
3.5 Type of Construction	9
3.6 General Floor Area Limitations.....	10
Disability Standard 2010 – Background.....	11
4.1 General	11
NCC 2016 Vol. 1 – Specification	17
4.1 General	17
4.2 Section D – Access & Egress	17
4.3 Section E – Services & Equipment.....	20
4.4 Section F – Health & Amenity.....	20
The Access Code – Specification.....	23
5.1 General	23
5.2 Part D3 – Access for people with a disability	23
5.3 Part D4 – Braille and tactile signs	24
5.4 Part D5 – Accessible water entry / exit for swimming pools	25
5.5 Part E3 – Lift installations.....	25
5.6 Part F2 – Sanitary and other facilities	26

Summary & Recommendations

1.1 Summary

This “Design Specification – Accessibility” has been prepared at the request of Penrith City Council C/- Justin Long Design.

It relates to the **Building Works Package** associated with the undertaking of alterations and additions to the existing building located at 1158-1160 Castlereagh Road, Castlereagh.

Figure 1.1.1 – Existing aerial photo



The purpose of this Design Specification is to –

- Identify those *primary* accessibility requirements of the National Construction Code 2016, Volume 1 (*NCC 2016 Vol. 1*) applicable to the proposed building work; and
- Identify those *primary* requirements contained within Schedule 1 of the Disability [Access to Premises] Standard 2010 (*The Access Code*) applicable to the proposed building work; and

- Form part of the overall package of approved documentation under a Building Application against which the works shall be undertaken, and inspected and certified at completion.

In reviewing the content of this report, it is highlighted that Compliance Structure of the NCC is as depicted in figure 1.1.2 below.

As this excerpt from the NCC 2016 Vol. 1 illustrates, a proposed design **must** comply with the applicable performance requirements.

It is a common misconception that a proposed design must comply with the deemed-to-satisfy provisions in the Code. The deemed-to-satisfy provisions are simply but one method of complying with the applicable performance requirements.

Figure 1.1.2 – NCC Compliance Structure

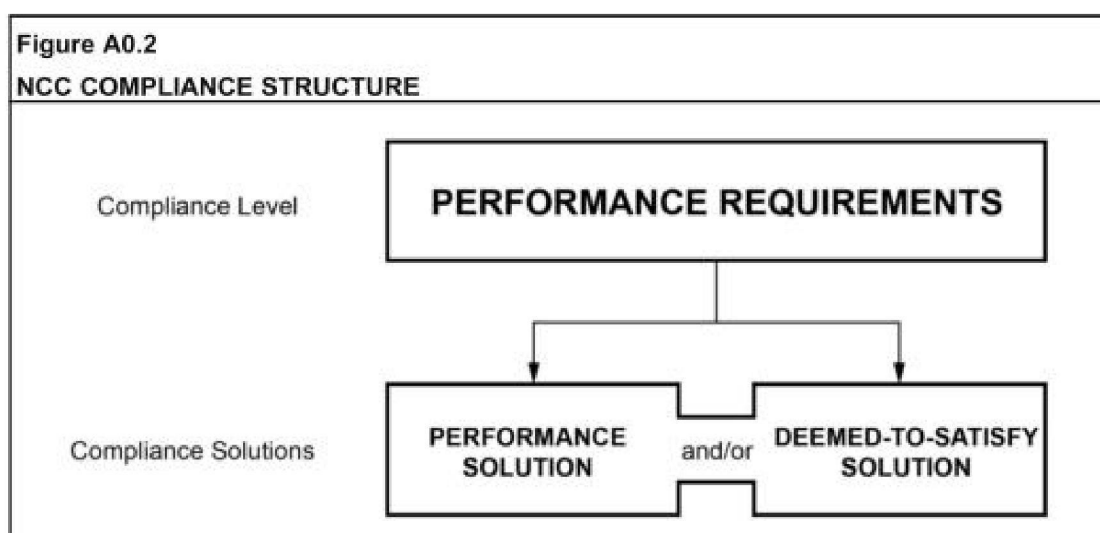

1.2 Recommendations

Undertake the proposed works in accordance with –

- The nominated documentation (item 2.3 of this report); and
- The NCC 2016 Vol. 1 prescribed requirements in Section 5 of this report; and
- The Access Code prescribed requirements in Section 6 of this report.

Particular attention is drawn to Clause D3.3 in Section 5 of this report.

Introduction

2.1 General

This "Design Specification – Accessibility" has been prepared at the request of Penrith City Council C/- Justin Long Design.

It relates to the **Building Works Package** associated with the undertaking of alterations and additions to the existing building located at 1158-1160 Castlereagh Road, Castlereagh.

Figure 2.1.1 –proposed floor plan

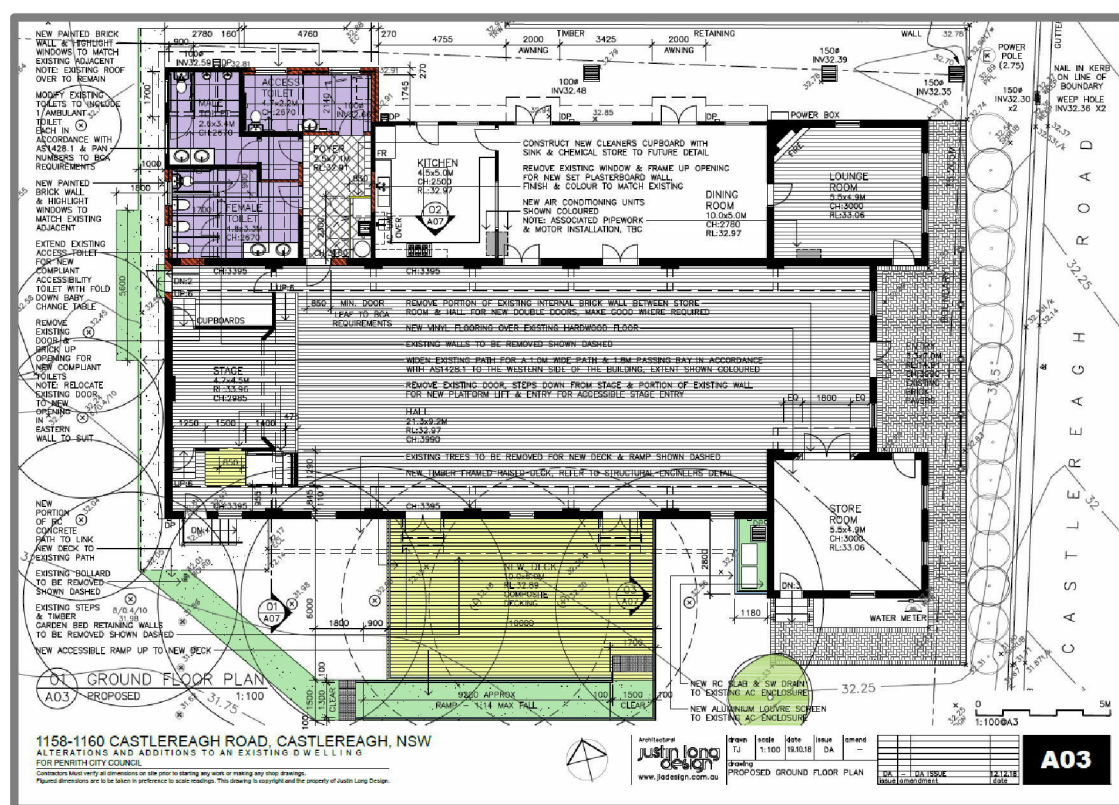

2.2 Specification Purpose

The purpose of this Design Specification is to –

- Identify those *primary* accessibility requirements of the NCC 2016 Vol. 1 applicable to the proposed building work; and
- Identify those *primary* requirements of The Access Code applicable to the proposed building work; and

- Form part of the overall package of approved documentation under a S109R Design Certificate against which the works shall be undertaken, and inspected and certified at completion.

2.3 Specification Basis

The content of this Specification ONLY reflects and relies upon –

- The Disability (Access to Premises) Standard 2010 (“Access Standard”);
- The accessibility provisions of Parts D3 and F2 of the National Construction Code Volume 1 (“NCC 2016 Vol. 1”); and
- Architectural documentation prepared by Justin Long Design –

DA

DA issue

12.12.2018

2.4 Exclusions

This Specification should also not be construed to infer that an assessment for compliance with the following has been undertaken –

- Structural design documentation;
- Mechanical, Hydraulic and Electrical services design documentation;
- The operational capacity / compliance of building services;
- The requirements of service providers (i.e. Telstra, Sydney Water, AGL);
- The requirements of the Work Cover Authority;
- The Disability Discrimination Act (DDA); and
- The non-accessibility provisions of NCC 2016 Vol. 1.

2.5 Limitations

It is conveyed that this Specification does not relieve any other party, including but not limited to architect, structural engineer, services consultant, authorities, and builder, from their responsibility to ensure the design and construction of the proposed works complies with the relevant Codes and Standards.

Additionally, while this Specification has been prepared to identify the *primary* prescriptive provisions of the NCC 2016 Vol. 1 and The Access Code applicable to the proposed design, it has NOT been compiled to document every individual detail (requirement) of those prescriptive provisions.

For more detailed information in respect of the design requirements of any prescriptive provisions listed (or not listed) in this Specification, project stakeholders need consult with our office or the relevant reference in the NCC 2016 Vol. 1 and The Access Code.

Building Description

3.1 General

The overall site is located at 1158-1160 Castlereagh Road, Castlereagh, and is bounded by –

- Castlereagh Road (to the east)
- Adjoining properties (to the north, south and west)

For the purposes of the NCC 2016 Vol. 1, the subject building is described within items 3.2 – 3.6 below.

3.2 Rise in Storeys

The existing building has a rise in storeys of one (1)

3.3 Building Classification

The existing building contains a single classification, namely –

- Class 9b – assembly

The proposed use is of a single classification, namely –

- Class 9b – assembly

3.4 Effective Height

This report is based upon the premise that the existing building has an effective height of less than 25-metres.

3.5 Type of Construction

The existing building is subject to the Type C Construction requirements of the BCA.

3.6 General Floor Area Limitations

The building in which the subject floors are contained are restricted to the following floor area and volume limitations for individual fire compartments –

- Class 9b
 - Floor area – 3,000 m²
 - Volume – 18,000 m³

Disability Standard 2010 – Background

4.1 General

The Disability [Access to Premises] Standard 2010 was, like the National Construction Code, formulated at the Commonwealth government level, to be applied in all States and Territories of Australia.

Consequently, in broad terms, the compliance standards now applied to a building project includes –

- The National Construction Code
- Development Consent / Complying Development conditions
- The Disability Standard 2010

The Disability Standard 2010 was promulgated under Section 31 of the “Disability Discrimination act 1992” (DDA), and took effect on 1 May 2011.

Building projects to which the Disability Standard 2010 are applicable, can be divided into three (3) categories, namely –

- A *new building*;
- A *new part*, and any *affected part*, of an existing building; and
- An *existing public transport building* that is still in use on any of the target dates mentioned in the table in Section 3.1 (Disability Standard 2010).

While each of these (and other) terms are defined within Part 1 of the Disability Standard 2010, several are summarised below –

“New building: Is a new building if –

(i) it is not a part of a building; and

(ii) either:

- 1. an application for approval for its construction is submitted, on or after 1 May 2011, to the competent authority in the State or Territory where the building is located; or*

2. *all of the following apply:*
 - A. *it is constructed for or on behalf of the Crown;*
 - B. *the construction commences on or after 1 May 2011;*
 - C. *no application for approval for the construction is submitted, before 1 May 2011, to the competent authority in the State or Territory where the building is located.*

New Part: *A part of a building is a new part of the building if it is an extension to the building or a modified part of the building about which –*

- (i) *an application for approval for the building work is submitted, on or after 1 May 2011, to the competent authority in the State or Territory where the building is located; or*
- (ii) *all of the following apply:*
 1. *the building work is carried out for or on behalf of the Crown;*
 2. *the building work commences on or after 1 May 2011;*
 3. *no application for approval for the building work is submitted, before 1 May 2011, to the competent authority in the State or Territory where the building is located.*

Affected part: *An affected part is –*

- (i) *the principal pedestrian entrance of an existing building that contains a new part; and*
- (ii) *any part of an existing building, that contains a new part, that is necessary to provide a continuous accessible path of travel from the entrance to the new part.”*

Building projects performed in any of these categories must comply with The Access Code.

The Access Code is contained within Schedule 1 of the Disability Standard 2010 and, like the access (disabled) provisions of the BCA, essentially provides specific criteria / characteristics required for inclusion within the proposed design for building works.

It is reasonable to conclude that compliance with the Deemed-to-Satisfy provisions in the Building Code of Australia (as is currently NCC 2016 Vol. 1) will ensure compliance with the Access Code in the Premises Standards. ^[1]

¹ Australian Human Rights Commission – Guideline on the application of the Premises Standard – 2011

However, it is important to note that there are differences in the application of the “Premises Standard” and the access (disabled) provisions of the NCC 2016 Vol. 1; these differences may be summarised as follows –

“The Premises Standards apply to the construction of new buildings and new parts of existing buildings. Unlike the Building Code of Australia (BCA), the Premises Standards also apply to a specified path of travel in an existing building (the ‘affected part’) and require a mandatory upgrade where that part does not comply with the Premises Standards.

The technical disability access requirements, which mirror the current disability access provisions of the BCA, are set out in Schedule 1 of the Premises Standards and are referred to as the Access Code for Buildings.

The Premises Standards do not apply to Class 1a buildings, or to a Class 10 building if it is associated with a Class 1a or a Class 4 building.

The Premises Standards also differ from the BCA with respect to how each applies to Class 1b and Class 2 buildings.”^[2]

There are two methods for achieving compliance with the Performance Requirements of the Access Code, as there are for achieving compliance with the NCC 2016 Vol. 1, namely –

- by using a ‘Deemed-to-Satisfy’ approach, or
- by meeting the Performance Requirements by using an alternative approach

Importantly, the Disability Standard 2010 also contains a number of exceptions and concessions. These are described in Part 4 of the Disability Standard 2010 and encompass the following categories –

- Unjustifiable hardship
- Acts done under statutory authority
- Lessees
- Lift concession
- Toilet concession

² Building Professionals Board – BPB Practice Advice PS11-001 – December 2011

The extent to which the content of these exceptions and concessions apply to a specific building project should be assessed on a project-specific basis. However, the following provides some general commentary relevant to application –

- Unjustifiable hardship

Where compliance with the Standards would impose an unjustifiable hardship on a person, the person does not have to comply with the Standards.

However, the person must comply with the Premises Standards to the maximum extent that does not involve unjustifiable hardship.

The circumstances which may constitute unjustifiable hardship are set out in Part 4.1 of the Disability Standard 2010 and include –

- (i) the financial position of the person required to comply with the requirement;
- (ii) any exceptional technical factors (such as the effect of load bearing elements on the structural integrity of the building) or geographic factors (such as gradient or topography);
- (iii) whether the costs of alterations to make a premises accessible is disproportionate to the value of the building;
- (iv) the benefits to the building owner or people with a disability to either comply or not comply with the Premises Standards.

Unjustifiable hardship does not apply to non-compliance with the Building Code of Australia, nor to non-compliance with a condition of development consent in relation to access or facilities for people with a disability. ^[3]

- Acts done under statutory authority

Section 4.2 of the Disability Standard 2010 preserves the general exemption under the DDA in relation to anything done in direct compliance with, for example, an order of a court or another law that has been prescribed under the DDA. ^[4]

- Lessees

Where an existing building is upgraded or extended in a way that triggers the requirement for a building approval, the Disability Standard 2010 will generally require an upgrade of the 'affected part' of the building.

This will entail the provision of a continuous accessible path of travel between the principal pedestrian entrance and the new part of the building.

Section 4.3 of the Disability Standard 2010 provides a limited concession from this requirement.

³ Building Professionals Board – BPB Practice Advice PS11-004 – December 2011

⁴ Australian Human Rights Commission – Guideline on the application of the Premises Standard – 2011

Where a building is occupied by a number of lessees (i.e. by 2 or more lessees), and an application for approval of building work is made by one of the lessees for work on the area of the building that they lease, there is no requirement on the lessee or any other person to provide a continuous accessible path of travel to the area of new work which the person leases.

For example, if one of a number of lessees to a building applies for an approval for a renovation of the sixth level of an existing multi-storey building, and this approval triggers the application of the Disability Standard 2010, then the lessee would only need to upgrade the area subject to the building approval.

That is, the lessee would not need to provide an accessible path of travel from the entrance to the building to the sixth floor (the affected part).

If the application for the renovation of the sixth floor included renovation of the toilets within the leased area, the lessee would be required to upgrade those toilets to meet the Disability Standard 2010 requirements (subject to any other concession which might apply to existing accessible toilets below).

This concession recognises that the lessee generally has no control over those parts of a building which they do not lease, such as the common areas of a building.

If the building application extends beyond the area of the building leased by the applicant, the concession will not apply to the path of travel to those areas.

The concession will not apply if the building is leased to only one person or entity or if the application for building approval is made by the owner of the building.⁵

- Lift concession

Section 4.4 of the Disability Standard 2010 provides a concession from the requirements of Table E3.6 (b) of the Access Code in relation to lift dimensions for existing lifts.

Where an existing lift travels more than 12 metres and has a lift floor of not less than 1100 mm by 1400 mm (i.e. if it complies with access requirements imposed by the BCA prior to the commencement of the Disability Standard 2010), it does not have to meet the usual Access Code requirements.

The Premises Standards would otherwise require the floor space of a lift that travels more than 12 metres to be a minimum of 1400 mm by 1600 mm.

This concession recognises that the earlier access requirements for lifts under the BCA only required floor dimensions of 1100 mm by 1400 mm and that rebuilding a lift shaft to house the larger lift floor dimensions could impose an unreasonable cost.

⁵ Australian Human Rights Commission – Guideline on the application of the Premises Standard – 2011

Other access features on a lift undergoing upgrade required by Table E3.6 (b), such as requirements for accessible lift controls and provision of audible information are not affected by this concession and must be provided.

It is intended that this concession will be addressed through changes to state and territory building legislation or regulation. ^[6]

- Toilet concession

Section 4.5 of the Disability Standard 2010 provides a concession for existing accessible sanitary compartments. The concession states that certain existing accessible sanitary compartments do not have to comply with AS 1428.1–2009 as generally required by the Access Code.

The concession, however, is available only where an existing sanitary compartment complies with the circulation and fit out requirements of AS 1428.1–2001 and is in a ‘new part’, or an ‘affected part’, of an existing building.

If an existing accessible sanitary compartment is in a ‘new part’ or ‘affected part’ of a building (and triggers a requirement for upgrading) and does not meet the requirements of AS1428.1–2001, it would be required to upgrade to meet the requirements of AS 1428.1–2009.

This concession recognises that the significant cost of upgrading the circulation space in existing sanitary facilities would not be justified where those facilities meet previous accessibility requirements. ^[7]

⁶ Australian Human Rights Commission – Guideline on the application of the Premises Standard – 2011

⁷ Australian Human Rights Commission – Guideline on the application of the Premises Standard – 2011

NCC 2016 Vol. 1 – Specification

4.1 General

The following accessibility prescriptive provisions of the NCC 2016 Vol. 1 are applicable to the proposed building works.

In each instance, the *primary* requirements of these prescriptive provisions are highlighted in the comments provided below.

As these comments are not necessarily exhaustive, for more detailed design information, the corresponding clause reference in the NCC 2016 Vol. 1 should be consulted by the project team / stakeholders.

4.2 Section D – Access & Egress

- Clause D3.3 – Parts of buildings to be accessible

AS 1428.1-2009 compliant access for people with a disability is to be provided to and within all parts.

This necessitates the provision of the following characteristics –

- (a) An unobstructed opening width to all new doorways, of not less than 850-mm
- (b) Floor surfaces, including changes in level, must be AS 1428.1-2009 compliant in terms of being non-slip;
- (c) New door hardware must be installed as per AS 1428.1-2009 (i.e. located between 900-1100-mm above the floor, have a gap between the back of the handle and the face of the door leaf of 35-45-mm);
- (d) AS 1428.1-2009 compliant turning spaces within 2-metres of dead-ends in accessways, where it is not possible to continue along the accessway;
- (e) All new non-power operated swing and sliding door leafs must be provided with AS 1428.1-2009 compliant circulation space to both sides of the opening.
- (f) All new doorways must have a minimum luminance contrast of 30% provided between either the –
 - 1. door leaf and door jamb;
 - 2. door leaf and adjacent wall;
 - 3. achitrave and wall;
 - 4. door leaf and architrave; or

5. door jamb and adjacent wall.

The minimum width of the area of luminance contrast must not be less than 50-mm.

- (g) Power operated doors must be operated by automatic sensor or push button controls installed as per clause 13.5.3 and 13.5.4 of AS 1428.1-2009.

Such manual controls must be –

1. located on the continuous accessible path of travel
2. no closer than 500 mm from an internal corner
3. between 1000 mm to 2000 mm from the hinged door leaf in any position or clear of a surface-mounted sliding door in the open position.

The following excerpt from AS 1428.1-2009 illustrates the dimensions of the turning space referred to in item (d) above

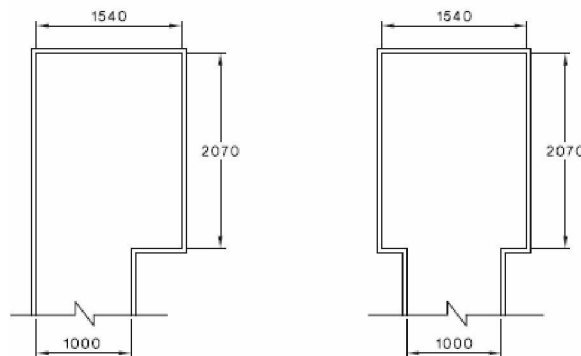

Having regard to this, the following observations are extended –

- (a) The retained double door leafs opening from the building opening from the hall out onto the new deck do not appear to have an individual door leaf not less than 850-mm (clear opening) in each doorway opening
- (b) The proposed ramp shall have a length longer than 9-metres without an intermediate landing
- (c) The balustrade to perimeter of the new deck and the ramp need be designed and constructed to AS 1428.1-2009, as includes the provision of kerb rails

- **Clause D3.6 – Signage**

- (a) The proposed accessible and ambulant sanitary facilities must be provided with BCA Specification D3.6 compliant tactile and braille signage incorporating the International Symbol of Access;
- (b) The exit doors from the building must be provided with BCA Specification D3.6 compliant signage stating “EXIT” and “LEVEL” followed by the floor level number or floor level descriptor.



- **Clause D3.8 – Tactile indicators**

AS/NZS 1428.4.1 compliant tactile ground surface indicators are to be provided to the top and bottom of the new ramp.

Having regard to this, the following observations are extended –

- (a) The tactiles depicted at the top of the ramp, appear to be more than 300-mm from the top of the rap (where it meets the landing)

- **Clause D3.12 – Glazing on an accessway**

All frameless or fully glazed doors, sidelights and any glazing capable of being mistaken for a doorway or opening, must be clearly marked in accordance with AS 1428.1-2009.

Markings must be solid, non-transparent and contrasting, and must extend the full width of the glazing panel(s).

The contrasting line shall be not less than 75 mm wide and shall extend across the full width of the glazing panel.

The lower edge of the contrasting line shall be located between 900 mm and 1000 mm above the plane of the finished floor level.

4.3 Section E – Services & Equipment

- Clause E3.6 – Passenger lifts

The proposed low-rise platform lift providing access onto the stage need have the following characteristics –

- Have AS 1735.12 compliant handrails
- Have a floor dimension not less than 1100-mm wide x 1400-mm deep
- Have AS 1735.12 compliant doorway opening
- Emergency hands-free communication.

4.4 Section F – Health & Amenity

- Clause F2.4 – accessible sanitary facilities

The proposed works depict the provision of two (2) new ambulant cubicles and one (1) new accessible sanitary facility.

Both the proposed ambulant and accessible cubicles need comply with AS 1428.1-2009 (see also figures 4.4.1 and 4.4.2 below).

Diagram 4.4.1

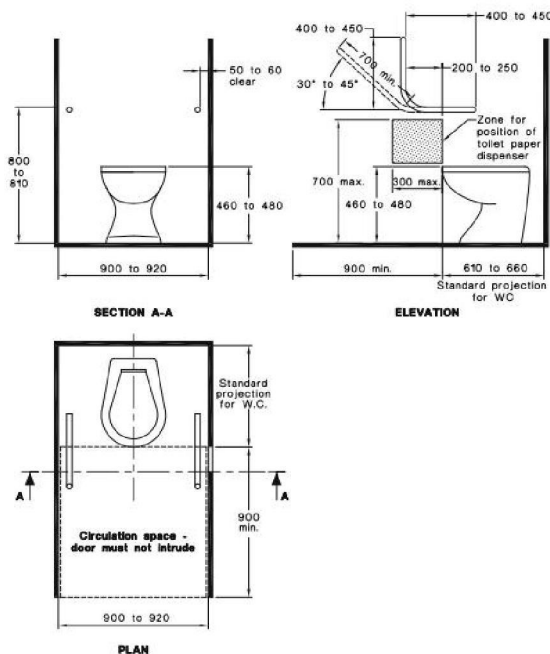
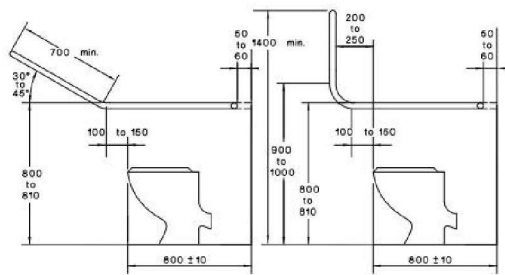
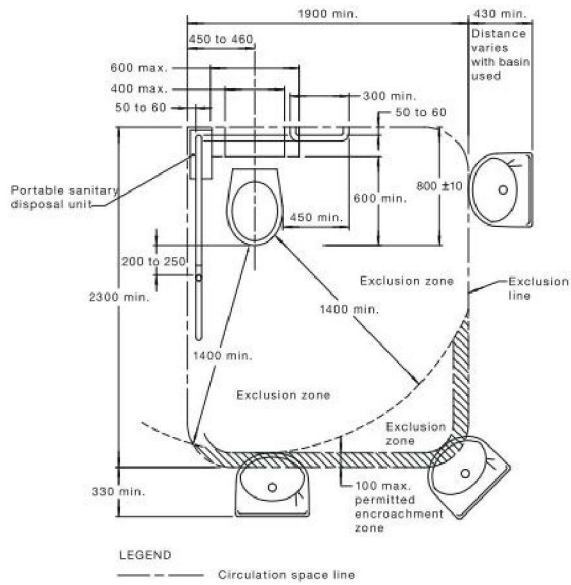
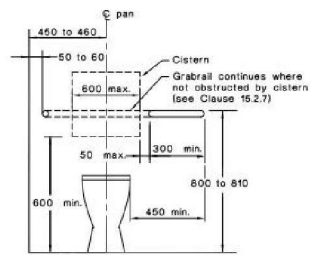

Diagram 4.4.2



(i) Option A (ii) Option B
 (a) Side view showing optional systems for grabrail at sides of pan



(b) Grabrail at back of pan and sectional view of grabrail at side of pan

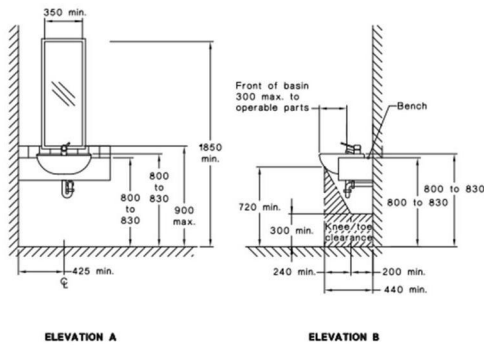

ELEVATION A

ELEVATION B

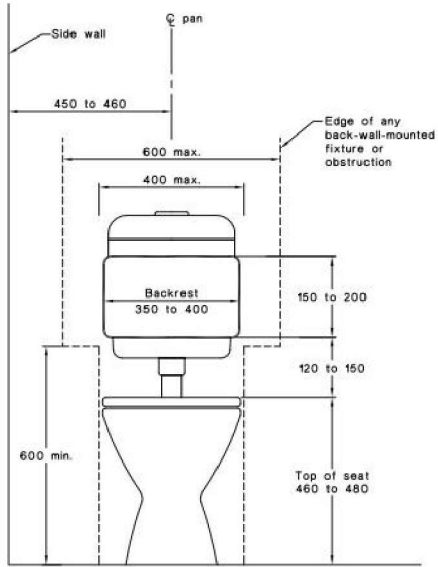

(a) Front view

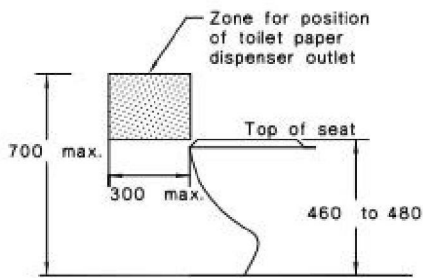

DIMENSIONS IN MILLIMETRES

The Access Code – Specification

5.1 General

The following accessibility prescriptive provisions of The Access Code are applicable to the proposed building works.

In each instance, the *primary* requirements of these prescriptive provisions are highlighted in the comments provided below.

As these comments are not necessarily exhaustive, for more detailed design information, the corresponding clause reference in The Access Code should be consulted by the project team / stakeholders.

5.2 Part D3 – Access for people with a disability

- **Clause D3.3 – Parts of buildings to be accessible**

As per Clause D3.3 in item 4.2 of this report above.

- **Clause D3.6 – Signage**

As per Clause D3.6 in item 4.2 of this report above.

- **Clause D3.8 – Tactile indicators**

As per Clause D3.8 in item 4.2 of this report above.

- **Clause D3.12 – Glazing on an accessway**

As per Clause D3.12 in item 4.2 of this report above.

5.3 Part D4 – Braille and tactile signs

- **Clause D4.2 – location of braille and tactile signs**

In respect of the signage described in NCC 2016, Vol 1 Clause D3.6 above, the symbols, numbering and lettering must be designed and installed as follows –

- (a) braille and tactile components of a sign must be located not less than 1 200 mm and not higher than 1600 mm above the floor or ground surface;
- (b) signs with single lines of characters must have the line of tactile characters not less than 1250 mm and not more than 1350 mm above the floor or ground surface;
- (c) signs identifying rooms containing features or facilities listed in clause D3.6 must be located:
 1. on the wall on the latch side of the door with the leading edge of the sign located between 50 mm and 300 mm from the architrave; and
 2. where 1 above is not possible, the sign may be placed on the door itself.

- **Clause D4.3 – braille and tactile sign specification**

- (a) Tactile characters must be raised or embossed to a height of not less than 1 mm and not more than 1.5 mm.
- (b) Sentence case (upper case for the first letter of each main word and lower case for all other letters) must be used for all tactile characters; and
 1. upper case tactile characters must have a height of not less than 15 mm and not more than 55 mm; and
 2. lower case tactile characters must have a height of 50% of the related upper case characters.
- (c) Tactile characters, symbols, and the like, must have rounded edges.
- (d) The entire sign, including any frame, must have all edges rounded.
- (e) The background, negative space or fill of signs must be of matt or low sheen finish.
- (f) The characters, symbols, logos and other features on signs must be matt or low sheen finish.
- (g) The minimum letter spacing of tactile characters on signs must be 2 mm.
- (h) The minimum word spacing of tactile characters on signs must be 10mm.
- (i) The thickness of letter strokes must be not less than 2 mm and not more than 7 mm.
- (j) Tactile text must be left justified, except that single words may be centre justified.

Tactile text must be Arial typeface.

- **Clause D4.4 – luminance contrast**

The following apply to luminance contrast:

- (a) the background, negative space, fill of a sign or border with a minimum width of 5 mm must have a luminance contrast with the surface on which it is mounted of not less than 30%;
- (b) tactile characters, icons and symbols must have a minimum luminance contrast of 30% to the surface on which the characters are mounted;
- (c) luminance contrasts must be met under the lighting conditions in which the sign is to be located.

- **Clause D4.5 – lighting**

Braille and tactile signs must be illuminated to ensure *luminance contrast* requirements are met at all times during which the sign is required to be read.

- **Clause D4.6 – braille**

The following applies to braille –

- (a) braille must be grade 1 braille (uncontracted) in accordance with the criteria set out by the Australian Braille Authority;
- (b) braille must be raised and domed;
- (c) braille must be located 8 mm below the bottom line of text (not including descenders);
- (d) braille must be left justified;
- (e) where an arrow is used in the tactile sign, a solid arrow must be provided for braille readers;
- (f) on signs with multiple lines of text and characters, a semicircular braille locator at the left margin must be horizontally aligned with the first line of braille text.

5.4 Part D5 – Accessible water entry / exit for swimming pools

Not applicable to the proposed works.

5.5 Part E3 – Lift installations

- **Clause E3.6 – Passenger lifts**

As per Clause E3.6 in item 4.3 of this report above.

5.6 Part F2 – Sanitary and other facilities

- Clause F2.4 – accessible sanitary facilities

As per Clause F2.4 in item 4.4 of this report above.