

Introduction

This data sheet contains TQ's recommendations for residential timber decks, verandahs, patios etc which are exposed to the weather. It covers the most common timber species and deck sizes.

For alternative sizes, spans and stress grades refer to AS 1684 Residential timber-framed construction. For commercial and industrial decks, refer to Technical Data Sheet 7. For decks close to the ground (i.e. framing less than 400 mm above ground), refer to Technical Data Sheet 13. For timber handrails and balustrades, refer Technical Data Sheet 23.

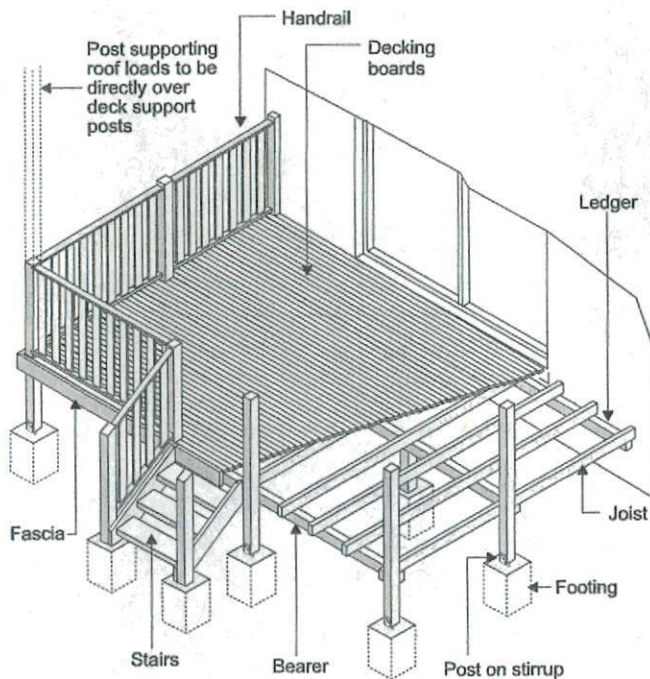

Timber Selection

Posts in contact with the ground shall be either preservative treated pine or In-ground Durability Class 1 hardwood, with any sapwood preservative treated. Some In-ground Durability Class 2 hardwoods and cypress (refer Table 1) may be used for in-ground applications if they can be easily replaced should decay occur.

Decking and deck framing above ground shall be either cypress, preservative treated pine or Above Ground Durability Class 1 hardwood. Hardwood decking boards and deck framing containing sapwood must be preservative treated.

Preservative treatment for posts in the ground and framing on the ground, shall be to hazard level H5. Preservative treatment for framing more than 150 mm above ground shall be H3.

Table 1 Species Selection

Species	Posts in Ground	Post and Framing Above Ground	Decking
PRESERVATIVE TREATED PINE (Carribean, Hoop, Radiata, Slash)	✓H5 Treatment	✓H3 Treatment	✓H3 Treatment (See Note 2)
MIXED OPEN FOREST HARDWOODS (QLD, Nthn. NSW)	(See Note 1)	✓	✓
BALAU Yellow			✓
BELIAN			✓
BLACKBUTT	(See Note 1)	✓	✓
CYPRESS (Sapwood Free)*		✓	✓
GUM Forest Red	✓	✓	✓
GUM Grey	✓	✓	✓
GUM Spotted	(See Note 1)	✓	✓
IRONBARK Red or Grey	✓	✓	✓
KWILA (MERBAU)			✓
MAHOGANY Red	(See Note 1)	✓	✓
MAHOGANY White	✓	✓	✓
MESSMATE Gympie	✓	✓	✓
TALLOWOOD	✓	✓	✓
TURPENTINE	✓	✓	✓

* See Note 1

Note:

- These timbers should only be used for in-ground applications if they can be easily replaced if degrade occurs.
- CCA treated timber shall not be used for domestic decking boards

Cypress framing may contain limited amounts of sapwood (max. 25% width of face or edge) provided the sapwood does not occur at joints or fixing points.

Cypress decking shall be Grade No. 1 in accordance with AS 1810. Sapwood in cypress decking boards shall face downward and be below or as close as possible to any eaves or roof projection.

Hardwood decking shall be standard (medium feature) grade or select grade in accordance with AS 2796. Select grade decking is recommended in fully weather exposed situations. Softwood decking shall comply with the grading rules for Pine Timber Products.

Decking boards shall be seasoned to the requirements of the applicable Australian Standard (i.e. Hardwood 10% to 18%, Softwood 10% to 15%).

Note: TQL recommends a maximum MC of 15% for residential decking.

Table 2 Timber Posts Supporting Roof and/or Floor Loads

		Floor Area Supported (m ²)	5				10				15			
		Roof Area Supported (m ²)	0	5	10	20	0	5	10	20	0	5	10	20
		Member Size	Maximum Post Height (mm)											
Unseasoned Cypress, F5	Sheet Roof	75 x 75 100 x 100	4800 4800	3800 4300	2700 3000	1900 2100	1900 2100	1700 2000	1600 1900	1400 1700	NS NS	NS NS	NS NS	NS NS
	Tile Roof	75 x 75 100 x 100	4800 4800	2600 4600	1800 3200	1200 2300	1800 3300	1600 2900	1300 2600	900 2100	NS 1500	NS 1300	NS NS	NS NS
Seasoned Treated Pine, F7	Sheet Roof	70 x 70 90 x 90	4800 4800	4100 4800	2900 4800	2000 3400	1900 3200	1800 3000	1700 2900	1500 2600	NS 1600	NS 1500	NS 1400	NS 1300
	Tile Roof	70 x 70 90 x 90	4800 4800	2900 4800	2100 3400	1400 2400	1900 3200	1700 2800	1500 2600	1100 2200	NS 1600	NS 1400	NS 1300	NS NS
Unseasoned Hardwood, F14	Sheet Roof	75 x 75 100 x 100	4800 4800	4800 4800	3700 4800	2600 4600	2600 4600	2500 4300	2300 4100	2100 3700	1500 2600	1400 2600	1400 2500	1300 2400
	Tile Roof	75 x 75 100 x 100	4800 4800	3700 4800	2600 3700	1800 2600	2600 4600	2300 4000	2100 3600	1700 3000	1500 2600	1400 2500	1300 2400	1100 2200
Treated Pine Rounds F8	Sheet Roof	100 dia 125 dia 150 dia	2100 3600 4800	2000 3400 4800	1900 3200 4800	1800 2900 4800	1500 2500 4500	1400 2400 4300	1300 2400 4200	1200 2300 4000	900 2000 3600	NS 2000 3600	NS 1900 3500	NS 1800 3400
	Tile Roof	100 dia 125 dia 150 dia	2100 3600 4800	1900 3200 4800	1700 2900 4800	1400 2500 4400	1400 2500 4500	1300 2400 4200	1200 2200 4000	900 2000 3600	NS 2000 3600	NS 1900 3500	NS 1800 3400	NS 1600 3100

Table 3 Bearers

	Member Size (mm)	Floor Load Width (mm) (Length of joists supported)							
		1800	2400	3000	3600	1800	2400	3000	3600
		Maximum Bearer Span (mm)							
		Single Span				Continuous Span			
Unseasoned Cypress, F5	100 x 75	1000	NS	NS	NS	1000	NS	NS	NS
	2/100 x 50	1300	1100	900	NS	1300	1100	900	900
	125 x 75	1300	1100	1000	1100	1300	1100	1000	NS
	2/125 x 50	1600	1400	1300	1100	1600	1400	1300	1100
	150 x 75	1600	1300	1200	1350	1600	1300	1200	1100
	2/150 x 50	1950	1650	1500	1300	1950	1650	1500	1350
	175 x 75	1800	1600	1400	1300	1800	1600	1400	1300
	2/175 x 50	2200	1900	1700	1600	2200	1900	1700	1600
	200 x 75	2100	1800	1600	1500	2100	1800	1600	1500
	2/200 x 50	2600	2200	2000	1800	2600	2200	2000	1800
Seasoned Treated Pine, F7	140 x 45	1300	1100	1000	900	1300	1100	1000	900
	2/140 x 35	1700	1500	1300	1200	1700	1500	1300	1200
	2/140 x 45	2000	1700	1500	1400	2000	1700	1500	1400
	190 x 45	1750	1500	1350	1200	1750	1500	1350	1200
	2/190 x 35	2400	2000	1800	1600	2400	2000	1800	1600
	2/190 x 45	2700	2300	2100	1900	2700	2300	2100	1900
	240 x 45	2200	1900	1700	1550	2200	1900	1700	1550
	2/240 x 35	3000	2600	2300	2100	3000	2600	2300	2100
	2/240 x 45	3400	2900	2600	2400	3400	2900	2600	2400
	Unseasoned Hardwood, F14	100 x 75	1700	1400	1300	1100	1700	1400	1300
2/100 x 50		1900	1700	1600	1400	2100	1800	1600	1400
125 x 75		2100	1800	1600	1500	2100	1800	1600	1500
2/125 x 50		2400	2200	2000	1800	2600	2300	2000	1800
150 x 75		2500	2200	1900	1800	2500	2200	1900	1800
2/150 x 50		2900	2600	2400	2200	3100	2700	2400	2200
175 x 75		2900	2600	2300	2100	2900	2600	2300	2100
2/175 x 50		3300	3000	2800	2600	3700	3200	2800	2600
200 x 75		3400	2900	2600	2400	3400	2900	2600	2400
2/200 x 50		3700	3400	3200	3000	4200	3600	3200	3000

Notes:

1. Bearers to support floor loads only. Posts supporting roof to be directly over deck supports.
2. Maximum cantilever can be 25% of allowable span provided the actual backspan is at least twice the actual cantilever.
3. Sizes greater than 200 mm deep may not be readily available.
4. For other stress grades and sizes refer to AS1684 Residential timber-framed construction.

Table 4 Floor Joists (450 mm spacing)

	Member Size (mm)	Maximum Floor Joist Span (mm)	
		Single Span	Continuous
Unseasoned Cypress, F5	100 x 50	1400	1700
	125 x 50	2200	2200
	150 x 50	2600	2600
	175 x 50	3000	3000
	200 x 50	3500	3500
Seasoned Treated Pine, F7	90 x 45	1300	1700
	120 x 45	2200	2200
	140 x 45	2600	2600
	190 x 45	3600	3600
	240 x 45	4500	4500
Unseasoned Hardwood, F14	100 x 50	2200	2500
	125 x 50	2800	3200
	150 x 50	3400	3800
	175 x 50	3900	4500
	200 x 50	4400	5100

Notes:

- Joists to support floor loads only. Posts supporting roof to be directly over deck supports.
- Maximum cantilever can be 25% of allowable span provided the actual backspan is at least twice the actual cantilever.
- Sizes greater than 200 mm deep and 7200 mm long may not be readily available.
- 45/50 mm wide joists are recommended where decking boards are nail fixed to tops of joists. 35/38 mm wide joists are suitable where side of joist proprietary fixings (e.g. Deklok) are used.
- For other stress grades and sizes refer to AS 1684 Residential timber-framed construction.

Termite Protection

Physical and/or Chemical barriers must be provided to protect the deck and to ensure termites do not bypass protection systems to adjacent structures. Termite barriers must be designed so that they can be readily inspected and maintained.

Where adequate termite protection is not provided to decks, they shall be completely isolated from any adjacent structure.

Member Design

Tables 2, 3 and 4 list sizes for posts, bearers and joists, for common member spacings and commonly used timber stress grades.

The following tolerances apply:-

- Unseasoned Cypress + 2 mm - 4 mm
- Seasoned Pine + 2 mm - 0 mm
- Unseasoned Hardwood + 3 mm - 3 mm.

The sizes for bearers and joists do not allow for roof loads (i.e. posts supporting roof to be continuous to the ground or be positioned directly over deck supports) and are suitable for a maximum decking mass of 20 kg/m².

For alternative sizes, spans and stress grades or for members supporting roof loads, refer to AS 1684 Residential timber-framed construction.

Fixings

Post stirrups shall be hot dipped galvanised.

Bolts, screws and nails shall be hot dipped galvanised or stainless steel (not zinc plated).

Proprietary connectors (joist hangers, framing anchors, etc), in fully weather exposed situations, shall be either hot dipped galvanised, stainless steel or with a fused or baked epoxy coating in accordance with manufacturer's recommendations.

NOTES:

- Standard galvanised connectors (Z 275 class) are only recommended when weather protected (i.e. under roof).
- In corrosive environments (i.e. close to the coast, swimming pools, etc), higher levels of protection are required.
- The above recommendations apply to treated timber which remains dry in service. Proprietary connectors used with CCA, ACQ or copper azole treated timber, which remains moist (i.e. over 20% for extended periods), shall be either stainless steel or with a fused or baked epoxy coating (not standard or hot dipped galvanised).

Attaching Decks to House

Ledgers shall be a minimum 90 x 45 mm treated pine, hardwood or cypress, fixed to house framing (studs, joists or bearers) with 12 mm dia. hot dipped galvanised bolts or coach screws at 900 mm maximum spacing. Ledgers may be fixed with masonry anchors to structural brick or block walls in accordance with manufacturer's instructions.

Note: Brick veneer or other single skin brick walls may not be structurally adequate and require additional piers or freestanding posts.

Bracing

Decks shall be braced to prevent lateral movement. Timber braces shall be double diagonal 100 x 38 mm hardwood or 90 x 45 mm treated pine, halved at the crossing.

Decks attached to the house shall have double diagonal bracing either:

- fixed to the underside of joists with each brace fixed to each joist with 75 mm No. 14 Type 17 batten screws or two 75 x 3.15 mm nails, or
- for decks greater than 1800 mm high, fixed between a pair of posts, parallel to the wall, with the ends of braces bolted to posts with 12 mm dia. bolts.

Freestanding decks greater than 1800 mm high shall be braced in both directions with double diagonal braces between at least two pairs of posts at right angles. Freestanding decks less than 1800 mm shall have posts embedded in the ground to provide lateral bracing.

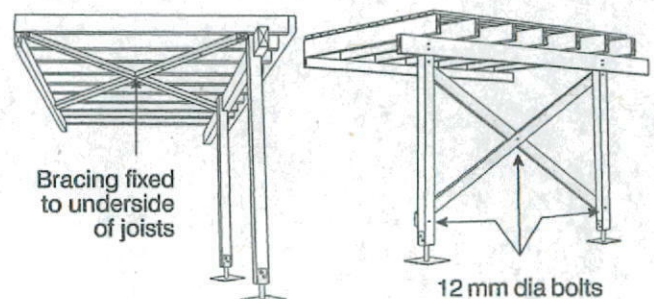

Installing Posts

Timber posts should preferably be fixed to hot dipped galvanised steel stirrups set in concrete. A minimum clearance of 75 mm shall be provided between the top of the concrete footing and the bottom of the post as a termite inspection zone.

Posts embedded in the ground shall be a durable species (refer Table 1). Holes for embedded posts shall be filled with 100 mm depth of coarse gravel (to allow water to drain) before backfilling with concrete or rammed earth. 'No fines' concrete is recommended for hardwood posts. Top of backfill to be sloped away from posts to shed water. Termite protection to embedded posts shall be provided by stainless steel mesh (Termimesh) socks or caps or by chemical treatment to the surrounding ground.

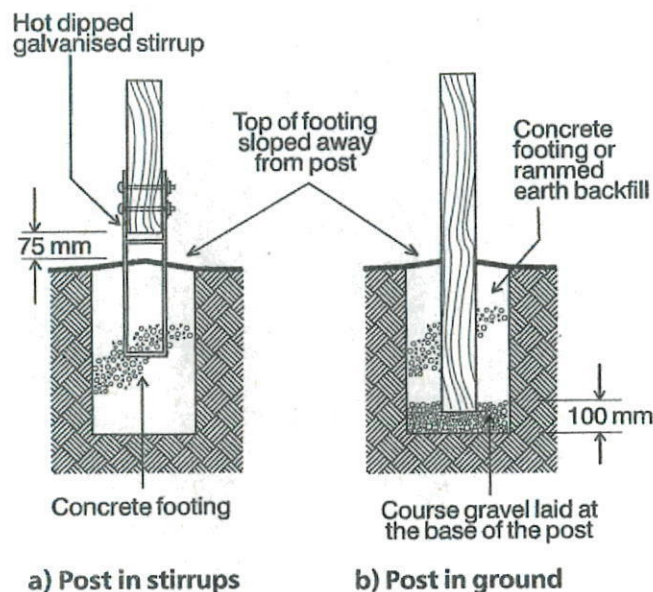

Installing Bearers

Bearers shall be adequately fixed to posts.

Either:-

- Where bearers sit on top of posts, fixed with proprietary post caps or brackets in accordance with manufacturer's instructions, or
- With bearers housed into posts and bolted with two 12 mm dia. bolts. (Minimum 35 mm of post to remain after housing), or
- For double bearers or where posts continue up to support handrails or roof, partially housed (10 mm nominal) into side of posts and bolted with two 12 mm dia. bolts.

Note: Housed joints shall be coated with water repellent preservatives or oil based primer

Seasoned double bearers may be either spaced or nail-laminated together with staggered nails, at a spacing equal to twice the bearer depth. Unseasoned double bearers shall be spaced. Where double bearers are spaced, solid timber spacing blocks shall be provided and bolted between the bearers at mid-span.

a) Typical proprietary bracket

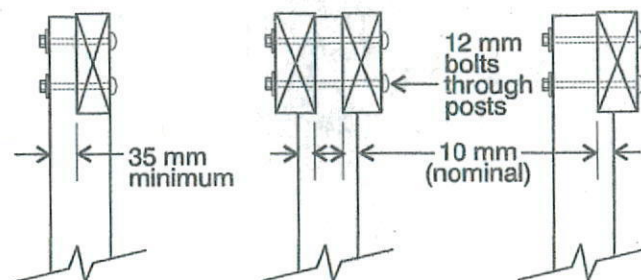
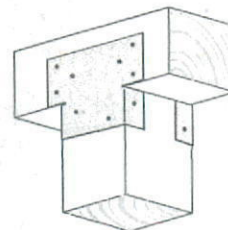

b) Bearers fully housed

c) Bearers partially housed

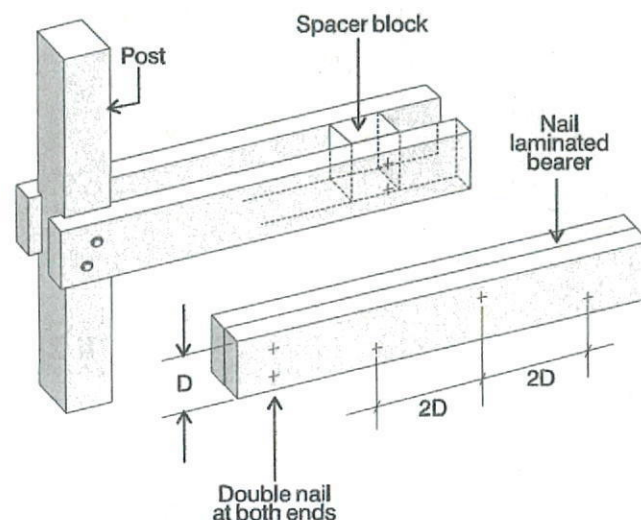

Installing Joists

Joists shall be fixed on top of bearers or ledgers at 450 mm maximum spacing with either two 75 mm x 3.15 mm skew nails or proprietary framing anchors or brackets.

Alternatively, joists may be installed in line with bearers and/or ledgers and fixed to proprietary joist hangers in accordance with manufacturer's recommendations.

Note: Nails for proprietary connectors to be hot dipped galvanised

Sizes shown in Table 4 list only 45 mm and 50 mm wide joists although 35/38 mm wide joists may be structurally adequate. Joists 45/50 mm wide are recommended because they are less prone to splitting and provide better bearing and fixing for decking boards at joins and ends. Joists 35/38 mm wide may be suitable for use where decking is fixed to sides of joists with proprietary fixings (e.g. Deklok). (Refer AS 1684 for larger range of joist sizes).

Where depth of joist is greater than four times the width, solid blocking shall be provided between joists at each support. For joists spans over 3 m, additional herringbone strutting or solid blocking should be provided in evenly spaced rows as follows:-

- For spans over 3.0 m to 4.2 m - one row
- For spans over 4.2 m - two rows equally spaced.

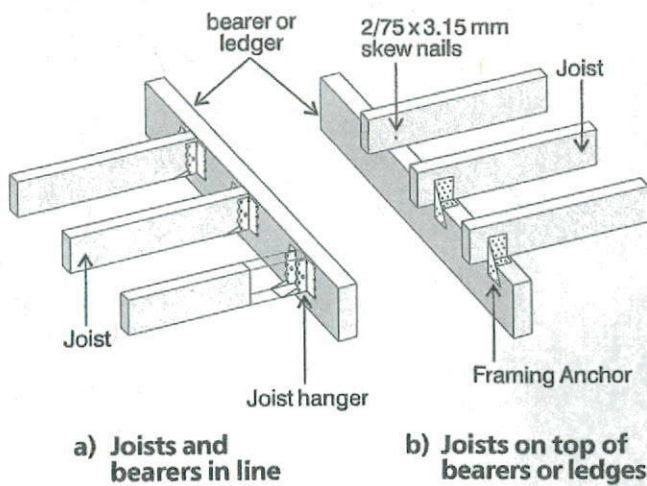

a) Joists and bearers in line

b) Joists on top of bearers or ledges

Decking

Decking boards are available plain (square edged), with pencil round or arised edges, or with one reeded or ribbed surface. Tongue and grooved flooring must not be used for weather exposed decks.

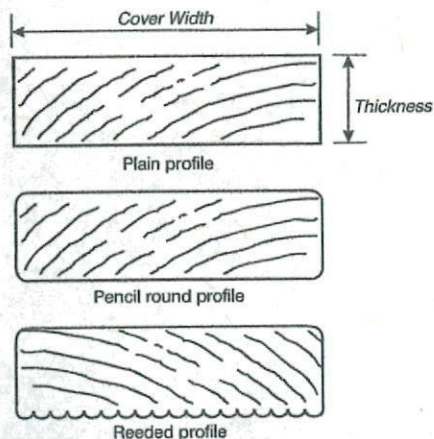

Standard thicknesses for decking are:-

Cypress	21mm
Treated Pine	22 mm
Hardwood	19 mm

Standard cover widths are:-

Cypress	68 mm
Treated Pine	70 mm or 90 mm
Hardwood	63 mm or 88 mm

Narrow boards are recommended as they shed water more readily and are therefore less prone to cupping and twisting.

Reeded or ribbed decking may be fixed with reeded face down or up (owners choice), however where fixed with reeded face up (as a "non-slip" surface), decking must be regularly maintained as build up of dirt and moulding in grooves can make surfaces more slippery and accelerate decay.

Decking boards shall be seasoned to the requirements of the applicable Australian Standard (i.e. hardwood 10% to 18%, softwood 10% to 15%). Note: TQL recommends a maximum MC of 15% for residential decking.

Installing Decking

The top surface of joists and all surfaces of decking boards shall have a coat of water repellent preservative or oil based primer plus one coat of the selected finish (paint or stain) applied before fixing decking (refer Finishes). Table 5 lists the required fixings for domestic decking.

Hardwood and Cypress decking shall be spaced with 3 mm gaps. Softwood decking shall have 5 mm gaps.

Butt joints shall be staggered (i.e. not on adjoining boards).

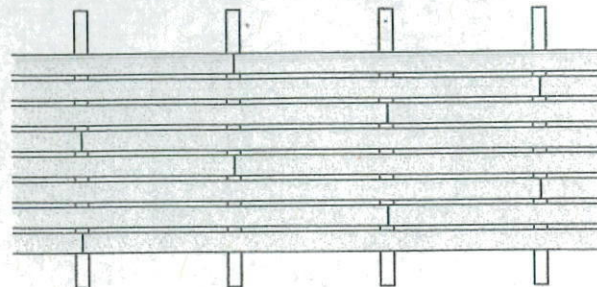

Joints staggered

A slight back-cut will assist in obtaining a tight fit at butt ends.

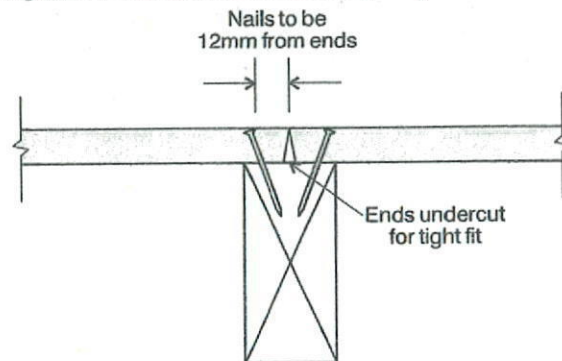

Each board shall be fixed at every joist crossing with two nails as required by Table 5. Alternatively, proprietary fixings may be used in accordance with manufacturer's instructions.

Nails shall be hot dipped galvanised or stainless steel (not zinc plated). Within 1 metre of swimming pools, stainless steel or silicon bronze fixings are recommended.

Nails shall be kept 12 mm from edges and ends of boards. Nail holes at butt joints shall be predrilled (80% nail diameter) to avoid splitting.

Nails shall be driven flush with surface (not punched).

At intermediate fixings nails shall either be offset or driven at slightly opposing angles.

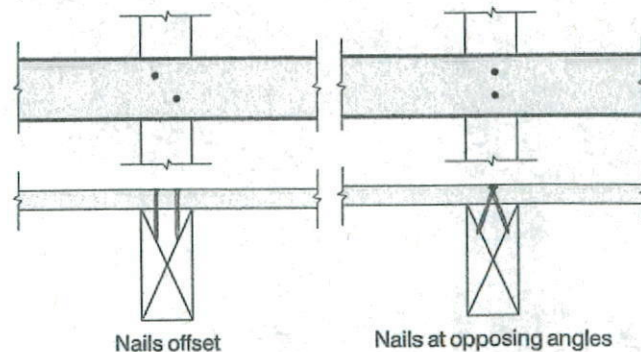

Nails offset

Nails at opposing angles

Table 5 Decking (450 mm Joist Spacing)

SPECIES	Joist Species	NAILING REQUIREMENTS (2 per fixing)
		Hand Driven
Cypress	Hardwood / Cypress*	50 x 2.8 mm Bullet Head
	Treated Pine	50 x 2.8 mm Bullet Head (deformed ring shank) or 65 x 2.8 mm Bullet Head (plain shank)
Seasoned Treated Pine	Hardwood / Cypress*	50 x 2.8 mm Flat Head
	Treated Pine	50 x 2.8 mm Flat Head (deformed ring shank) or 65 x 2.8 mm Flat Head (plain shank)
Hardwood	Hardwood / Cypress*	50 x 2.8 mm Bullet Head
	Treated Pine	50 x 2.8 mm Bullet Head (deformed ring shank) or 65 x 2.8 mm Bullet Head (plain shank)

Note: * Cypress containing sapwood should not be used closer than 250 mm from ground. Refer recommendations in AS 1810.

Recent comparative laboratory withdrawal tests carried out by Timber Qld on a wide range of commercially available machine driven nails indicated a large variation in machine nail withdrawal resistance. Installers of decking should ensure that machine nails used have equal or better withdrawal resistance than the hand nails given above. Installers should obtain comparative withdrawal information from nail suppliers or conduct comparative trials (pinch bar) on test material before using a particular machine nail.

Handrails and Balustrades

Decks more than one metre above ground require a handrail or balustrade. Refer to TDS 23 for Timber Handrails and Balustrades.

Finishing

All decks shall have a finish applied as protection against the weathering effects of sun and rain.

Note: Unprotected timber exposed to the weather will fade to a silver-grey colour and could distort and develop splitting and surface checking.

One coat of a water repellent preservative or an oil based primer plus one coat of the selected finish shall be applied to the top surface of joists and to all surfaces of decking (including cut ends) prior to fixing. Additional coats shall be applied (to manufacturer's instructions) to the top surface of decking after construction.

The following finish types are available:

Clear Finishes/Water Repellent Preservatives (WRP)

These are generally water repellent materials (waxes, resins, etc.) in a light organic solvent base. They often also contain chemicals which inhibit decay. These finishes provide protection against moisture and are recommended as a priming coat for other coatings. The compatibility of WRP with other coatings should however be checked. Generally, two weeks is required between application of WRP and other finishes.

Clear finishes provide minimal protection against the UV effects from the sun. When used on their own they require reapplication at about six monthly intervals.

Note: Clear polyurethane finishes can breakdown under UV exposure and are not recommended for external use.

Paints

Opaque paint finishes provide the best protection against weathering, however they obscure the natural colour and grain of the timber. Pale colours are recommended. Normal paints cannot withstand the wear from foot traffic, therefore only special decking paints should be used, strictly in accordance with manufacturer's recommendations.

Note: Oil-based primers are recommended for both oil-based and water-based paint finishes.

Recoating is necessary every five to seven years, depending upon exposure. Additional preparation (sanding, repriming etc.) is frequently necessary.

Decking Oils/Decking Stains

Decking oils and stains are available which provide a relatively natural, semi-transparent, protective finish. Solvent (Oil) or water based stains are available often with mould inhibiting additives. Decking stains with light coloured pigments are recommended as they absorb less heat and only slightly change the natural colour of the timber.

Reapplication is generally necessary every two to five years depending upon the amount of pigment included, and the degree of exposure. Apart from cleaning, no additional surface preparation is generally required.

Maintenance

Frequent wetting of decks should be avoided (sweep or clean, don't hose). Adequate ventilation should be provided to allow rapid drying after rain or watering. Pot plants should be on trays and prevented from overflowing. Shrubs which permanently shade the deck and creepers on rails etc. should be avoided.

Reapplication of finishes will be required at regular intervals, depending on finish type and degree of exposure. Before recoating all decks shall be thoroughly cleaned and debris removed from between boards. For some finishes, decks may also require sanding. Recoating shall be carried out in accordance with the manufacturer's recommendations.

Safe Working

Working with timber produces dust particles. Protection of the eyes, nose and mouth when sanding, sawing and planing is highly recommended. Refer to tool manufacturers for safe working recommendations for particular items of equipment.

Disposal of Offcuts and Waste

For any treated timber, do not burn offcuts or sawdust. Preservative treated offcuts and sawdust should be disposed of by approved local authority methods.



**TIMBER
QUEENSLAND**

Timber Queensland Limited

ACN 092 686 756 • ABN 50 092 686 756
500 Brunswick Street, Fortitude Valley
Brisbane Queensland 4006
PO Box 2014, Fortitude Valley BC Qld 4006

Phone: (07) 3254 1989

Fax: (07) 3254 1964

Website: www.timberqueensland.com.au

Email: admin@timberqueensland.com.au

Whilst every effort is made to ensure the accuracy of advice given, Timber Queensland Limited cannot accept liability for loss or damage arising from the use of the information supplied.