

A photograph of a grey squirrel climbing a tree trunk. The squirrel is positioned vertically, facing upwards, with its front paws reaching up and its hind legs gripping the bark. The tree bark is rough and textured. The background is a solid light blue color.

Travers

bushfire & ecology

Tree Assessment

Proposed 9 Hole Golf Course
and Cemetery
Lot 2 DP 1108408
Lot 512 DP 1079728
13 Park Road, Wallacia

December 2019
REF: (18CMCT02T)



Tree Assessment Report

Proposed Cemetery and Golf Course Redevelopment Lot 2 DP 1108408 Lot 512 DP 1079728 13 Park Road, Wallacia

Report authors: Robert Sansom B. Sc. (Hons.) - Botanist
Plans prepared: Sandy Cardow B. Sc. – GIS Technician
Approved by: Michael Sheather-Reid - B. Nat. Res. (Hons.) Managing Director
Date: 09 December 2019
File: 18CMCT02T

This document is copyright ©

Disclaimer:

This report has been prepared to provide advice to the client on matters pertaining to the particular and specific development proposal as advised by the client and / or their authorised representatives. This report can be used by the client only for its intended purpose and for that purpose only. Should any other use of the advice be made by any person including the client then this firm advises that the advice should not be relied upon. The report and its attachments should be read as a whole and no individual part of the report or its attachments should be interpreted without reference to the entire report.

The mapping is indicative of available space and location of features which may prove critical in assessing the viability of the proposed works. Mapping has been produced on a map base with an inherent level of inaccuracy, the location of all mapped features are to be confirmed by a registered surveyor.

ABN 85 624 419 870
PO Box 7138
Kariong NSW 2250

38A The Avenue
Mt Penang Parklands
Central Coast Highway
Kariong NSW 2250

t: 02 4340 5331
e: ecology@traversenvironmental.com.au
www.traversecology.com.au

Executive Summary

This tree assessment report has been prepared by *Travers bushfire & ecology* for a proposed memorial garden and reconfigured golf course within Lot 2 DP 1108408, Lot 512 DP 1079728 at 13 Park Road, Wallacia, within the Penrith local government area (LGA). Its purpose is to:-

- assess the condition and significance of trees
- Identify trees to be retained and removed

The proposed memorial gardens is located on the eastern portion of the site and a reconfigured 9 hole golf course on the eastern portions and will henceforth be referred to as the 'subject site'.

A safe useful life expectancy (SULE) assessment was conducted between 27 September and 12 October 2017. Due to likely impacts on further trees due to the reconfigured fairways, additional trees were assessed on 29 – 30 September 2019. This tree assessment report has been prepared in accordance with Australian Standard *AS4970 (2009) – Amendment No. 1 2010*.

Impact of the proposal on trees

It was estimated that approximately one thousand eight hundred (1,800) trees with a 10cm diameter at breast height (DBH) were present within the site. An assessment of all trees equal or greater than 10cm DBH and located only within or in proximity to the proposed works was undertaken. A total of 1,215 trees were assessed within the proposal footprint and immediate surrounds within the site.

It is noted that the SULE assessment identifies that the majority of the trees observed are in fair to good condition. Seven hundred and eighty-two (782) of the 1,215 assessed trees (64.36%) had a SULE condition rating of 1 or 2. This indicates that the overall health of the trees onsite is moderate to good.

The proposal will require the removal of 465 trees within or immediately adjacent to the development footprint regardless of their SULE rating. The breakdown is as follows based on an estimated one thousand eight hundred (1,800) trees with a DBH of 10cm or greater present within the site:

- Remove trees within or immediately adjacent to the development footprint (Earthworks, Development, Drainage, Golf course and Constructed wetland) - 237/1800 trees = 13.17%
- Remove trees with a low health or unsafe SULE rating (some 3b, 3c and all 4a-4f) – 212/1800 trees = 11.78%,
- Remove trees that are invasive exotic species – 16/1800 = 0.89%
- Retain all other trees wherever possible – 750 assessed trees + estimated 585 trees not assessed = 1,335/1,800 = 74.16%

Based on the above approach, the proposal and additional removal of low health, unsafe/dangerous trees or weed species results in the removal of 465 trees or 25.83% of the 1,800 trees estimated to occur within the subject site.

Tree protection zones (TPZ) are to be implemented for any retained tree within or in proximity to the proposed works in accordance with Australian Standard *AS4970 (Section 4)*. This report defines the Structural Root Zone (SRZ), Tree Protection Zone (TPZ) and other

protection measures required for trees to be retained also in accordance with Australian Standard AS4970.

Significant trees

Some of the endemic native trees present within the golf course are consistent with either the critically endangered ecological community (CEEC) Cumberland Plains Woodland (CPW) or with the Endangered Ecological Community (EEC) River-flat Eucalypt Forest on Coastal Floodplains. These threatened ecological communities are confirmed from vegetation mapping of the subject site within the *Native Vegetation Maps of the Cumberland Plain, Western Sydney* (NPWS 2002).

Ninety-four (94) trees within the subject site are visually prominent trees primarily due to their size and being 'larger than most' of the trees observed in one or more parameters such as DBH, spread or height. However, given that many other trees throughout the wider locality are comparable in size, the removal of thirty-three (33) of the ninety-four (94) visually significant trees due to their location within the development footprint (19 trees) or weed species (1 tree) is not likely to be significant. A further thirteen (13) visually significant trees are nominated for removal due to being of dangerously poor health such that they pose a risk to life or property. A total of thirty-eight (38) or 35.11% of the visually significant trees will be removed while sixty-one (61) or 64.81% of visually significant trees will be retained.

Twenty-two (22) trees were found to contain a variety of small cracks, splits or hollows. Surveys and opportunistic observations have identified that some of these hollows are occupied by native fauna such as microchiropteran bats, and other hollows are suitable for birds such as Rainbow Lorikeets. Nine (9) of the 22 assessed hollow bearing trees (38.09%) are to be removed due to proposed works (3) or poor health / safety reasons (5). Thirteen (13) or 61.90% of all assessed hollow bearing trees will be retained.

If any hollow-bearing tree is identified for removal, it will require pre-felling survey and supervision during felling by a suitably accredited fauna ecologist to effectively recover any residing fauna, particularly threatened species if present. Felling of hollow-bearing trees must follow best practice guidelines to ensure the best ethical treatment of resident fauna.

The Penrith City Council LEP (2010) Register of Significant Trees does not list any trees of conservation significance within the suburb of Wallacia or along Park Road. Trees may however be included in a tree significance register if the specimen displays cultural, historic, scientific and/ or aesthetic value. No trees present on site are considered appropriate for nomination to this register.

List of abbreviations

AS 4970	Protection of trees on a development site
APZ	asset protection zone
BPA	bushfire protection assessment
CEEC	Critically Endangered Ecological Community
CPW	Cumberland Plain Woodland
CRZ	critical root zone
DCP	Development Control Plan
DOEE	Commonwealth Department of Environment & Energy
DPIE	NSW Department of Planning, Industry and Environment
EEC	endangered ecological community
EPA	Environment Protection Agency
<i>EP&A Act</i>	<i>Environmental Planning and Assessment Act</i>
<i>EPBC Act</i>	<i>Environment Protection and Biodiversity Conservation Act</i>
ESMP	ecological site management plan
FF	flora and fauna assessment
FM Act	<i>Fisheries Management Act</i>
FMP	fuel management plan
ha	hectares
HTA	habitat tree assessment
IPA	inner protection area
LEP	local environment plan
LGA	local government area
m	metres
NES	national environmental significance
NPWS	NSW National Parks and Wildlife Service
NSW DPI	NSW Department of Industry and Investment
OEH	Office of Environment and Heritage (Part of the NSW Department of Premier and Cabinet)
OPA	outer protection area
PBP	<i>Planning for bush fire protection 2006</i>
<i>RF Act</i>	<i>Rural Fires Act</i>
RFEF	River Flat Eucalypt Forest
RFS	NSW Rural Fire Service
ROTAP	rare or threatened Australian plants
SEPP 44	<i>State Environmental Protection Policy No 44 – Koala Habitat Protection</i>
SRZ	structural root zone
SULE	safe useful life expectancy
TPO	tree preservation order
TPZ	tree protection zone
TRRP	tree retention and removal plan
<i>TSC Act</i>	<i>Threatened Species Conservation Act</i>

Table of Contents

SECTION 1.0 – BACKGROUND	1
SECTION 2.0 – SURVEY METHODS	4
2.1 Tree survey and condition assessment.....	4
2.2 Identification of tree species.....	4
2.3 Structural faults and decay.....	5
SECTION 3.0 – SURVEY RESULTS.....	6
3.1 Endangered ecological communities (EECs)	6
3.2 Council’s significant tree register.....	6
3.3 Visually prominent trees.....	6
3.4 Hollow bearing trees	6
3.5 SULE rating	7
SECTION 4.0 – TREE REMOVAL & IMPACT	9
4.1 Removal of trees due to proposal	9
4.2 Removal of trees due to condition.....	9
4.3 Impact assessment.....	9
SECTION 5.0 – TREE PROTECTION GUIDELINES	11
5.1 Tree protection measures	11
5.2 Tree protection fencing	16
SECTION 6.0 – CONCLUSIONS & RECOMMENDATIONS .	17
6.1 Conclusions	17
6.2 Recommended tree protection strategies.....	17

Attached Schedules

Schedule 1 – Tree Assessment Data Table

Schedule 2 – SULE Assessment and retention / removal plans (x8)

Schedule 3 – SULE Ratings & Terminology



Background

1

This tree assessment report has been prepared by *Travers bushfire & ecology* for a proposed memorial garden and reconfigured golf course within Lot 2 DP 1108408, Lot 512 DP 1079728 at 13 Park Road, Wallacia, within the Penrith local government area (LGA).

The proposed memorial gardens is located on the eastern portion of the site and a reconfigured 9 hole golf course on the eastern portions and will henceforth be referred to as the 'subject site'.

A safe useful life expectancy (SULE) assessment was conducted between 27 September and 12 October 2017. Due to likely impacts on further trees due to the reconfigured fairways, additional trees were assessed on 29 – 30 September 2019. This tree assessment report has been prepared in accordance with Australian Standard *AS4970 (2009) – Amendment No. 1 2010*.

This assessment is based on the SULE classification (Barrell, 1993). The purpose of this information shall be used to document trees to be retained or removed for development approval compliance and to identify the ecological, historical and visual significance of trees to be removed and/or retained as part of the future development of the site. Those trees to be retained within the development should also be of sufficient condition and form to minimise the risk of tree damage to property or persons.

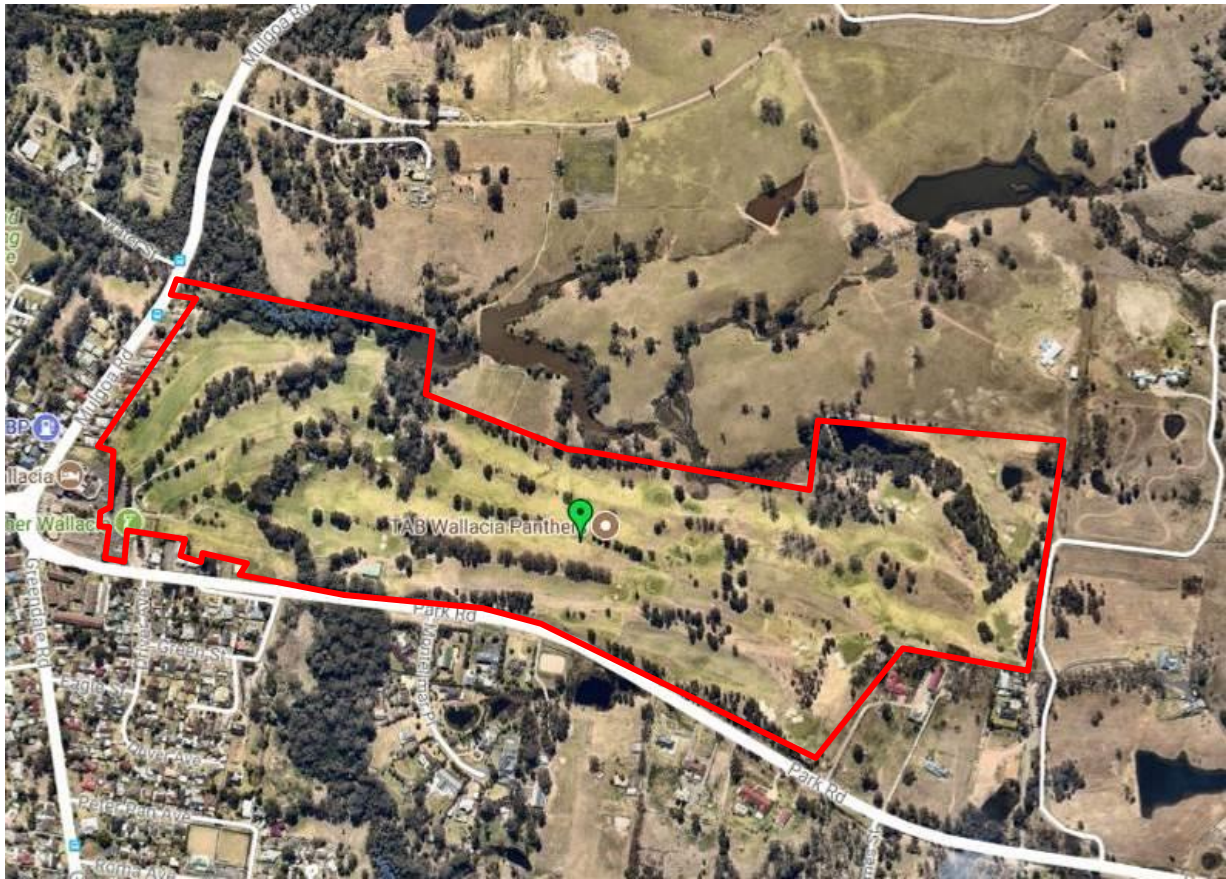

Figure 1 – Subject site



Figure 2 – Proposed golf course plan

N

 SCALE 1:1500

LEGEND

- PROPERTY BOUNDARY
- HOLE CONTOURLINE
- SCOTTING CONTOUR
- DESIGN CONTOUR - METRE
- DESIGN CONTOUR - HALF
- SCOTTING FEATURES
- PROPOSED GOLF FEATURES
- SCOPE OF BULK BARTHANORGE
- DRAINAGE LINE (150mm PVC)
- DRAINAGE LINE (150mm PVC)
- DRAINAGE LINE (150mm AD)
- INTERMARKER PIT
- CART PATH (SCOTTING)
- DISCONTINUED DRAINAGE
- CART PATH (GWS)
- TANKER BOARDWALK BRIDGE
- PROPOSED BLANKET
- PROPOSED GRASS
- PROPOSED TURF (TBC)
- PROPOSED TURF (Cypress spp. 'Stella Aris')
- PROPOSED FAIRWAY (Cypress spp. 'Carolinensis')
- PROPOSED BUNKER BOUNDARY (Cypress spp. 'Carolinensis')
- CREEK / WETLAND SCOTTING
- CREEK / WETLAND PROPOSED

WALLACIA
 CONSULTANTS

CLIENT
CATHOLIC METROPOLITAN CEMETERIES TRUST

PROJECT
WALLACIA COUNTRY CLUB

DRAWING NO.
 W917-DA-02

ISSUE
 C

SHEET NO.
 2 / 12

SCALE
 1:1500 (A1)

DATE
 11.11.2019

GOLF COURSE GENERAL LAYOUT PLAN

REV	DESCRIPTION	DATE
A	ISSUE FOR REVIEW	22.09.19
B	ISSUE FOR REVIEW	31.10.19
C	ISSUE FOR APPROVAL	11.11.19



Figure 3 – Proposed cemetery layout



Survey Methods

2

2.1 Tree survey and condition assessment

Tree survey and assessment of the study area was conducted between 27 September and 12 October, 2017. After changes to the proposal, further tree survey was undertaken on 29-30 October 2019. Tree inspections and assessment were undertaken in accordance with Australian Standard *AS4970 (2009)-Amendment 1 (2010)*.

The aim of this tree assessment is to assess the condition and significance of one-thousand two-hundred and fifteen (1,215) trees within or immediately adjacent to the development footprint as well as determine tree locations according to proposed building envelopes, earthworks and services.

The following survey and assessment was undertaken:

- an inspection of the site and relevant native and planted exotic trees
- aerial photographic interpretation of the study area
- a health assessment (SULE rating) of the trees
- an assessment of the significance of individual trees
- compilation of this report detailing the results of the above assessments.

Trees with diameter at breast height (DBH) greater than 10cm were assessed. The tree assessment data is provided within Schedule 1, the location and number of each tree is shown in Schedule 2 and a description of terminology used is provided as Schedule 3.

The management requirements for maintaining safe trees (pruning, thinning etc.) was also considered in determining the health rating, therefore health ratings given to trees within this report assumes that appropriate maintenance will be provided by a qualified arborist during the life of the assessed trees. Incorrect or absent tree maintenance can significantly accelerate tree decline and increase hazard potential.

2.2 Identification of tree species

The identification of tree species is undertaken using available field guides and botanical texts. For any unidentifiable species a qualified and experienced botanist is utilised to confirm the tree identification. In some cases exotic species were identified to family name only. Samples may be sent to the Royal Botanic Gardens for a positive identification should a potential threatened or rare species be present and where the field identification is not clear. Further samples may be required during flowering and fruiting seasons of the tree to confirm the identification.

2.3 Structural faults and decay

Visible evidence of structural defects and evidence of decay is briefly assessed during tree inspections. Structural defects are categorised into (Matheny & Clark 1994):

- root defects – including but not limited to suspect root rot, root exposure, root pruning or restriction
- trunk defects – including but not limited to evidence of decay, structural damage, *Phytophthora* and bracket fungi, excessive lean, exposed wood, borer damage, hollows, cracks, deadwood and multiple attachments
- crown defects - including but not limited to poor taper, bow or sweep, forks, multiple attachments, excessive end weight, cracks, splits, hangers, girdling, wounds, decay, cavities, conks, mushroom or bracket fungi, bleeding/sap flow, hollows, deadwood, borers, termites, ants, cankers, balls, burls and previous failures

Visible evidence of structural defects or decay are noted during inspections however we advise that the individual trees require detailed assessment if they are located or are to be retained in close proximity to buildings or proposed works.

Overall tree health is an indicator of the life of the tree but sometimes hidden structural defects or decay can cause immediate structural failure when a tree is subjected to mechanical stress or forces due to high winds or other natural impacts.

Structural defects or decay are not always visible from the exterior and may only become evident after damage has been caused. In the event that structural faults are detected, such as caused by hollows, fungal or termite attack, then internal diagnostic testing of the trees structural integrity is recommended.

Internal Diagnostic Testing (IDT) can be undertaken by Resistograph® to determine the trees structural integrity by measuring the location, extent and positioning of internal decay at the defects detected.

Travers bushfire & ecology advises that an a qualified specialist arborists advice should be sought for any trees in close proximity to any proposed works or if a structural assessment is required to determine the extent of structural faults and decay for tree retention or removal purposes.



Survey results

3

A total of one thousand two hundred and fifteen (1,215) trees with a DBH greater than 10cm were assessed within the subject site (see Schedule 1). Trees were numbered T0001, T0002, T0003, etc., through to T1215 and a metal tag embossed with the tree number was placed on the trunk for re-identification during future works. Tree tags were attached generally at a height of approximately 2 metres. Tree tag number 245 was not used, there is also a double-up with tags T1194 and T1194A, therefore the number of trees assessed (1,215) has tags going to 1,215.

3.1 Endangered ecological communities (EECs)

Some of the endemic native trees present within the golf course are consistent with either the critically endangered ecological community (CEEC) Cumberland Plain Woodland (CPW) or with the Endangered Ecological Community (EEC) River-flat Eucalypt Forest on Coastal Floodplains (RFEF). These threatened ecological communities are confirmed from ground-truthing during the Flora and Fauna survey and assessment (2017 and 2019) as well as from vegetation mapping of the subject site within the *Native Vegetation Maps of the Cumberland Plain, Western Sydney* (NPWS 2002).

3.2 Council's significant tree register

The Penrith City Council LEP (2010) Register of Significant Trees does not list any trees of conservation significance within the suburb of Wallacia or along Park Road. Trees may however be included into a tree significance register if the specimen displays cultural, historic, scientific and/or aesthetic value. No trees present on site are considered appropriate for nomination to the significant tree register.

3.3 Visually prominent trees

Ninety-four (94) trees within the subject site are visually prominent trees primarily due to their size and being 'larger than most' of the trees observed in one or more parameters such as DBH, spread or height. However, given that many other trees throughout the wider locality are comparable in size, the removal of thirty-three (33) of the ninety-four (94) visually significant trees due to their location within the development footprint (19 trees) or weed species (1 tree) is not likely to be significant. A further thirteen (13) visually significant trees are nominated for removal due to being of dangerously poor health such that they pose a risk to life or property. A total of thirty-eight (38) or 35.11% of the visually significant trees will be removed while sixty-one (61) or 64.81% of visually significant trees will be retained.

3.4 Hollow bearing trees

Twenty-one (21) trees were found to contain a variety of small cracks, splits or hollows. Surveys and opportunistic observations have identified that some of these hollows are occupied by native fauna such as microchiropteran bats, and other hollows are suitable for

birds such as Rainbow Lorikeets. Eight (8) of the 21 assessed hollow bearing trees (38.09%) are to be removed due to proposed works (3) or poor health / safety reasons (5). Thirteen (13) or 61.90% of all assessed hollow bearing trees will be retained.

If any hollow-bearing tree is identified for removal, it may require fauna survey prior to felling and will require supervision by a suitably accredited fauna ecologist at the time of felling to effectively recover any residing fauna, particularly threatened species if present. Felling of hollow-bearing trees must follow best practice guidelines to ensure the best ethical treatment of resident fauna.

3.5 SULE rating

An assessment of the attributes and health of each assessed tree is contained in Schedule 1. Where trees have been downgraded with respect to health, a comment as to the reasons for the downgrade is generally provided.

A summary of SULE results is provided in the following table:

Table 1 – Summary of SULE ratings

SULE rating	No. of trees assessed	Proportion of trees assessed
1a	2	0.16%
1b	0	0.00%
1c	1	0.08%
2a	713	58.68%
2b	3	0.25%
2c	48	3.95%
2d	15	1.23%
3a	62	5.10%
3b	43	3.54%
3c	129	10.62%
3d	6	0.49%
4a	121	9.96%
4b	0	0.00%
4c	67	5.51%
4d	5	0.41%
4e	0	0.00%
4f	0	0.00%
TOTAL	1,215	100%

Generally, the trees on site were found to be in a moderate to good condition. Seven hundred and eighty-two (782) of the 1,215 assessed trees (64.36%) had a SULE condition rating of 1 or 2. This indicates that the overall health of the trees onsite is moderate to good.

Some areas within the subject site contain trees that are crowded and/or suppressed, mostly due to regrowth of younger, smaller specimens underneath established larger trees, or in areas that have been densely planted. This has resulted in a number of the trees being given a reduced SULE rating. This crowding and suppression can result in narrowing, tilting, off-centre canopies, canopy dieback and poor structural growth due to competition for available resources. However, it is considered that the level of suppression within the subject site is not high and that if natural processes cause a larger tree to die, the smaller trees underneath will rapidly fill the vacant space.

Various other defects related to poor health were observed for different trees and generally, where a tree's health has been downgraded the reasons are provided in the comments column in Schedule 1.

Trees of lower health or vigour are mostly given a SULE rating of 3b as they tend to present safety or nuisance problems and often have a moderate to large amount of deadwood which indicates a decline in health and potential safety concerns now or in the near future, despite the potential for them to remain alive for up to fifteen (15) years or more.

Trees of a suppressed nature with limited or minor defects are likely to be retainable. However, those that are heavily suppressed or have some defect due to over-competition have largely been rated at a lower SULE rating. Trees with a tolerable amount of suppression have generally been given a moderate SULE rating and can often be retained with a further assessment carried out within two to five (2-5) years to assess whether their condition has deteriorated or improved.



Tree Removal & Impacts

4

4.1 Removal of trees due to proposal

The proposal is for the western half of the site to be a revised 9-hole golf course, while the eastern parts of the site is for a proposed cemetery which includes buildings, internal roads and services. These areas are situated within a large area (approximately 44ha) of existing golf course. It was estimated that there were 1,800 trees within the subject site. A total of 1,215 trees were assessed for a SULE rating because they were within or immediately adjacent to the proposal footprint. Two-hundred and thirty-seven (237) trees or 13.16% of the 1,800 trees estimated to occur within the subject site are proposed for removal, regardless of their SULE rating, as they are located within or immediately adjacent the development footprint, drainage, golf course, wetland or associated earthworks.

4.2 Removal of trees due to condition

In assessing the removal of trees for a proposal, trees assessed with a SULE rating of 3b, 3d or 4a – 4f are generally recommended for removal based on a short life expectancy, are dangerous or in a very poor condition. This is particularly in the case of trees in close proximity to adjoining buildings or areas where the public has access.

The following table is a summary of trees proposed for removal and retention:

Table 4.1 – Trees to be removed and retained

Trees removed within the development footprint	237	13.17% of estimated 1800 trees
Removal of trees with a poor SULE ratings that have safety or nuisance concerns – SULE 4a to 4f and some others rated 3b or 3d	212	11.78% of estimated 1800 trees
Trees removed for being invasive weeds	16	0.89% of estimated 1800 trees
Trees retained (750 assessed trees PLUS 585 estimated trees not assessed)	1,335	74.17% of estimated 1800 trees
Total	1,800	100%

4.3 Impact assessment

In determining which trees are to be removed, *Travers bushfire and ecology* recommend trees for removal in the following order:

- Remove trees within or in close proximity to development footprints (regardless of SULE rating) - 237/1800 trees = 13.17%
- Remove trees with an Unsafe or Dangerous SULE rating (some 3b and 3c, and all 4a-f) – 212/1800 trees – 11.78%,

- Remove trees that are invasive exotic species – $16/1800 = 0.89\%$
- Retain all other trees wherever possible – $1,335/1800 = 74.17\%$

Based on the above approach, the proposal, removal of unsafe or dangerous trees, and the removal of invasive exotic species results in the removal of 465 trees or 25.83% of the 1,800 trees estimated to occur within the subject site.

The Penrith City Council LEP (2010) Register of Significant Trees does not list any trees of conservation significance within the suburb of Wallacia or along Park Road. Trees may however be included into a tree significance register if the specimen displays cultural, historic, scientific and/or aesthetic value. No trees present on site are considered appropriate for nomination to the significant tree register.

For all trees that are to be retained, it is recommended that Tree Protection Zones (TPZ) are to be implemented for any retained tree in accordance with Australian Standard *AS4970* (section 5.1).

If 10% or less of the TPZ for any tree is impacted by development, then these trees shall have the TPZ expanded to 1.1 times the calculated TPZ as compensation. This fulfils the requirement for the compensatory expansion of the TPZ as required in *AS4970-2009-Amendment 1-2010*. These trees can therefore be retained in situ with no significant impact expected. No trees within the subject site are impacted in such a manner, therefore compensatory TPZs are not required.



Tree Protection Guidelines

5

The following sections provide guidance as to the expected TPZs required for trees to be retained within the development site (either in the staged or ultimate development scenario), or affected by associated works. TPZs consist of:

- (a) Tree protection zone (TPZ) which aims to protect the full extent of the tree, and
- (b) Structural root zone (SRZ) which aims to define the critical root zone (CRZ) for the tree without causing fatal damage to the tree.

These are generic guidelines and any tree specific advice and management is required to assess impacts on trees that are affecting more than 10% of the tree protection zone or have suspected structural damage.

5.1 Tree protection measures

To determine the SRZ, the following is applied in accordance with Australian Standard *AS4970 – 2009 – Amendment 1-2010*.

The tree protection zone (TPZ) radius is measured by the DBH x 12 (Australian Standard *AS4970 – 2009*). For instance, if a tree has a DBH of 50cm, the TPZ radius would be 6m and a tree of DBH 30cm would have a TPZ radius of 3.6m.

The structural root zone (SRZ) is the area which is required to maintain a tree's stability. The SRZ is measured as:

SRZ radius = $(BD \times 50)^{0.42} \times 0.64$ where BD is the basal trunk diameter, in m, measured above the root buttress. If BD is 50cm, then the SRZ would be 2.47m.

During the survey, DBH was measured for each tree to allow for TPZ to be calculated should the tree be retained as part of the future landscaping.

Table 2 – Estimated TPZ radius for trees

DBH (cm)	TPZ radius (m)
15	1.8
	2.0 metres is specified as the minimum within AS 4970
20	2.4
25	3
30	3.6
35	4.2
40	4.8
45	5.4
50	6
55	6.6

Table 2 – Estimated TPZ radius for trees

DBH (cm)	TPZ radius (m)
60	7.2
65	7.8
70	8.4
75	9
80	9.6
85	10.2
90	10.8
95	11.4
100	12
105	12.6
110	13.2
115	13.8
120	14.4
150	18
200	24
250	30

Table 3 – Estimated SRZ radius for trees

BD (cm)	SRZ radius (m)
15	1.49 2.0 metres is specified as the minimum within AS 4970
20	1.68 2.0 metres is specified as the minimum within AS 4970
25	1.85 2.0 metres is specified as the minimum within AS 4970
30	2
35	2.13
40	2.25
45	2.37
50	2.47
55	2.57
60	2.67
65	2.76
70	2.85
75	2.93
80	3.01
85	3.09
90	3.17
95	3.24
100	3.31
105	3.38
110	3.44
115	3.51
120	3.57
150	3.92
200	4.43
250	4.86
300	5.25

The SRZ and TPZ radii calculated for each of the trees assessed within the subject site are provided in Schedule 1.

When working in close proximity of any tree to be retained or the nominated TPZ located within or adjacent to potential development areas, the following general management principles should be adopted:

- earthworks around subject trees are to be undertaken in the presence of a qualified ecologist / arborist who may provide additional on-site advice
- machine digging within the root mass of the subject tree (or trees) is to be minimised and, where possible, replaced by hand digging
- any exposed roots of the subject tree should be wrapped and protected during exposure and be replaced in a similar position prior to disturbance
- inspection of retained trees by a qualified person should be conducted post development completion for safety compliance.

Any retained tree on site will require protection both during and after development construction, applying the following tree protection guidelines:

The following guidelines are proposed in relation to any trees that may be retained within or adjacent to the proposed works area:

- Installation of a TPZ will be required surrounding any retained tree or group of trees. This TPZ can generally be provided by preserving an area equivalent to that shown in Schedule 1. A SRZ will apply to all retained trees in close proximity to work areas. No more than 10% of the TPZ should be impacted by earthworks with no infiltration into the SRZ. The TPZ is to be compensated elsewhere on the impacted tree to compensate for the loss of small areas of the TPZ. This is achieved by increasing the TPZ to an equivalent area to the area of impacted TPZ (Figure 4).

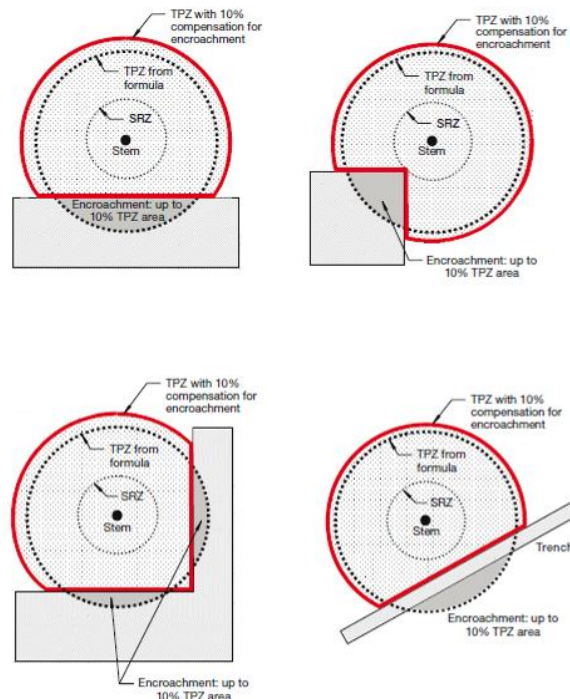

NOTE: Less than 10% TPZ area and outside SRZ. Any loss of TPZ compensated for elsewhere.

Figure 4 - Minor encroachment on TPZ and 10% compensation for encroachment
(Source AS 4970-2009)

- ii. Trees to be retained, and in close proximity to any works, are to be protected by temporary fencing. Such temporary fencing can be constructed from plastic mesh, post and wire or temporary chain link fence panels. All fence posts and supports are to be located clear of the roots and have sufficient strength to support the fence without bending or collapsing. TPZs in close proximity to proposed works are to be marked and sign-posted. The protection fencing is not to be removed or altered without the approval of an appointed arborist. TPZ fencing is to be inspected on a regular basis and maintained in good condition.
- iii. All trees nominated for removal are to be removed only after the temporary fencing of the trees to be retained has been completed and prior to any construction activity or bulk earthworks. Approved tree removal operations in the vicinity of retained trees are to be undertaken in a manner that avoids canopy or root damage and/or soil compaction to any TPZ associated with any retained tree. Such works should be supervised by a qualified arborist.
- iv. Stumps are to be ground not dozed or dug out unless they impact on the installation of services, roads or building works.
- v. All excavation including but not limited to trenches, footings and major earth movement are to be avoided within TPZ's.
- vi. Stockpiling materials and soils within TPZs is to be avoided.
- vii. All machinery and vehicles are to be excluded from TPZs during all operations.
- viii. Where the proposed works are likely to cause excessive dust generation, the Tree is to be protected with shade cloth on the tree protection fence to minimise dust collection on the leaves.
- ix. The following activities prohibited within the Native Bushland Reserve includes but are not limited to:
 - machine excavation (including trenching)
 - excavation for silt fencing
 - cultivation
 - Storage
 - preparation of chemicals, including cement products
 - parking of vehicles or plant
 - refuelling
 - dumping of waste
 - refuelling, wash down or cleaning of equipment
 - placement of fill
 - lighting of fires
 - soil level changes
 - temporary or permanent installation of signs
 - physical damage to trees.
- x. Any works undertaken within TPZs are to be supervised and certified (photographed and documented) by a qualified arborist.

- xi. Where advised by the arborist, trunk and branch protection (Figure 5) is to be installed to a minimum height of 2 m using materials and positioning as advised by an appointed arborist.
- xii. Where advised by the arborist, other temporary root protection measures (Figure 5) such as thick mulch (50-100mm deep) or crushed rock below rumble boards, are to be installed to prevent root damage and soil compaction within the TPZ.
- xiii. Scaffolding is to be erected outside of the TPZ, where unavoidable protection measures are to be specified by the appointed arborist.
- xiv. All services are to be routed outside of the TPZ. Where not possible the arborist will specify directional drilling (at least 600mm deep) or manual excavation to avoid impacted on the insitu roots subject to the works and potential root damage.
- xv. If pruning is required it is to be undertaken by an arborist in accordance with AS4373 to prevent structural damage, disease and poor form.

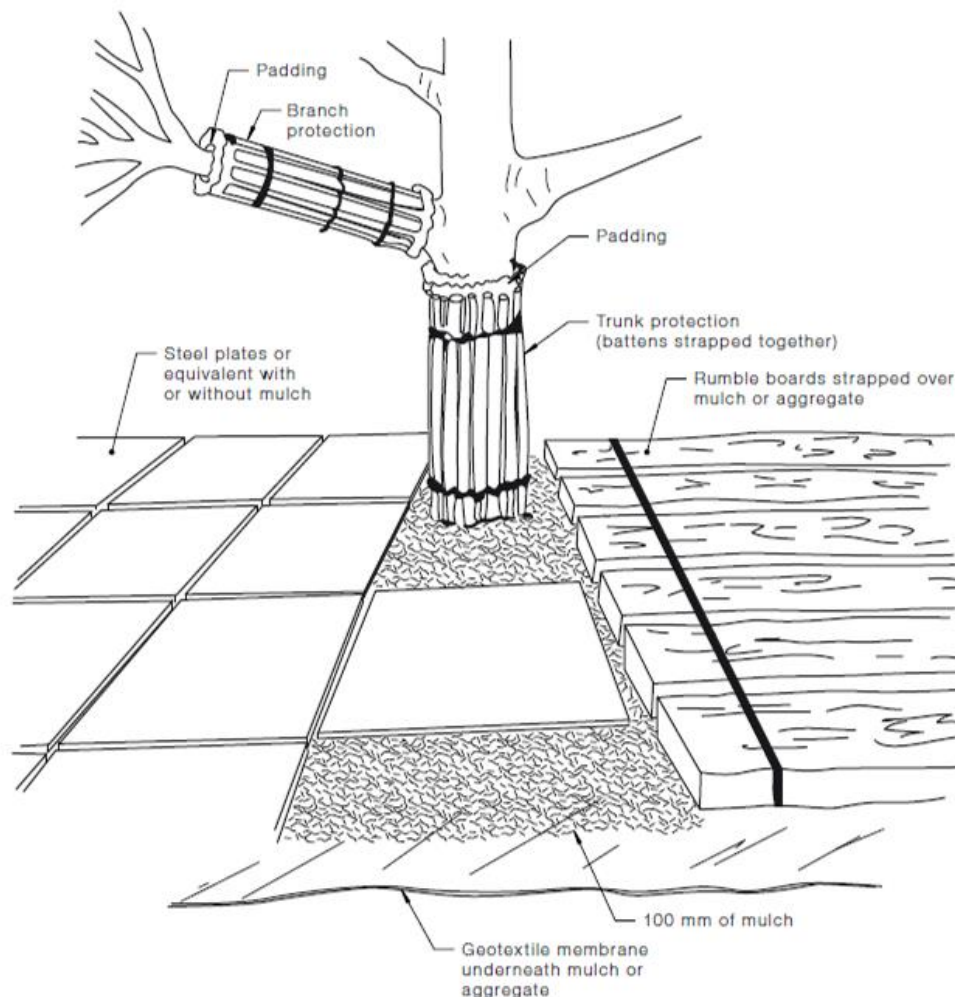

NOTES:

- 1 For trunk and branch protection use boards and padding that will prevent damage to bark. Boards are to be strapped to trees, not nailed or screwed.
- 2 Rumble boards should be of a suitable thickness to prevent soil compaction and root damage.

Figure 5 - Examples of trunk, branch and ground protection as per AS4970- 2009

5.2 Tree protection fencing

Temporary tree protection fencing should be erected before any machinery or materials are brought onto the site and before the commencement of works (including demolition and bulk earthworks). Once erected, protective fencing must not be removed or altered without approval by the project arborist. The TPZ is to be fully secured to restrict access onto the protected root zone.

AS-4687 specifies applicable fencing requirements. Construction fencing on the recommended alignment of the TPZ fencing for each tree or group of trees can be installed as part of the protective fencing.

For construction crews, signage identifying the TPZ shall be placed at 10 metre intervals along the TPZ fencing. These signs will face towards the development site and shall have lettering that complies with AS 1319. These signs will also specify the severe penalties for harming the Critically Endangered Ecological Community "*Cumberland Plain Woodland*" and "*River-flat Eucalypt Forest on Coastal Floodplains*" in any way.

TPZ fencing is to be inspected on a regular basis and maintained in good condition. Any works within the mapped tree protection zones is to be supervised (for excavation works) or under the direction of an AQ5 qualified arborist to limit damage to root zones and to install additional root, trunk and branch protection measures.



Conclusions & Recommendations

6

6.1 Conclusions

An assessment of all trees equal or greater than 10cm Diameter at Breast Height (DBH) that were located within or immediately adjacent to the proposed works footprint was undertaken. A total of 1,215 trees were assessed within or immediately adjacent to the proposed works footprint. The proposal results in the removal of 237 trees or 13.17% of the 1,800 trees estimated to occur within the subject site. A further 212 trees (11.78%) will be removed for safety or tree health reasons, and 16 trees (0.89%) will be removed as they are invasive weed species. Therefore, in total, the proposed works and the removal of unsafe, dangerous or invasive weed trees results in the removal of 465 trees or 25.83% of the 1,800 trees estimated to occur within the subject site.

It is noted that the SULE assessment identifies that seven hundred and eighty-two (782) of the 1,215 assessed trees (64.36%) had a SULE condition rating of 1 or 2. This indicates that the overall health of the trees onsite is moderate to good.

For any trees that are to be retained, it is recommended that Tree Protection Zones (TPZ) are to be implemented for any retained tree in accordance with Australian Standard *AS4970* (section 5.1). These TPZs are provided in Schedule 1 – Tree Assessment Data Table and shown within the SULE Assessment and Retention / Removal Plans within Schedule 2.

6.2 Recommended tree protection strategies

To minimise impacts in local ecology and to maintain a stand of healthy trees within a broad scale development, the following recommendations apply:

- Aim to retain hollow bearing trees of good condition wherever possible throughout the landscape in order to retain fauna habitat
- Preferentially remove dangerous or poor condition trees and examine development layouts to maximise tree retention
- Consider the placement of services to avoid or minimise tree removal
- Where appropriate, create mini reserves of good quality trees for future public or private use
- Remove suppressed or otherwise poor condition trees to reduce fuel loads
- Actively replant locally occurring native (endemic) trees within the streetscape and any open space areas to maximise local amenity within the development, to consolidate any retained threatened ecological communities such as Cumberland Plain Woodland (CPW) or River-flat Eucalypt Forest (RFEF) within the locality and to provide suitable habitat for locally occurring native fauna
- Hollows are to be harvested from felled trees and re-used for restoration of habitat at the discretion of the project ecologist as per the VMP.

In the event that trees are retained under the ultimate development proposal, appropriate tree protection measures should be implemented including:

- i. In the event that trees can be retained it is considered that an AQ5 qualified arborist be engaged to manage any construction works within or immediately adjacent to the TPZ and to identify any other mitigation measures to maintain or improve their condition where the works proposed impact on more than 10% of the TPZ
- ii. Native vegetation such as Cumberland Plains Woodland (CPW) (which includes trees, shrubs and ground layer) is listed as a Critically Endangered Ecological Community (CEEC) within the NSW *TSC Act* (1995) and also within the Commonwealth *EPBC Act* (1999). Additionally, River-flat Eucalypt Forest (RFEF) which is listed as an Endangered Ecological Community (EEC) within the NSW *TSC Act* (1995) is also present. For these threatened ecological communities to be retained in close proximity to any works it is to be protected by temporary fencing that is to be erected prior to any bulk earthworks or construction phases. Such fencing can be constructed from plastic bunting, post and wire or temporary chain link fence panels.
- iii. TPZs in close proximity to proposed works should be adequately marked and sign-posted as a "No Go Zone". Signage identifying the TPZ shall be placed at 10 metre intervals along the TPZ fencing. These signs will face towards the development site and shall have lettering that complies with *AS 1319*. These signs will also specify the severe penalties for harming the Critically Endangered Ecological Community "*Cumberland Plain Woodland*" or the Endangered Ecological Community "*River-flat Eucalypt Forest*" in any way. TPZ fencing and signage should be inspected on a regular basis and maintained in good condition.
- iv. All trees nominated for removal are to be removed prior to any construction activity or bulk earthworks. Approved tree removal operations in the vicinity of retained trees are to be undertaken in a manner that avoids canopy or root damage and soil compaction to retained trees. Such works should be supervised by a qualified arborist.
- v. Stumps are to be ground, not dozed or dug out unless they impact on the installation of services, roads or building works.
- vi. All trenches footings and major earth movement are to avoid TPZs.
- vii. Stockpiling materials and soils within TPZs is forbidden.
- viii. Machinery and other vehicles are to avoid TPZs during all operations.
- ix. Any trenching or construction works unavoidably undertaken within TPZs should be witnessed, supervised and recorded (photographed and documented) by an AQ5 qualified arborist.

Bibliography

- Barrell, J. (1993) *Pre-planning Tree Surveys: Safe Useful Life Expectancy (SULE) is the Natural Progression*. Arboricultural Journal Vol. 17, pp 33-46, AB Academic Publishers, Great Britain.
- Boland, D. J., Brooker, M. I. H., Chippendale, G. G., Hall, N., Hyland, B. P. M., Johnston, R. D., Kleinig, D. A., Turner, J. D. (1992) *Forest Trees of Australia*. CSIRO, Melbourne.
- British Standard BS5837 (1991) *Guide for Trees in Relation to Construction*, BSi Standards.
- Brooker, M. I. H. and Kleinig, D. A. (1999) *Field Guide to Eucalyptus - South-eastern Australia*. Volume 1, Second Edition, Bloomings Books.
- Florence, R. G. (1996) *Ecology and Silviculture of Eucalypt Forests*. CSIRO, Collingwood Victoria.
- Hadlington, P. W. and Johnston, J. A. (1977) *Australian Trees, a Guide to Their Care and Cure*. Printed in Hong Kong by South China Printing Company.
- Harden, G. (1993) *Flora of New South Wales* University NSW Press.
- Queensland Arboricultural Association Inc (website)
<http://www.qaa.net.au/calculations.php?>
- Mattheck, C. and Breloer, H (1998) *The Body Language of Trees - A Handbook for Failure Analysis*. HMSO, London.
- Rinn, F 2011 *Basic Aspects of Mechanical Stability of Tree Cross-Sections*, *Arborist News*, Feb 2011, pp. 52-54.
- Simpfendorfer, K. J. (1992) *An Introduction to Trees for South-eastern Australia*. Inkata Press.
- Threatened Species Conservation Act (TSC Act) (1995) *Schedules 1, 2 and 3*. NSW Scientific Committee.

Schedule 1

Tree Assessment Data Table

No 13 Park Road, Wallacia

Tag No.	Common Name	Scientific Name	DBH	BD (cm)	Height (m)	Spread (m)	Vigour (%)	SULE	TPZ Radius (m)	SRZ Radius (m)	Ret/Rem	Reason	Visual Sig	Habitat Tree	Comments
T1	Red Robin	<i>Photinia</i> sp.	31	47	7	4	85	2a	3.70	2.41	Remove	Dev			Epicormic growth, competition
T2	Chinese Elm	<i>Ulmus parvifolius</i>	33	43	8	7	85	2a	3.96	2.32	Remove	Dev			competition
T3	A Cypress	<i>Cupressus</i> sp.	35	40	7	5	80	2a	4.24	2.25	Remove	Dev			suppressed below
T4	Weeping Bottlebrush	<i>Callistemon viminalis</i>	33	40	8	5	85	2a	3.96	2.25	Retain				competition
T5	White Cedar	<i>Melia azederach</i>	34	37	10	5	85	2a	4.08	2.18	Retain				competition
T6	A Bottlebrush	<i>Callistemon</i> sp. (cultivar)	30	35	8	5	85	2a	3.62	2.13	Retain				
T7	A Cypress	<i>Cupressus</i> sp.	48	45	12	5	75	3c	5.80	2.37	Remove	Health			suppressed below, competition
T8	Radiata Pine	<i>Pinus radiata</i>	57	110	12	9	80	1a	6.84	3.44	Remove	Earthwks			kink at base
T9	A Cypress	<i>Cupressus</i> sp.	34	40	7	3	85	3c	4.08	2.25	Remove	Dev			leaning canopy, suppressed
T10	A Cypress	<i>Cupressus</i> sp.	49	45	9	5	85	2a	5.92	2.37	Remove	Dev			
T11	Photinia (cultivar)	<i>Photinia</i> sp. (cultivar)	35	35	9	6	85	2a	4.24	2.13	Remove	Dev			
T12	Photinia (cultivar)	<i>Photinia</i> sp. (cultivar)	18	30	5	3	85	2a	2.11	2.00	Remove	Dev			
T13	Photinia (cultivar)	<i>Photinia</i> sp. (cultivar)	21	25	5	3	85	2a	2.54	1.85	Remove	Dev			
T14	Photinia (cultivar)	<i>Photinia</i> sp. (cultivar)	20	29	6	3	85	3a	2.40	1.97	Remove	Dev			competition
T15	Photinia (cultivar)	<i>Photinia</i> sp. (cultivar)	21	25	6	3	86	2a	2.57	1.85	Remove	Dev			
T16	Photinia (cultivar)	<i>Photinia</i> sp. (cultivar)	34	40	7	4	86	2a	4.07	2.25	Remove	Dev			
T17	Photinia (cultivar)	<i>Photinia</i> sp. (cultivar)	26	35	7	5	85	2a	3.15	2.13	Remove	Dev			
T18	Photinia (cultivar)	<i>Photinia</i> sp. (cultivar)	26	40	5	5	85	2a	3.14	2.25	Retain				
T19	Photinia (cultivar)	<i>Photinia</i> sp. (cultivar)	26	35	5	5	85	3a	3.12	2.13	Retain				crowded, competition
T20	Photinia (cultivar)	<i>Photinia</i> sp. (cultivar)	23	25	5	5	85	3c	2.78	1.85	Retain				competition
T21	Photinia (cultivar)	<i>Photinia</i> sp. (cultivar)	21	25	4	3	80	3a	2.50	1.85	Retain				competition
T22	Photinia (cultivar)	<i>Photinia</i> sp. (cultivar)	23	28	4	3	80	3a	2.76	1.94	Retain				competition
T23	Broad-leaved Privet	<i>Ligustrum lucidum</i>	15	20	6	3	70	3c	2.00	1.68	Remove	Weed			competition, suppressed
T24	Broad-leaved Privet	<i>Ligustrum lucidum</i>	12	17	6	2	65	3c	2.00	1.57	Remove	Weed			competition, narrow canopy
T25	Broad-leaved Privet	<i>Ligustrum lucidum</i>	28	30	9	3	75	3c	3.39	2.00	Remove	Weed			competition
T26	Broad-leaved Privet	<i>Ligustrum lucidum</i>	29	38	9	4	80	3a	3.47	2.20	Remove	Weed			competition
T27	Broad-leaved Privet	<i>Ligustrum lucidum</i>	19	36	8	4	65	3c	2.31	2.15	Remove	Weed			crowded, competition
T28	Weeping Bottlebrush	<i>Callistemon viminalis</i>	58	85	13	9	75	3a	6.96	3.09	Retain				competition
T29	Broad-leaved Privet	<i>Ligustrum lucidum</i>	25	35	10	5	75	3a	3.00	2.13	Remove	Weed			competition
T30	Broad-leaved Privet	<i>Ligustrum lucidum</i>	41	55	11	5	60	3c	4.87	2.57	Remove	Weed			deadwood, competition
T31	A Bottlebrush	<i>Callistemon</i> sp. (cultivar)	40	50	9	7	80	3a	4.75	2.47	Retain				crowded
T32	Broad-leaved Privet	<i>Ligustrum lucidum</i>	39	38	12	4	60	3c	4.66	2.20	Remove	Weed			crowded
T33	Broad-leaved Privet	<i>Ligustrum lucidum</i>	29	45	10	3	65	3c	3.52	2.37	Remove	Weed			crowded
T34	Weeping Bottlebrush	<i>Callistemon viminalis</i>	37	80	8	6	85	2a	4.46	3.01	Retain				crowded, suppressed above
T35	White Cedar	<i>Melia azedarach</i>	39	70	12	5	45	4d	4.73	2.85	Remove	Health			crowded, broken trunk, suppressed
T36	Camphor Laurel	<i>Cinnamomum camphora</i>	32	40	13	6	65	3c	3.84	2.25	Remove	Weed			crowded, suppressed below
T37	A Bottlebrush	<i>Callistemon</i> sp. (cultivar)	37	85	9	5	80	2a	4.42	3.09	Retain				suppressed above
T38	Broad-leaved Privet	<i>Ligustrum lucidum</i>	21	35	7	3	70	3c	2.47	2.13	Remove	Weed			suppressed above, deadwood
T39	A Bottlebrush	<i>Callistemon</i> sp. (cultivar)	31	40	8	8	75	2a	3.73	2.25	Retain				crowded, suppressed above
T40	Weeping Bottlebrush	<i>Callistemon viminalis</i>	50	90	9	12	80	2a	6.05	3.17	Retain				competition
T41	Spotted Gum	<i>Corymbia maculata</i>	50	58	21	13	90	2a	6.00	2.63	Remove	Earthwks			
T42	Spotted Gum	<i>Corymbia maculata</i>	59	69	23	14	90	2a	7.08	2.83	Remove	Earthwks			
T43	Spotted Gum	<i>Corymbia maculata</i>	69	109	24	16	85	2c	8.28	3.43	Retain		V2		damaged cambium, deadwood
T44	Chinese Tallow	<i>Sapium sebiferum</i>	42	72	13	9	45	4a	5.04	2.88	Remove	Health			suppressed above, damaged cambium, deadwood
T45	Grey Gum	<i>Eucalyptus punctata</i>	58	70	24	16	80	3c	6.96	2.85	Remove	Earthwks			damage cambium, deadwood, borers

No 13 Park Road, Wallacia

Tag No.	Common Name	Scientific Name	DBH	BD (cm)	Height (m)	Spread (m)	Vigour (%)	SULE	TPZ Radius (m)	SRZ Radius (m)	Ret/Rem	Reason	Visual Sig	Habitat Tree	Comments
T46	Radiata Pine	<i>Pinus radiata</i>	38	35	12	6	80	3c	4.53	2.13	Retain				suppressed above, deadwood
T47	Grey Gum	<i>Eucalyptus punctata</i>	58	55	22	10	80	2a	6.96	2.57	Retain				borers at base, deadwood, damage cambium
T48	Grey Gum	<i>Eucalyptus punctata</i>	50	60	22	10	70	3c	6.00	2.67	Retain				damage cambium, broken branch, deadwood
T49	Grey Gum	<i>Eucalyptus punctata</i>	26	28	18	5	85	2a	3.12	1.94	Retain				new canopy, crowded, deadwood
T50	Radiata Pine	<i>Pinus radiata</i>	75	90	18	12	80	2a	9.00	3.17	Retain				suppressed, damage cambium, kino
T51	Tallowwood	<i>Eucalyptus microcorys</i>	53	58	20	12	90	1a	6.36	2.63	Retain				
T52	Grey Gum	<i>Eucalyptus punctata</i>	56	60	23	14	90	2a	6.72	2.67	Retain				broken branches
T53	Radiata Pine	<i>Pinus radiata</i>	70	90	23	9	85	2a	8.40	3.17	Retain				deadwood, kino
T54	Forest Red Gum	<i>Eucalyptus tereticornis</i>	66	60	21	11	90	2a	7.92	2.67	Retain				deadwood, damage cambium
T55	Swamp Mahogany	<i>Eucalyptus robusta</i>	34	40	19	9	75	3c	4.08	2.25	Retain				bracket fungi, deadwood, suppressed
T56	Forest Red Gum	<i>Eucalyptus tereticornis</i>	43	40	22	10	85	2a	5.19	2.25	Retain				borers at base
T57	Radiata Pine	<i>Pinus radiata</i>	55	75	16	10	85	2a	6.60	2.93	Retain				suppressed above, kino
T58	Forest Red Gum	<i>Eucalyptus tereticornis</i>	60	60	22	9	90	2a	7.20	2.67	Retain				crowded
T59	Forest Red Gum	<i>Eucalyptus tereticornis</i>	33	37	23	8	85	2d	3.96	2.18	Retain				deadwood, borers
T60	Cabbage Gum	<i>Eucalyptus amplifolia</i>	44	40	18	6	90	2a	5.34	2.25	Remove	Golf Cse			
T61	Swamp Mahogany	<i>Eucalyptus robusta</i>	57	62	24	10	90	2a	6.84	2.71	Retain				deadwood
T62	Forest Red Gum	<i>Eucalyptus tereticornis</i>	29	33	19	6	70	3c	3.48	2.08	Retain				suppressed above, lots small deadwood, kino
T63	a Mahogany	<i>Eucalyptus sp. (non-endemic)</i>	51	50	20	10	85	2a	6.07	2.47	Retain				deadwood, broken branches, crowded
T64	Grey Gum	<i>Eucalyptus punctata</i>	76	65	25	14	90	2a	9.12	2.76	Retain		V3		broken branch, deadwood
T65	Swamp Mahogany	<i>Eucalyptus robusta</i>	37	38	20	7	70	3c	4.41	2.20	Retain				suppressed above, lots small deadwood,
T66	Cabbage Gum	<i>Eucalyptus amplifolia</i>	43	45	18	6	85	2a	5.16	2.37	Remove	Golf Cse			lots small deadwood
T67	Grey Gum	<i>Eucalyptus punctata</i>	30	38	18	9	90	2a	3.60	2.20	Remove	Golf Cse			
T68	Cabbage Gum	<i>Eucalyptus amplifolia</i>	33	40	17	5	70	3c	4.02	2.25	Remove	Golf Cse			small deadwood
T69	Grey Gum	<i>Eucalyptus punctata</i>	68	80	23	12	85	2a	8.16	3.01	Retain				burls, dehydrated bark, small deadwood
T70	Radiata Pine	<i>Pinus radiata</i>	60	65	24	11	85	2a	7.20	2.76	Retain				suppressed below, lots small deadwood
T71	Silky Oak	<i>Grevillea robusta</i>	46	60	23	7	80	2c	5.52	2.67	Retain				suppressed below, lots small deadwood, competition
T72	Large-leaved Privet	<i>Ligustrum lucidum</i>	26	30	9	4	50	3a	3.13	2.00	Retain				suppressed above
T73	Slash Pine	<i>Pinus elliotii</i>	25	28	14	5	70	3c	3.00	1.94	Retain				suppressed above & below, lots small deadwood
T74	Silky Oak	<i>Grevillea robusta</i>	40	55	17	7	75	3c	4.80	2.57	Retain				crowded, deadwood
T75	Large-leaved Privet	<i>Ligustrum lucidum</i>	12	19	7	3	45	4a	2.00	1.65	Remove	Health			suppressed
T76	Large-leaved Privet	<i>Ligustrum lucidum</i>	23	28	5	5	55	4a	2.82	1.94	Remove	Health			suppressed, deadwood
T77	Silky Oak	<i>Grevillea robusta</i>	31	41	17	10	80	2a	3.72	2.28	Retain				crowded, competition
T78	Radiata Pine	<i>Pinus radiata</i>	46	60	22	10	85	2a	5.52	2.67	Retain				
T79	Radiata Pine	<i>Pinus radiata</i>	40	50	21	8	65	3c	4.80	2.47	Retain				competition, lots deadwood
T80	Black Wattle	<i>Acacia decurrens</i>	26	30	20	8	40	4d	3.12	2.00	Remove	Health			lots small deadwood, kino, borers, leaning canopy
T81	Black Wattle	<i>Acacia decurrens</i>	19	22	19	4	20	4a	2.28	1.75	Remove	Health			damage cambium, lots small deadwood, reduced canopy, kino
T82	White Cedar	<i>Melia azedarach</i>	25	30	16	5	60	3a	3.00	2.00	Retain				crowded, suppressed
T83	Silky Oak	<i>Grevillea robusta</i>	48	54	21	11	70	3c	5.76	2.55	Retain				broken branches, kino, deadwood
T84	Silky Oak	<i>Grevillea robusta</i>	19	23	11	4	60	3c	2.28	1.79	Retain				suppressed above, lots small deadwood
T85	Grey Gum	<i>Eucalyptus punctata</i>	42	45	23	10	75	2d	5.04	2.37	Retain				competition, large broken branch,
T86	Silky Oak	<i>Grevillea robusta</i>	19	24	16	5	50	3c	2.28	1.82	Retain				crowded, suppressed above
T87	Weeping Bottlebrush	<i>Callistemon viminalis</i>	49	43	9	6	90	2a	5.88	2.32	Remove	Earthwks			small deadwood
T88	Weeping Bottlebrush	<i>Callistemon viminalis</i>	26	43	8	5	90	2a	3.17	2.32	Remove	Earthwks			small deadwood
T89	Weeping Bottlebrush	<i>Callistemon viminalis</i>	24	32	6	4	85	2a	2.88	2.05	Remove	Earthwks			small deadwood, broken branch
T90	Weeping Bottlebrush	<i>Callistemon viminalis</i>	23	26	6	4	80	2a	2.72	1.88	Remove	Earthwks			

No 13 Park Road, Wallacia

Tag No.	Common Name	Scientific Name	DBH	BD (cm)	Height (m)	Spread (m)	Vigour (%)	SULE	TPZ Radius (m)	SRZ Radius (m)	Ret/Rem	Reason	Visual Sig	Habitat Tree	Comments
T91	Monterey Cypress	<i>Cupressus macrocarpa</i>	40	48	9	5	90	2a	4.80	2.43	Remove	Dev			small deadwood
T92	Weeping Bottlebrush	<i>Callistemon viminalis</i>	30	38	5	3	70	3a	3.58	2.20	Remove	Earthwks			dying trunk spout, deadwood
T93	Broad-leaved paperbark	<i>Melaleuca quinquenervia</i>	70	75	16	5	90	2a	8.40	2.93	Retain				
T94	a Paperbark	<i>Melaleuca sp.</i>	57	55	13	6	90	2a	6.83	2.57	Retain				broken small branch
T95	Broad-leaved paperbark	<i>Melaleuca quinquenervia</i>	94	105	20	10	90	2a	11.28	3.38	Retain				
T96	a Paperbark	<i>Melaleuca sp.</i>	48	45	11	5	85	2a	5.75	2.37	Retain				
T97	Dead Stag	Dead Stag	110	120	12	0	0	4a	13.20	3.57	Remove	Health			
T98	Dead Stag	Dead Stag	115	130	16	10	0	4a	13.80	3.69	Remove	Dev			
T99	Dead Stag	Dead Stag	23	30	8	3	0	4a	2.81	2.00	Remove	Health			
T100	Silky Oak	<i>Grevillea robusta</i>	13	15	6	2	70	3c	2.00	1.49	Remove	Dev			crowded
T101	Sydney Green Wattle	<i>Acacia parramattensis</i>	15	17	6	5	30	4a	2.00	1.57	Remove	Health			leaning canopy, lots small deadwood, competition
T102	Sydney Green Wattle	<i>Acacia parramattensis</i>	25	35	9	4	50	3c	3.00	2.13	Retain				crowded, lots small deadwood, reduced canopy
T103	Sydney Green Wattle	<i>Acacia parramattensis</i>	14	17	8	3	70	3a	2.00	1.57	Retain				crowded, deadwood
T104	Dead Stag	Dead Stag	14	15	4	0	0	4a	2.00	1.49	Remove	Health			
T105	Sydney Green Wattle	<i>Acacia parramattensis</i>	26	40	5	5	30	4a	3.10	2.25	Remove	Health			dead limbs and trunk, kino
T106	Sydney Green Wattle	<i>Acacia parramattensis</i>	16	15	6	3	50	3c	2.00	1.49	Retain				kino, small deadwood, crowded
T107	Sydney Green Wattle	<i>Acacia parramattensis</i>	15	15	7	4	60	3a	2.00	1.49	Remove	Golf Cse			kino, crowded, lots small deadwood
T108	Sydney Green Wattle	<i>Acacia parramattensis</i>	15	0	8	4	60	3a	2.00	0.00	Remove	Golf Cse			crowded, lots small deadwood
T109	Sydney Green Wattle	<i>Acacia parramattensis</i>	21	22	9	4	70	3a	2.52	1.75	Retain				crowded
T110	Swamp Oak	<i>Casuarina glauca</i>	22	25	20	5	80	2c	2.64	1.85	Retain				crowded, kink in trunk
T111	Swamp Oak	<i>Casuarina glauca</i>	17	25	20	5	85	2a	2.04	1.85	Retain				crowded
T112	Swamp Oak	<i>Casuarina glauca</i>	16	20	16	4	65	3c	2.00	1.68	Retain				competition, suppressed above
T113	Swamp Oak	<i>Casuarina glauca</i>	28	33	21	6	85	2a	3.36	2.08	Retain				weedy understory
T114	Swamp Oak	<i>Casuarina glauca</i>	23	30	20	5	85	2a	2.76	2.00	Retain				small deadwood
T115	Grey Gum	<i>Eucalyptus punctata</i>	20	35	17	4	80	2a	2.40	2.13	Retain				small deadwood
T116	Dead Stag	Dead Stag	21	30	14	5	0	4a	2.53	2.00	Remove	Health			
T117	Rough-barked Apple	<i>Angophora floribunda</i>	18	20	15	5	90	2a	2.16	1.68	Retain				crowded
T118	Rough-barked Apple	<i>Angophora floribunda</i>	15	16	14	4	85	2a	2.00	1.53	Retain				crowded
T119	Swamp Oak	<i>Casuarina glauca</i>	43	50	23	6	85	2a	5.16	2.47	Retain				small deadwood, crowded
T120	Swamp Oak	<i>Casuarina glauca</i>	26	33	22	4	85	2a	3.12	2.08	Retain				suppressed above, crowded
T121	Forest Red Gum	<i>Eucalyptus tereticornis</i>	117	137	24	11	85	2a	14.04	3.78	Retain				small to medium deadwood
T122	Forest Red Gum	<i>Eucalyptus tereticornis</i>	98	105	25	15	90	2a	11.76	3.38	Retain		V2		crowded
T123	Swamp Oak	<i>Casuarina glauca</i>	26	35	17	4	85	2a	3.12	2.13	Retain				suppressed above, small deadwood
T124	Sydney Green Wattle	<i>Acacia parramattensis</i>	15	16	6	4	65	3b	2.00	1.53	Remove	Health			leaning canopy, kino, lots small deadwood
T125	Sydney Green Wattle	<i>Acacia parramattensis</i>	16	16	6	5	50	3b	2.00	1.53	Remove	Health			large broken branch, leaning canopy, kino, deadwood
T126	Swamp Oak	<i>Casuarina glauca</i>	12	16	11	8	60	3b	2.00	1.53	Remove	Health			heavily leaning canopy, small deadwood
T127	Forest Red Gum	<i>Eucalyptus tereticornis</i>	27	30	16	5	90	2a	3.24	2.00	Retain				crowded, small deadwood
T128	Swamp Oak	<i>Casuarina glauca</i>	16	18	14	3	85	2a	2.00	1.61	Retain				small deadwood, suppressed above
T129	Dead Stag	Dead Stag	16	16	5	4	0	4a	2.00	1.53	Remove	Health			
T130	Grey Gum	<i>Eucalyptus punctata</i>	13	14	13	3	80	2a	2.00	1.45	Retain				suppressed above
T131	Camphor Laurel	<i>Cinnamomum camphora</i>	53	100	23	8	80	3c	6.41	3.31	Remove	Weed			suppressed above, competition
T132	Silky Oak	<i>Grevillea robusta</i>	16	23	6	4	25	4a	2.00	1.79	Remove	Health			lots small deadwood, suppressed above, medium dead branches
T133	Forest Red Gum	<i>Eucalyptus tereticornis</i>	180	230	32	25	90	1c	21.60	4.70	Retain		V1	Cat-1	deadwood,
T134	Swamp Oak	<i>Casuarina glauca</i>	29	35	24	6	90	2a	3.48	2.13	Retain				crowded, weedy understory
T135	Swamp Oak	<i>Casuarina glauca</i>	45	55	23	7	90	2a	5.40	2.57	Retain				

No 13 Park Road, Wallacia

Tag No.	Common Name	Scientific Name	DBH	BD (cm)	Height (m)	Spread (m)	Vigour (%)	SULE	TPZ Radius (m)	SRZ Radius (m)	Ret/Rem	Reason	Visual Sig	Habitat Tree	Comments
T136	Swamp Oak	<i>Casuarina glauca</i>	21	23	22	6	90	2a	2.52	1.79	Retain				
T137	Camphor Laurel	<i>Cinnamomum camphora</i>	67	90	24	11	85	2c	8.07	3.17	Remove	Weed			lots small deadwood, crowded
T138	Rough-barked Apple	<i>Angophora floribunda</i>	12	13	11	3	80	2d	2.00	1.40	Retain				competition, small deadwood
T139	Rough-barked Apple	<i>Angophora floribunda</i>	14	16	14	2	80	2a	2.00	1.53	Retain				crowded
T140	Rough-barked Apple	<i>Angophora floribunda</i>	11	13	12	2	80	2d	2.00	1.40	Retain				weedy understorey, crowded
T141	White Sally	<i>Acacia floribunda</i>	14	18	4	3	60	3a	2.00	1.61	Remove	Golf Cse			competition, leaning canopy, damage cambium
T142	Swamp Oak	<i>Casuarina glauca</i>	11	18	6	2	75	3c	2.00	1.61	Remove	Golf Cse			suppressed above
T143	Canary Island Date Palm	<i>Phoenix canariensis</i>	120	90	5	4	90	3a	14.40	3.17	Remove	Golf Cse			
T144	Swamp Oak	<i>Casuarina glauca</i>	28	46	19	6	75	2c	3.36	2.39	Remove	Golf Cse			suppressed above, leaning canopy
T145	Swamp Oak	<i>Casuarina glauca</i>	40	70	17	13	70	3b	4.75	2.85	Remove	Health			lots small deadwood, heavily leaning canopy, damage cambium
T146	Forest Red Gum	<i>Eucalyptus tereticornis</i>	100	115	30	20	85	3c	12.00	3.51	Remove	Golf Cse	V1		bracket fungi on main trunk, small-medium deadwood
T147	River Oak	<i>Casuarina cunninghamiana</i>	27	44	11	6	65	3c	3.24	2.34	Remove	Golf Cse			suppressed above, leaning canopy, deadwood
T148	Sydney Green Wattle	<i>Acacia parramattensis</i>	18	22	4	6	55	3b	2.16	1.75	Remove	Health			heavily leaning canopy, deadwood
T149	Swamp Oak	<i>Casuarina glauca</i>	24	27	20	4	80	2c	2.88	1.91	Remove	Golf Cse			small-medium deadwood, suppressed above
T150	Forest Red Gum	<i>Eucalyptus tereticornis</i>	90	110	30	12	85	2a	10.85	3.44	Remove	Golf Cse			small-medium deadwood
T151	Forest Red Gum	<i>Eucalyptus tereticornis</i>	35	40	22	0	10	3c	4.20	2.25	Remove	Health			leaning canopy, suppressed above
T152	Swamp Oak	<i>Casuarina glauca</i>	24	25	16	4	85	2a	2.86	1.85	Retain				
T153	Swamp Oak	<i>Casuarina glauca</i>	62	85	23	6	75	4d	7.40	3.09	Remove	Health			broken trunk, bracket fungi, deadwood, leaning canopy
T154	Swamp Oak	<i>Casuarina glauca</i>	31	50	18	7	70	4d	3.74	2.47	Remove	Health			heavily leaning canopy, bracket fungi, damage cambium
T155	Swamp Oak	<i>Casuarina glauca</i>	24	34	22	6	80	2a	2.88	2.10	Retain				leaning canopy
T156	Dead Stag	Dead Stag	47	77	5	10	0	4a	5.64	2.97	Remove	Health			
T157	Swamp Oak	<i>Casuarina glauca</i>	17	15	7	2	45	4a	2.04	1.49	Remove	Health			suppressed above, broken trunk
T158	Swamp Oak	<i>Casuarina glauca</i>	24	32	19	5	80	2a	2.89	2.05	Retain				crowded
T159	Swamp Oak	<i>Casuarina glauca</i>	14	18	15	3	70	4c	2.00	1.61	Remove	Health			damage cambium, bracket fungi
T160	Swamp Oak	<i>Casuarina glauca</i>	17	24	20	4	85	2a	2.04	1.82	Retain				crowded
T161	Swamp Oak	<i>Casuarina glauca</i>	22	26	18	4	90	2a	2.64	1.88	Retain				crowded
T162	Swamp Oak	<i>Casuarina glauca</i>	35	42	23	6	75	3c	4.20	2.30	Retain				lots small deadwood, competition
T163	Rough-barked Apple	<i>Angophora floribunda</i>	26	23	15	5	80	2c	3.14	1.79	Retain				suppressed above, leaning canopy
T164	River Oak	<i>Casuarina cunninghamiana</i>	14	21	20	4	85	2a	2.00	1.72	Retain				crowded
T165	Rough-barked Apple	<i>Angophora floribunda</i>	25	30	14	5	60	3b	3.00	2.00	Remove	Health			damage cambium @ base, small deadwood, suppressed above
T166	Rough-barked Apple	<i>Angophora floribunda</i>	20	23	13	5	75	2c	2.40	1.79	Retain				suppressed above, small deadwood
T167	River Oak	<i>Casuarina cunninghamiana</i>	20	25	20	5	90	2a	2.40	1.85	Retain				crowded
T168	Forest Red Gum	<i>Eucalyptus tereticornis</i>	33	35	12	6	80	2a	3.96	2.13	Retain				small deadwood
T169	Tallowwood	<i>Eucalyptus microcorys</i>	91	99	24	10	90	2a	10.92	3.30	Retain				small deadwood
T170	Tallowwood	<i>Eucalyptus microcorys</i>	93	100	26	11	90	2a	11.16	3.31	Retain				small deadwood
T171	Radiata Pine	<i>Pinus radiata</i>	93	98	23	13	85	2c	11.16	3.28	Retain		V2		small-large deadwood
T172	Silver Birch	<i>Betula pendula</i>	71	100	20	15	80	2a	8.52	3.31	Retain		V2		
T173	Jacaranda	<i>Jacaranda mimosifolia</i>	25	29	6	6	85	2a	3.00	1.97	Remove	Earthwks			
T174	Chinese Tallow	<i>Sapium sebiferum</i>	35	56	13	8	80	3b	4.15	2.59	Remove	Health			exposed wood at 0 and 1m, borers
T175	Radiata Pine	<i>Pinus radiata</i>	68	78	13	10	80	2a	8.16	2.98	Remove	Earthwks			
T176	Dead Stag	Dead Stag	85	105	16	9	0	4a	10.20	3.38	Remove	Health			
T177	a Bottlebrush	<i>Callistemon sp.</i>	20	27	4	3	60	3b	2.36	1.91	Remove	Health			exposed wood 0-0.3m
T178	Radiata Pine	<i>Pinus radiata</i>	47	63	23	9	80	2a	5.64	2.73	Retain				
T179	River Oak	<i>Casuarina cunninghamiana</i>	52	62	24	8	85	2a	6.24	2.71	Retain				
T180	River Oak	<i>Casuarina cunninghamiana</i>	42	52	23	7	80	3a	5.04	2.51	Retain				in creek bank, leaning 15 degrees

No 13 Park Road, Wallacia

Tag No.	Common Name	Scientific Name	DBH	BD (cm)	Height (m)	Spread (m)	Vigour (%)	SULE	TPZ Radius (m)	SRZ Radius (m)	Ret/Rem	Reason	Visual Sig	Habitat Tree	Comments
T181	White Sally	<i>Acacia floribunda</i>	16	31	4	5	35	4c	2.00	2.02	Remove	Health			borers in most trunks
T182	Exotic planted tree 1	-	83	105	24	14	85	2a	9.96	3.38	Remove	Earthwks	V3		
T183	Small-leaved Privet	<i>Ligustrum sinense</i>	13	18	8	6	80	2a	2.00	1.61	Remove	Weed			
T184	River Oak	<i>Casuarina cunninghamiana</i>	130	130	24	12	65	3b	15.60	3.69	Remove	Health			cavities at 1 to 2m, borers, leaning 15 degrees
T185	River Oak	<i>Casuarina cunninghamiana</i>	52	72	24	11	80	2a	6.24	2.88	Retain				
T186	River Oak	<i>Casuarina cunninghamiana</i>	21	26	16	5	90	2a	2.52	1.88	Retain				
T187	River Oak	<i>Casuarina cunninghamiana</i>	16	22	16	5	60	3c	2.00	1.75	Retain				crowded, suppressed, bark damage & exposed wood at 1.8m
T188	River Oak	<i>Casuarina cunninghamiana</i>	11	16	14	4	80	2a	2.00	1.53	Retain				
T189	River Oak	<i>Casuarina cunninghamiana</i>	16	18	16	5	70	3c	2.00	1.61	Retain				crowded, suppressed, canopy off centre
T190	River Oak	<i>Casuarina cunninghamiana</i>	21	27	20	7	85	2a	2.52	1.91	Retain				
T191	River Oak	<i>Casuarina cunninghamiana</i>	24	32	20	7	75	3c	2.88	2.05	Retain				in creek bank, leaning
T192	Exotic planted tree 2	-	87	107	25	20	85	2a	10.44	3.40	Retain		V1		
T193	Exotic planted tree 2	-	63	83	24	18	80	2a	7.56	3.06	Remove	Golf Cse	V2		
T194	River Oak	<i>Casuarina cunninghamiana</i>	34	38	17	7	90	2a	4.08	2.20	Retain				
T195	River Oak	<i>Casuarina cunninghamiana</i>	32	40	22	8	85	2a	3.85	2.25	Retain				
T196	River Oak	<i>Casuarina cunninghamiana</i>	20	26	22	7	80	2a	2.40	1.88	Retain				
T197	River Oak	<i>Casuarina cunninghamiana</i>	18	22	10	8	50	3b	2.16	1.75	Remove	Health			crowded, suppressed, canopy off centre
T198	River Oak	<i>Casuarina cunninghamiana</i>	29	28	21	6	80	2a	3.50	1.94	Retain				
T199	Box Elder	<i>Acer negundo</i>	12	15	6	4	90	2a	2.00	1.49	Retain				
T200	River Oak	<i>Casuarina cunninghamiana</i>	17	21	17	4	85	2a	2.04	1.72	Retain				slightly crowded
T201	River Oak	<i>Casuarina cunninghamiana</i>	23	29	21	4	80	2a	2.76	1.97	Retain				crowded
T202	River Oak	<i>Casuarina cunninghamiana</i>	27	33	20	5	85	2a	3.24	2.08	Retain				
T203	River Oak	<i>Casuarina cunninghamiana</i>	11	14	12	3	90	2a	2.00	1.45	Retain				
T204	River Oak	<i>Casuarina cunninghamiana</i>	11	14	8	3	70	3c	2.00	1.45	Retain				crowded, suppressed
T205	River Oak	<i>Casuarina cunninghamiana</i>	43	52	24	7	90	2a	5.16	2.51	Retain				
T206	River Oak	<i>Casuarina cunninghamiana</i>	25	33	20	7	75	3c	2.98	2.08	Remove	Health			crowded, suppressed
T207	River Oak	<i>Casuarina cunninghamiana</i>	18	22	17	6	60	3c	2.16	1.75	Remove	Health			crowded, suppressed, leaning 15deg
T208	River Oak	<i>Casuarina cunninghamiana</i>	56	65	24	9	60	4c	6.72	2.76	Remove	Health			cavity at base, exposed wood, borers in trunk
T209	River Oak	<i>Casuarina cunninghamiana</i>	38	39	24	7	65	4c	4.57	2.23	Remove	Health			cavity at base, exposed wood, leaning 10 degrees
T210	River Oak	<i>Casuarina cunninghamiana</i>	14	21	10	3	80	2a	2.00	1.72	Retain				
T211	River Oak	<i>Casuarina cunninghamiana</i>	18	23	9	3	75	3c	2.16	1.79	Remove	Health			crowded, suppressed
T212	Weeping Willow	<i>Salix babylonica</i>	54	64	7	7	85	3a	6.48	2.74	Remove	Weed			
T213	River Oak	<i>Casuarina cunninghamiana</i>	32	36	24	8	90	2a	3.84	2.15	Retain				
T214	River Oak	<i>Casuarina cunninghamiana</i>	68	86	24	15	80	2a	8.15	3.11	Retain		V2		
T215	River Oak	<i>Casuarina cunninghamiana</i>	24	31	20	4	70	4c	2.88	2.02	Remove	Health			exposed wood 1.5-2m, leaning on adjacent tree, poor form
T216	River Oak	<i>Casuarina cunninghamiana</i>	25	31	19	4	80	2a	3.00	2.02	Retain				
T217	River Oak	<i>Casuarina cunninghamiana</i>	31	32	23	4	70	3c	3.73	2.05	Retain				crowded, suppressed, canopy off centre
T218	River Oak	<i>Casuarina cunninghamiana</i>	45	51	24	8	90	2a	5.40	2.49	Retain				
T219	River Oak	<i>Casuarina cunninghamiana</i>	39	44	22	7	85	2a	4.68	2.34	Retain				
T220	River Oak	<i>Casuarina cunninghamiana</i>	84	75	24	14	70	3b	10.11	2.93	Remove	Health	V3		overmature, poor form, large deadwood
T221	River Oak	<i>Casuarina cunninghamiana</i>	18	23	17	5	90	2a	2.16	1.79	Retain				
T222	River Oak	<i>Casuarina cunninghamiana</i>	25	28	18	6	80	3b	3.05	1.94	Retain				cavity & exposed wood at 0.5m
T223	River Oak	<i>Casuarina cunninghamiana</i>	35	34	19	5	70	3a	4.21	2.10	Retain				poor form
T224	River Oak	<i>Casuarina cunninghamiana</i>	19	23	18	5	90	2a	2.28	1.79	Retain				
T225	River Oak	<i>Casuarina cunninghamiana</i>	30	33	19	7	80	2a	3.60	2.08	Retain				

No 13 Park Road, Wallacia

Tag No.	Common Name	Scientific Name	DBH	BD (cm)	Height (m)	Spread (m)	Vigour (%)	SULE	TPZ Radius (m)	SRZ Radius (m)	Ret/Rem	Reason	Visual Sig	Habitat Tree	Comments
T226	River Oak	<i>Casuarina cunninghamiana</i>	19	24	20	4	70	3c	2.28	1.82	Retain				crowded, suppressed
T227	River Oak	<i>Casuarina cunninghamiana</i>	46	53	20	7	80	2a	5.52	2.53	Retain				
T228	River Oak	<i>Casuarina cunninghamiana</i>	25	36	16	5	65	3b	3.06	2.15	Retain				cavity at 1m, exposed wood, fungal attack
T229	Silver Birch	<i>Betula pendula</i>	31	38	21	7	85	2a	3.72	2.20	Retain				leaning 15 degrees
T230	Silver Birch	<i>Betula pendula</i>	44	64	20	9	60	3b	5.28	2.74	Remove	Health			cavity at base, exposed wood, termites
T231	Silver Birch	<i>Betula pendula</i>	21	26	18	8	50	3b	2.52	1.88	Remove	Health			poor form, leaning 15 degrees, canopy off centre
T232	River Oak	<i>Casuarina cunninghamiana</i>	18	23	17	4	90	2a	2.16	1.79	Retain				
T233	Silver Birch	<i>Betula pendula</i>	41	45	12	8	60	3b	4.92	2.37	Remove	Health			leaning 45 degrees, epicormic growth
T234	Silver Birch	<i>Betula pendula</i>	22	28	19	6	75	3b	2.64	1.94	Remove	Health			leaning 15 degrees
T235	Silver Birch	<i>Betula pendula</i>	36	37	20	7	80	3a	4.33	2.18	Retain				
T236	Silver Birch	<i>Betula pendula</i>	22	25	20	6	60	3b	2.64	1.85	Remove	Health			leaning 15 degrees, canopy off centre
T237	Silver Birch	<i>Betula pendula</i>	37	46	21	8	70	3b	4.44	2.39	Remove	Health			leaning 15 degrees, stressed at trunk join at 0.5m
T238	River Oak	<i>Casuarina cunninghamiana</i>	72	75	22	13	50	3b	8.64	2.93	Remove	Health	V3		1x trunk 10% health, exposed wood, fungal attack
T239	River Oak	<i>Casuarina cunninghamiana</i>	26	30	22	4	80	2a	3.12	2.00	Retain				
T240	River Oak	<i>Casuarina cunninghamiana</i>	33	37	23	7	80	2a	3.96	2.18	Retain				
T241	River Oak	<i>Casuarina cunninghamiana</i>	30	34	23	6	80	2a	3.60	2.10	Retain				
T242	River Oak	<i>Casuarina cunninghamiana</i>	19	25	20	4	70	2a	2.28	1.85	Retain				crowded
T243	River Oak	<i>Casuarina cunninghamiana</i>	18	24	19	4	80	2a	2.20	1.82	Retain				crowded
T244	River Oak	<i>Casuarina cunninghamiana</i>	28	38	22	6	80	2a	3.33	2.20	Retain				crowded
T245	Tree Tag Number Not Used										Retain				
T246	Cabbage Gum	<i>Eucalyptus amplifolia</i>	53	73	22	14	80	2a	6.36	2.90	Remove	Dev			bark damage 0-2m
T247	Cabbage Gum	<i>Eucalyptus amplifolia</i>	94	124	25	17	85	2a	11.28	3.62	Remove	Dev	V2		Recently dropped major branches
T248	Forest Red Gum	<i>Eucalyptus tereticornis</i>	55	62	15	8	30	4a	6.66	2.71	Remove	Dev			bark separation, only 15% of canopy left, exposed wood
T249	Rough-barked Apple	<i>Angophora floribunda</i>	61	80	15	9	55	4c	7.34	3.01	Remove	Dev			bark damage, exposed wood, borers in trunk
T250	Forest Red Gum	<i>Eucalyptus tereticornis</i>	20	24	6	4	90	2a	2.40	1.82	Remove	Dev			
T251	Narrow-leaved Ironbark	<i>Eucalyptus crebra</i>	25	32	12	5	90	2a	2.97	2.05	Remove	Dev			
T252	Narrow-leaved Ironbark	<i>Eucalyptus crebra</i>	16	19	9	4	90	2a	2.00	1.65	Remove	Dev			
T253	Narrow-leaved Ironbark	<i>Eucalyptus crebra</i>	15	22	8	3	85	2a	2.00	1.75	Remove	Dev			
T254	Narrow-leaved Ironbark	<i>Eucalyptus crebra</i>	14	19	7	3	90	2a	2.00	1.65	Remove	Dev			
T255	Narrow-leaved Ironbark	<i>Eucalyptus crebra</i>	22	27	9	5	85	2a	2.63	1.91	Remove	Dev			
T256	Narrow-leaved Ironbark	<i>Eucalyptus crebra</i>	17	26	10	5	90	2a	2.04	1.88	Remove	Dev			
T257	Narrow-leaved Ironbark	<i>Eucalyptus crebra</i>	19	29	12	5	85	2a	2.31	1.97	Remove	Dev			lopped trunk at 1m, exposed wood
T258	Narrow-leaved Ironbark	<i>Eucalyptus crebra</i>	16	22	11	4	90	2a	2.00	1.75	Remove	Dev			
T259	Narrow-leaved Ironbark	<i>Eucalyptus crebra</i>	22	32	8	5	70	3c	2.68	2.05	Remove	Dev			poor form, multiple trunks at 0.2m
T260	Narrow-leaved Ironbark	<i>Eucalyptus crebra</i>	15	20	9	4	90	2a	2.00	1.68	Remove	Health			
T261	Forest Red Gum	<i>Eucalyptus tereticornis</i>	12	18	5	3	70	3b	2.00	1.61	Remove	Dev			poor form at 0m, twisted trunk, exposed roots
T262	Narrow-leaved Ironbark	<i>Eucalyptus crebra</i>	17	25	8	4	85	2a	2.04	1.85	Remove	Dev			2x trunks at 0.3m
T263	Narrow-leaved Ironbark	<i>Eucalyptus crebra</i>	23	31	9	4	80	3a	2.72	2.02	Remove	Dev			bark damage at base, healing ok
T264	Broad-leaved Ironbark	<i>Eucalyptus fibrosa</i>	14	19	6	4	90	2a	2.00	1.65	Remove	Dev			
T265	Broad-leaved Ironbark	<i>Eucalyptus fibrosa</i>	13	23	6	4	90	2a	2.00	1.79	Remove	Dev			
T266	Rough-barked Apple	<i>Angophora floribunda</i>	15	21	5	4	90	2a	2.00	1.72	Remove	Dev			
T267	Broad-leaved Ironbark	<i>Eucalyptus fibrosa</i>	11	14	5	3	80	2a	2.00	1.45	Retain				small deadwood, water stressed
T268	Broad-leaved Ironbark	<i>Eucalyptus fibrosa</i>	11	17	4	3	80	2a	2.00	1.57	Remove	Dev			
T269	Forest Red Gum	<i>Eucalyptus tereticornis</i>	23	30	9	5	65	4c	2.80	2.00	Remove	Dev			borers in base

No 13 Park Road, Wallacia

Tag No.	Common Name	Scientific Name	DBH	BD (cm)	Height (m)	Spread (m)	Vigour (%)	SULE	TPZ Radius (m)	SRZ Radius (m)	Ret/Rem	Reason	Visual Sig	Habitat Tree	Comments
T270	Broad-leaved Ironbark	<i>Eucalyptus fibrosa</i>	11	15	6	3	85	2a	2.00	1.49	Remove	Dev			small deadwood
T271	Broad-leaved Ironbark	<i>Eucalyptus fibrosa</i>	13	19	8	4	90	2a	2.00	1.65	Retain				
T272	Broad-leaved Ironbark	<i>Eucalyptus fibrosa</i>	14	21	6	3	90	2a	2.00	1.72	Retain				
T273	Broad-leaved Ironbark	<i>Eucalyptus fibrosa</i>	12	16	5	3	70	3a	2.00	1.53	Remove	Dev			lots med deadwood, water stressed
T274	Broad-leaved Ironbark	<i>Eucalyptus fibrosa</i>	16	22	10	4	90	2a	2.00	1.75	Remove	Dev			
T275	Grey Box	<i>Eucalyptus moluccana</i>	14	20	6	5	90	2a	2.00	1.68	Remove	Dev			
T276	Grey Box	<i>Eucalyptus moluccana</i>	12	24	7	5	70	4c	2.00	1.82	Remove	Dev			bark damage at base, exposed wood, borers in base
T277	Grey Box	<i>Eucalyptus moluccana</i>	14	22	7	4	75	4c	2.00	1.75	Remove	Dev			bark damage at base, exposed wood 0-0.5m
T278	Grey Box	<i>Eucalyptus moluccana</i>	11	14	7	3	90	2a	2.00	1.45	Remove	Dev			
T279	Grey Box	<i>Eucalyptus moluccana</i>	14	18	6	4	90	2a	2.00	1.61	Retain				
T280	Grey Box	<i>Eucalyptus moluccana</i>	10	14	4	2	70	3c	2.00	1.45	Retain				s shaped at base, structurally unsound, lots of med deadwood
T281	Grey Box	<i>Eucalyptus moluccana</i>	13	19	5	4	90	2a	2.00	1.65	Remove	Dev			
T282	Grey Box	<i>Eucalyptus moluccana</i>	13	18	6	4	90	2a	2.00	1.61	Remove	Dev			
T283	Grey Box	<i>Eucalyptus moluccana</i>	12	17	6	4	60	4c	2.00	1.57	Remove	Dev			bark damage 0-0.5m, exposed wood at base
T284	Grey Box	<i>Eucalyptus moluccana</i>	11	18	5	4	70	4c	2.00	1.61	Remove	Dev			bark damage & exposed wood 0-0.3m
T285	Grey Box	<i>Eucalyptus moluccana</i>	10	13	6	3	90	2a	2.00	1.40	Remove	Dev			
T286	Grey Box	<i>Eucalyptus moluccana</i>	12	15	7	4	90	2a	2.00	1.49	Retain				
T287	Grey Box	<i>Eucalyptus moluccana</i>	12	18	5	3	85	2a	2.00	1.61	Retain				2 trunks at 0.4m, small deadwood
T288	Grey Box	<i>Eucalyptus moluccana</i>	16	21	6	5	80	2a	2.00	1.72	Retain				stresses & kino at trunks joint 0.5m
T289	Grey Box	<i>Eucalyptus moluccana</i>	17	23	8	5	90	2a	2.04	1.79	Retain				
T290	Grey Box	<i>Eucalyptus moluccana</i>	12	18	9	5	90	2a	2.00	1.61	Remove	Dev			
T291	Grey Box	<i>Eucalyptus moluccana</i>	11	15	5	3	90	2a	2.00	1.49	Remove	Dev			
T292	Grey Box	<i>Eucalyptus moluccana</i>	14	17	6	4	90	2a	2.00	1.57	Remove	Dev			
T293	Grey Box	<i>Eucalyptus moluccana</i>	16	20	3	5	60	3b	2.00	1.68	Remove	Dev			main trunk snapped at 2m
T294	Grey Box	<i>Eucalyptus moluccana</i>	16	20	6	5	90	2a	2.00	1.68	Retain				
T295	Grey Box	<i>Eucalyptus moluccana</i>	13	18	6	4	90	2a	2.00	1.61	Retain				
T296	Grey Box	<i>Eucalyptus moluccana</i>	15	19	7	5	90	2a	2.00	1.65	Retain				
T297	Grey Box	<i>Eucalyptus moluccana</i>	16	21	7	4	80	2a	2.00	1.72	Remove	Dev			2 trunks at 0.2m, 3 trunks at 1.2m
T298	Grey Box	<i>Eucalyptus moluccana</i>	11	14	5	4	90	2a	2.00	1.45	Remove	Dev			
T299	Grey Box	<i>Eucalyptus moluccana</i>	13	15	8	4	90	2a	2.00	1.49	Remove	Dev			
T300	Grey Box	<i>Eucalyptus moluccana</i>	15	17	6	5	90	2a	2.00	1.57	Remove	Dev			
T301	Grey Box	<i>Eucalyptus moluccana</i>	13	18	8	4	90	2a	2.00	1.61	Remove	Dev			
T302	Grey Box	<i>Eucalyptus moluccana</i>	11	16	6	3	90	2a	2.00	1.53	Remove	Dev			
T303	Grey Box	<i>Eucalyptus moluccana</i>	16	21	9	4	90	2a	2.00	1.72	Remove	Health			
T304	Grey Box	<i>Eucalyptus moluccana</i>	11	19	6	4	75	3b	2.00	1.65	Retain				bark damage 0-0.5m, exposed wood
T305	Grey Box	<i>Eucalyptus moluccana</i>	14	19	8	4	90	2a	2.00	1.65	Retain				
T306	Grey Box	<i>Eucalyptus moluccana</i>	16	21	8	5	90	2a	2.00	1.72	Retain				
T307	Grey Box	<i>Eucalyptus moluccana</i>	23	23	8	6	80	2a	2.72	1.79	Retain				2x trunks at 1m
T308	Grey Box	<i>Eucalyptus moluccana</i>	15	20	5	5	80	2a	2.00	1.68	Retain				3x trunks at 0.7m
T309	Grey Box	<i>Eucalyptus moluccana</i>	17	22	7	5	80	2a	2.08	1.75	Retain				2x trunks at 0.4m, 3x trunks at 1m
T310	Grey Box	<i>Eucalyptus moluccana</i>	15	21	6	4	90	2a	2.00	1.72	Retain				
T311	Grey Box	<i>Eucalyptus moluccana</i>	13	19	5	5	90	2a	2.00	1.65	Retain				
T312	Grey Box	<i>Eucalyptus moluccana</i>	14	18	7	4	80	2a	2.00	1.61	Retain				2x trunks at 0.3m
T313	Grey Box	<i>Eucalyptus moluccana</i>	16	21	8	6	80	2a	2.00	1.72	Retain				2x trunks at 1m
T314	Grey Box	<i>Eucalyptus moluccana</i>	13	18	7	5	90	2a	2.00	1.61	Retain				

No 13 Park Road, Wallacia

Tag No.	Common Name	Scientific Name	DBH	BD (cm)	Height (m)	Spread (m)	Vigour (%)	SULE	TPZ Radius (m)	SRZ Radius (m)	Ret/Rem	Reason	Visual Sig	Habitat Tree	Comments
T315	Grey Box	<i>Eucalyptus moluccana</i>	28	33	10	7	80	2a	3.34	2.08	Remove	Health			2x trunks at 0.8m
T316	Grey Box	<i>Eucalyptus moluccana</i>	17	22	6	5	35	4d	2.04	1.75	Remove	Health			extensive golf ball damage on trunk, exposed wood, borers in trunk, lots kino
T317	Grey Box	<i>Eucalyptus moluccana</i>	12	15	5	4	90	4c	2.00	1.49	Retain				borers in trunk at 1.7m
T318	Grey Box	<i>Eucalyptus moluccana</i>	14	17	5	4	90	2a	2.00	1.57	Retain				
T319	Grey Box	<i>Eucalyptus moluccana</i>	16	18	7	6	90	2a	2.00	1.61	Retain				
T320	Grey Box	<i>Eucalyptus moluccana</i>	12	17	5	4	90	2a	2.00	1.57	Retain				
T321	Grey Box	<i>Eucalyptus moluccana</i>	14	20	5	4	90	2a	2.00	1.68	Remove	Health			
T322	Grey Box	<i>Eucalyptus moluccana</i>	16	20	6	4	70	4c	2.00	1.68	Retain				bark damage at base, termites in trunk
T323	Prickly-leaved Tea Tree	<i>Melaleuca stypheloides</i>	42	65	9	6	90	2a	5.07	2.76	Retain				
T324	Grey Box	<i>Eucalyptus moluccana</i>	17	21	8	4	90	2a	2.04	1.72	Retain				
T325	Grey Box	<i>Eucalyptus moluccana</i>	13	19	7	4	90	2a	2.00	1.65	Retain				
T326	Grey Box	<i>Eucalyptus moluccana</i>	20	26	15	6	69	2d	2.40	1.88	Retain				stressed, lots small deadwood, epicormic growth
T327	Grey Box	<i>Eucalyptus moluccana</i>	38	47	22	10	70	2a	4.56	2.41	Retain				sparse canopy
T328	Grey Box	<i>Eucalyptus moluccana</i>	52	72	23	14	75	3a	6.24	2.88	Remove	Health			stressed, epicormic growth lots small deadwood
T329	Grey Box	<i>Eucalyptus moluccana</i>	110	130	24	12	45	4c	13.20	3.69	Retain				stressed, lots epicormic growth & small deadwood, major dead trunk broken at 6m, termites in dead trunk
T330	Hickory Wattle	<i>Acacia implexa</i>	25	35	9	6	80	2a	3.00	2.13	Retain				crowded, canopy off centre
T331	Grey Box	<i>Eucalyptus moluccana</i>	10	14	4	4	45	2d	2.00	1.45	Remove	Health			stressed, lots epicormic growth, lots small deadwood, suppressed, canopy off centre
T332	Dead Stag	Dead Stag	17	22	9	5	0	4a	2.04	1.75	Retain				
T333	Grey Box	<i>Eucalyptus moluccana</i>	20	24	9	6	40	3d	2.40	1.82	Remove	Health			stressed, epicormic growth, lots small deadwood, crowded, canopy off centre, suppressed
T334	Dead Stag	Dead Stag	12	15	11	3	0	4a	2.00	1.49	Remove	Health			
T335	Grey Box	<i>Eucalyptus moluccana</i>	22	27	9	5	0	4a	2.64	1.91	Remove	Health			
T336	Grey Box	<i>Eucalyptus moluccana</i>	21	26	7	3	35	4a	2.52	1.88	Remove	Health			all major branches broken, lots epicormic growth, lots small deadwood, suppressed
T337	Hickory Wattle	<i>Acacia implexa</i>	11	18	6	4	70	4c	2.00	1.61	Retain				borers in trunk
T338	Grey Box	<i>Eucalyptus moluccana</i>	14	20	6	4	80	3a	2.00	1.68	Retain				suppressed
T339	Grey Box	<i>Eucalyptus moluccana</i>	39	44	22	10	80	2a	4.68	2.34	Retain				leaning 15 degrees, crowded
T340	Hickory Wattle	<i>Acacia implexa</i>	10	15	7	4	80	3a	2.00	1.49	Retain				
T341	Grey Box	<i>Eucalyptus moluccana</i>	45	65	25	10	80	2a	5.40	2.76	Retain				crowded
T342	Hickory Wattle	<i>Acacia implexa</i>	11	16	8	3	80	3a	2.00	1.53	Retain				
T343	Grey Box	<i>Eucalyptus moluccana</i>	31	38	25	9	90	2a	3.72	2.20	Retain				
T344	Hickory Wattle	<i>Acacia implexa</i>	12	17	7	3	80	3a	2.00	1.57	Retain				
T345	Hickory Wattle	<i>Acacia implexa</i>	16	22	8	4	80	3a	2.00	1.75	Retain				
T346	Hickory Wattle	<i>Acacia implexa</i>	17	26	8	4	80	3a	2.04	1.88	Retain				
T347	Hickory Wattle	<i>Acacia implexa</i>	13	18	7	4	80	3a	2.00	1.61	Retain				
T348	Grey Box	<i>Eucalyptus moluccana</i>	53	63	23	9	75	2a	6.36	2.73	Retain				crowded, canopy off centre, small deadwood, several mistletoes
T349	Grey Box	<i>Eucalyptus moluccana</i>	62	82	25	16	70	2a	7.44	3.04	Retain		V2		medium deadwood, lots epicormic growth
T350	Grey Box	<i>Eucalyptus moluccana</i>	19	21	9	4	75	3c	2.26	1.72	Retain				2x trunks at 0.5m, lots epicormic growth, lots small deadwood, stressed, suppressed
T351	Grey Box	<i>Eucalyptus moluccana</i>	49	69	25	8	65	3c	5.88	2.83	Retain				stressed, lots small deadwood & epicormic growth, several major branches broken, large deadwood
T352	Grey Box	<i>Eucalyptus moluccana</i>	66	86	24	12	65	3c	7.92	3.11	Remove	Health			stressed, lots epicormic growth and med deadwood, canopy off centre
T353	Dead Stag	Dead Stag	49	69	25	13	0	4a	5.88	2.83	Remove	Health			

No 13 Park Road, Wallacia

Tag No.	Common Name	Scientific Name	DBH	BD (cm)	Height (m)	Spread (m)	Vigour (%)	SULE	TPZ Radius (m)	SRZ Radius (m)	Ret/Rem	Reason	Visual Sig	Habitat Tree	Comments
T354	Grey Box	<i>Eucalyptus moluccana</i>	18	30	22	5	35	4a	2.16	2.00	Remove	Health			very stressed, dying, epicormic growth, lots small deadwood
T355	Dead Stag	Dead Stag	62	84	25	12	0	4a	7.44	3.08	Remove	Health			
T356	Dead Stag	Dead Stag	25	35	18	10	0	4a	3.00	2.13	Retain				
T357	Grey Box	<i>Eucalyptus moluccana</i>	20	28	9	5	60	3c	2.40	1.94	Retain				stressed, dying, lots med deadwood, epicormic growth, bark dmge & exposed wood 0-0.3m
T358	River Oak	<i>Casuarina cunninghamiana</i>	10	14	6	4	90	2a	2.00	1.45	Retain				
T359	River Oak	<i>Casuarina cunninghamiana</i>	11	18	7	3	90	2a	2.00	1.61	Retain				
T360	River Oak	<i>Casuarina cunninghamiana</i>	11	14	6	3	90	2a	2.00	1.45	Retain				
T361	River Oak	<i>Casuarina cunninghamiana</i>	12	18	6	4	80	2a	2.00	1.61	Retain				main trunk broken at 2m
T362	Grey Box	<i>Eucalyptus moluccana</i>	13	14	5	2	90	2a	2.00	1.45	Retain				
T363	Grey Box	<i>Eucalyptus moluccana</i>	15	17	5	2	90	2a	2.00	1.57	Remove	Dev			
T364	River Oak	<i>Casuarina cunninghamiana</i>	60	80	24	8	90	2a	7.20	3.01	Retain				
T365	Forest Red Gum	<i>Eucalyptus tereticornis</i>	53	60	23	12	80	2c	6.36	2.67	Retain				large broken branch, lots small deadwood, damage cambium, kino
T366	River Oak	<i>Casuarina cunninghamiana</i>	18	20	15	4	90	2a	2.16	1.68	Retain				suppressed above,
T367	River Oak	<i>Casuarina cunninghamiana</i>	18	24	16	5	90	2a	2.16	1.82	Retain				
T368	Grey Gum	<i>Eucalyptus punctata</i>	27	32	13	5	75	2c	3.20	2.05	Retain				small deadwood
T369	Hickory Wattle	<i>Acacia implexa</i>	11	18	9	1	70	3c	2.00	1.61	Retain				lots small deadwood, broken branches
T370	Hickory Wattle	<i>Acacia implexa</i>	13	18	11	4	60	3c	2.00	1.61	Remove	Dev			leaning canopy, lots small deadwood
T371	Hickory Wattle	<i>Acacia implexa</i>	17	25	10	2	80	3c	2.04	1.85	Remove	Dev			lots small deadwood, crowded, leaning canopy
T372	Hickory Wattle	<i>Acacia implexa</i>	16	20	8	2	80	3a	2.00	1.68	Remove	Dev			small deadwood
T373	River Oak	<i>Casuarina cunninghamiana</i>	43	50	13	8	80	2a	5.16	2.47	Remove	Dev			small deadwood
T374	River Oak	<i>Casuarina cunninghamiana</i>	28	38	13	7	80	2c	3.36	2.20	Retain				lots small deadwood, crowded
T375	River Oak	<i>Casuarina cunninghamiana</i>	33	50	13	5	70	3c	3.90	2.47	Remove	Dev			crowded, damage cambium, lots small deadwood
T376	River Oak	<i>Casuarina cunninghamiana</i>	38	50	15	6	80	2a	4.59	2.47	Retain				small deadwood
T377	River Oak	<i>Casuarina cunninghamiana</i>	22	25	13	5	75	3c	2.60	1.85	Retain				suppressed above, small deadwood
T378	River Oak	<i>Casuarina cunninghamiana</i>	43	62	13	6	85	2a	5.19	2.71	Retain				small deadwood
T379	River Oak	<i>Casuarina cunninghamiana</i>	36	60	13	6	80	2a	4.33	2.67	Retain				lots small deadwood
T380	River Oak	<i>Casuarina cunninghamiana</i>	19	23	10	4	70	3c	2.28	1.79	Remove	Health			suppressed above, new canopy, reduced foliage, deadwood
T381	River Oak	<i>Casuarina cunninghamiana</i>	27	40	14	6	25	4c	3.24	2.25	Retain				damage trunk cambium @ 4m, large broken branches, deadwood
T382	Grey Gum	<i>Eucalyptus punctata</i>	13	23	11	3	80	2c	2.00	1.79	Retain				suppressed above, small deadwood
T383	River Oak	<i>Casuarina cunninghamiana</i>	31	33	11	8	85	2a	3.75	2.08	Retain				small deadwood
T384	River Oak	<i>Casuarina cunninghamiana</i>	27	34	15	7	90	2a	3.24	2.10	Retain				small deadwood
T385	River Oak	<i>Casuarina cunninghamiana</i>	35	45	12	6	85	2a	4.22	2.37	Retain				small deadwood
T386	River Oak	<i>Casuarina cunninghamiana</i>	30	34	13	5	85	3b	3.60	2.10	Remove	Drainage			leaning trunk, deadwood, exposed wood
T387	River Oak	<i>Casuarina cunninghamiana</i>	29	43	12	9	85	2a	3.53	2.32	Remove	Drainage			small deadwood
T388	Grey Gum	<i>Eucalyptus punctata</i>	35	55	12	8	90	2a	4.16	2.57	Retain				
T389	River Oak	<i>Casuarina cunninghamiana</i>	33	34	11	5	85	2c	3.96	2.10	Retain				suppressed above, lots small deadwood
T390	River Oak	<i>Casuarina cunninghamiana</i>	32	47	15	8	90	2a	3.84	2.41	Retain				small deadwood
T391	River Oak	<i>Casuarina cunninghamiana</i>	39	42	13	8	85	2a	4.67	2.30	Retain				small deadwood
T392	River Oak	<i>Casuarina cunninghamiana</i>	10	13	10	2	90	2a	2.00	1.40	Retain				crowded
T393	River Oak	<i>Casuarina cunninghamiana</i>	40	50	14	9	85	2a	4.80	2.47	Remove	Drainage			small broken branches & deadwood
T394	River Oak	<i>Casuarina cunninghamiana</i>	15	18	7	2	90	2a	2.00	1.61	Retain				
T395	Tallowwood	<i>Eucalyptus microcorys</i>	74	95	20	11	90	2a	8.85	3.24	Remove	Dev			small deadwood
T396	Grey Gum	<i>Eucalyptus punctata</i>	20	22	6	3	85	2a	2.40	1.75	Remove	Dev			small deadwood
T397	Grey Gum	<i>Eucalyptus punctata</i>	35	40	9	6	90	2a	4.23	2.25	Remove	Dev			small deadwood, kino

No 13 Park Road, Wallacia

Tag No.	Common Name	Scientific Name	DBH	BD (cm)	Height (m)	Spread (m)	Vigour (%)	SULE	TPZ Radius (m)	SRZ Radius (m)	Ret/Rem	Reason	Visual Sig	Habitat Tree	Comments
T398	Forest Red Gum	<i>Eucalyptus tereticornis</i>	77	95	24	14	90	2a	9.24	3.24	Retain		V3		
T399	Forest Red Gum	<i>Eucalyptus tereticornis</i>	130	150	26	20	90	2a	15.60	3.92	Retain		V1		
T400	Forest Red Gum	<i>Eucalyptus tereticornis</i>	60	65	23	14	85	2a	7.20	2.76	Retain		V3		small deadwood
T401	Forest Red Gum	<i>Eucalyptus tereticornis</i>	20	26	18	5	80	2a	2.40	1.88	Retain				crowded
T402	Forest Red Gum	<i>Eucalyptus tereticornis</i>	33	43	22	10	80	2a	3.99	2.32	Retain				2x trunks at 0.5m
T403	Forest Red Gum	<i>Eucalyptus tereticornis</i>	23	29	20	9	90	2a	2.76	1.97	Retain				
T404	Forest Red Gum	<i>Eucalyptus tereticornis</i>	50	45	9	7	75	3c	6.00	2.37	Retain				major branch lopped, tilted 45 degrees at base, poor form
T405	River Oak	<i>Casuarina cunninghamiana</i>	29	36	13	7	90	2a	3.48	2.15	Retain				
T406	River Oak	<i>Casuarina cunninghamiana</i>	47	67	17	8	85	2a	5.64	2.80	Retain				
T407	River Oak	<i>Casuarina cunninghamiana</i>	25	38	9	7	80	2a	3.00	2.20	Retain				
T408	Hickory Wattle	<i>Acacia implexa</i>	11	15	6	3	90	3a	2.00	1.49	Retain				
T409	River Oak	<i>Casuarina cunninghamiana</i>	32	40	13	7	80	2a	3.79	2.25	Retain				
T410	River Oak	<i>Casuarina cunninghamiana</i>	25	31	13	7	90	2a	3.00	2.02	Retain				
T411	River Oak	<i>Casuarina cunninghamiana</i>	34	40	13	7	80	2a	4.03	2.25	Retain				2x trunks at 0.3m
T412	River Oak	<i>Casuarina cunninghamiana</i>	33	53	15	8	80	2a	3.96	2.53	Retain				
T413	River Oak	<i>Casuarina cunninghamiana</i>	32	48	14	7	80	2a	3.84	2.43	Retain				3x trunks at 0.3m
T414	River Oak	<i>Casuarina cunninghamiana</i>	48	60	15	10	80	2a	5.76	2.67	Retain				2x trunks at 1m
T415	River Oak	<i>Casuarina cunninghamiana</i>	27	35	13	6	90	2a	3.24	2.13	Retain				
T416	River Oak	<i>Casuarina cunninghamiana</i>	23	48	10	7	70	3b	2.80	2.43	Retain				10x trunks at 0.2m
T417	River Oak	<i>Casuarina cunninghamiana</i>	25	36	11	8	90	2a	3.00	2.15	Retain				
T418	River Oak	<i>Casuarina cunninghamiana</i>	22	28	12	6	90	2a	2.64	1.94	Retain				
T419	River Oak	<i>Casuarina cunninghamiana</i>	15	25	11	6	80	2a	2.00	1.85	Retain				
T420	River Oak	<i>Casuarina cunninghamiana</i>	21	27	12	8	90	2a	2.52	1.91	Retain				
T421	River Oak	<i>Casuarina cunninghamiana</i>	18	34	8	6	90	2a	2.16	2.10	Retain				
T422	River Oak	<i>Casuarina cunninghamiana</i>	24	42	10	6	90	2a	2.88	2.30	Retain				
T423	River Oak	<i>Casuarina cunninghamiana</i>	20	30	10	6	90	2a	2.40	2.00	Retain				
T424	River Oak	<i>Casuarina cunninghamiana</i>	30	33	12	6	90	2a	3.61	2.08	Retain				
T425	River Oak	<i>Casuarina cunninghamiana</i>	27	34	8	6	80	2a	3.21	2.10	Retain				
T426	River Oak	<i>Casuarina cunninghamiana</i>	14	23	8	4	90	2a	2.00	1.79	Retain				
T427	River Oak	<i>Casuarina cunninghamiana</i>	11	20	8	3	90	2a	2.00	1.68	Retain				
T428	River Oak	<i>Casuarina cunninghamiana</i>	39	46	14	9	90	2a	4.68	2.39	Retain				
T429	River Oak	<i>Casuarina cunninghamiana</i>	53	50	16	8	75	2a	6.31	2.47	Retain				4x trunks at 0.5m
T430	River Oak	<i>Casuarina cunninghamiana</i>	32	40	10	7	90	2a	3.84	2.25	Retain				
T431	River Oak	<i>Casuarina cunninghamiana</i>	12	15	11	4	90	2a	2.00	1.49	Retain				
T432	River Oak	<i>Casuarina cunninghamiana</i>	13	16	8	3	90	2a	2.00	1.53	Retain				
T433	River Oak	<i>Casuarina cunninghamiana</i>	23	41	12	6	90	2a	2.76	2.28	Retain				
T434	River Oak	<i>Casuarina cunninghamiana</i>	12	17	8	3	90	2a	2.00	1.57	Remove	Drainage			
T435	River Oak	<i>Casuarina cunninghamiana</i>	15	27	10	4	90	2a	2.00	1.91	Remove	Drainage			
T436	River Oak	<i>Casuarina cunninghamiana</i>	12	18	10	3	90	2a	2.00	1.61	Remove	Drainage			
T437	River Oak	<i>Casuarina cunninghamiana</i>	10	18	8	3	90	2a	2.00	1.61	Retain				
T438	River Oak	<i>Casuarina cunninghamiana</i>	12	18	8	3	90	2a	2.00	1.61	Retain				
T439	Grey Box	<i>Eucalyptus moluccana</i>	115	135	25	18	75	2a	13.80	3.75	Retain		V2		some epicormic growth
T440	Forest Red Gum	<i>Eucalyptus tereticornis</i>	37	43	22	11	90	2a	4.44	2.32	Retain				
T441	Grey Box	<i>Eucalyptus moluccana</i>	16	23	10	7	90	2a	2.00	1.79	Retain				
T442	Norfolk Island Hibiscus	<i>Lagunaria patersonii</i>	13	24	5	4	85	3a	2.00	1.82	Retain				

No 13 Park Road, Wallacia

Tag No.	Common Name	Scientific Name	DBH	BD (cm)	Height (m)	Spread (m)	Vigour (%)	SULE	TPZ Radius (m)	SRZ Radius (m)	Ret/Rem	Reason	Visual Sig	Habitat Tree	Comments
T443	River Oak	<i>Casuarina cunninghamiana</i>	11	17	7	3	90	2a	2.00	1.57	Retain				
T444	River Oak	<i>Casuarina cunninghamiana</i>	11	18	10	3	75	3c	2.00	1.61	Retain				twisted at base, poor form
T445	River Oak	<i>Casuarina cunninghamiana</i>	32	42	16	8	90	2a	3.84	2.30	Retain				
T446	River Oak	<i>Casuarina cunninghamiana</i>	31	41	14	9	90	2a	3.72	2.28	Retain				
T447	River Oak	<i>Casuarina cunninghamiana</i>	60	75	22	12	80	3a	7.26	2.93	Retain				4x stems at 0.3m
T448	River Oak	<i>Casuarina cunninghamiana</i>	29	38	20	7	80	2a	3.46	2.20	Retain				
T449	River Oak	<i>Casuarina cunninghamiana</i>	20	30	15	6	90	2a	2.40	2.00	Retain				
T450	River Oak	<i>Casuarina cunninghamiana</i>	41	61	22	12	90	2a	4.92	2.69	Retain				
T451	Forest Red Gum	<i>Eucalyptus tereticornis</i>	45	55	21	8	75	3c	5.40	2.57	Retain				kinked trunk, suppressed above, kino
T452	Forest Red Gum	<i>Eucalyptus tereticornis</i>	53	55	22	11	85	2a	6.38	2.57	Retain				small deadwood, crowded
T453	Forest Red Gum	<i>Eucalyptus tereticornis</i>	35	40	16	6	70	3c	4.17	2.25	Retain				lots small deadwood, suppressed above, exposed wood
T454	River Oak	<i>Casuarina cunninghamiana</i>	16	22	10	3	90	2a	2.00	1.75	Retain				crowded
T455	River Oak	<i>Casuarina cunninghamiana</i>	26	38	13	5	85	2a	3.12	2.20	Remove	Health			
T456	River Oak	<i>Casuarina cunninghamiana</i>	22	30	10	3	40	4a	2.68	2.00	Retain				lots small deadwood, low foliage, suppressed above, competition
T457	River Oak	<i>Casuarina cunninghamiana</i>	33	50	14	8	90	2a	3.91	2.47	Retain				small deadwood
T458	River Oak	<i>Casuarina cunninghamiana</i>	30	45	13	6	85	2c	3.61	2.37	Retain				small deadwood, suppressed above, leaning canopy
T459	River Oak	<i>Casuarina cunninghamiana</i>	34	36	12	5	85	2a	4.08	2.15	Retain				small deadwood
T460	River Oak	<i>Casuarina cunninghamiana</i>	10	13	9	2	85	2a	2.00	1.40	Retain				competition
T461	River Oak	<i>Casuarina cunninghamiana</i>	24	34	13	4	75	3c	2.88	2.10	Retain				crowded, competition, small deadwood, low foliage
T462	River Oak	<i>Casuarina cunninghamiana</i>	43	50	15	5	90	2a	5.17	2.47	Retain				small deadwood
T463	River Oak	<i>Casuarina cunninghamiana</i>	36	50	13	6	85	2a	4.32	2.47	Retain				small broken branch & deadwood
T464	Grey Box	<i>Eucalyptus moluccana</i>	16	20	9	4	85	2a	2.00	1.68	Remove	Health			crowded, small deadwood
T465	River Oak	<i>Casuarina cunninghamiana</i>	23	30	10	4	25	4a	2.74	2.00	Remove	Health			lots small deadwood, canopy dying
T466	River Oak	<i>Casuarina cunninghamiana</i>	23	30	11	7	35	4a	2.81	2.00	Remove	Health			canopy dying, suppressed below, lots small deadwood
T467	River Oak	<i>Casuarina cunninghamiana</i>	28	55	14	7	45	4a	3.41	2.57	Retain				dying canopy, lots small deadwood, competition
T468	River Oak	<i>Casuarina cunninghamiana</i>	30	34	13	5	65	3c	3.60	2.10	Remove	Health			lots small deadwood, crowded, reduced foliage
T469	River Oak	<i>Casuarina cunninghamiana</i>	20	23	9	2	5	4a	2.40	1.79	Remove	Health			no foliage, lots small deadwood, exposed wood
T470	Grey Gum	<i>Eucalyptus punctata</i>	34	40	18	10	70	4c	4.08	2.25	Retain				exposed wood at base, small deadwood, borers
T471	River Oak	<i>Casuarina cunninghamiana</i>	25	30	14	3	60	3c	3.00	2.00	Retain				suppressed above, small broken branches, deadwood
T472	River Oak	<i>Casuarina cunninghamiana</i>	28	35	12	4	75	3c	3.40	2.13	Remove	Health			lots small deadwood, broken branches, reduced canopy
T473	River Oak	<i>Casuarina cunninghamiana</i>	10	12	8	6	20	4c	2.00	1.36	Retain				heavily leaning canopy, deadwood
T474	River Oak	<i>Casuarina cunninghamiana</i>	30	38	15	6	75	3a	3.60	2.20	Retain				competition, low foliage, lots small deadwood
T475	River Oak	<i>Casuarina cunninghamiana</i>	22	28	15	5	75	3c	2.64	1.94	Retain				suppressed above, leaning canopy, lots small deadwood
T476	Forest Red Gum	<i>Eucalyptus tereticornis</i>	75	85	16	10	90	2a	9.01	3.09	Retain				kino, small deadwood
T477	River Oak	<i>Casuarina cunninghamiana</i>	17	19	9	3	80	3c	2.04	1.65	Retain				suppressed above, small deadwood
T478	River Oak	<i>Casuarina cunninghamiana</i>	22	30	13	5	85	2a	2.64	2.00	Retain				small deadwood
T479	River Oak	<i>Casuarina cunninghamiana</i>	20	28	11	6	80	2c	2.40	1.94	Retain				small deadwood, crowded
T480	River Oak	<i>Casuarina cunninghamiana</i>	17	23	10	3	50	3a	2.04	1.79	Remove	Health			suppressed above, lots small deadwood, reduced canopy
T481	Dead Stag	Dead Stag	20	27	10	2	0	4a	2.40	1.91	Retain				
T482	River Oak	<i>Casuarina cunninghamiana</i>	33	35	15	8	90	2a	3.96	2.13	Retain				small deadwood @ base
T483	Grey Box	<i>Eucalyptus moluccana</i>	10	12	12	3	70	3c	2.00	1.36	Retain				crowded, narrow canopy, lots small deadwood
T484	River Oak	<i>Casuarina cunninghamiana</i>	18	23	11	5	80	2a	2.16	1.79	Retain				small deadwood
T485	River Oak	<i>Casuarina cunninghamiana</i>	13	16	9	2	75	3c	2.00	1.53	Remove	Health			suppressed above, lots small deadwood
T486	Forest Red Gum	<i>Eucalyptus tereticornis</i>	57	75	19	12	75	4c	6.81	2.93	Retain				exposed wood, damage cambium ,small-medium deadwood
T487	Forest Red Gum	<i>Eucalyptus tereticornis</i>	122	130	20	16	90	2a	14.64	3.69	Retain		V2		small-medium deadwood

No 13 Park Road, Wallacia

Tag No.	Common Name	Scientific Name	DBH	BD (cm)	Height (m)	Spread (m)	Vigour (%)	SULE	TPZ Radius (m)	SRZ Radius (m)	Ret/Rem	Reason	Visual Sig	Habitat Tree	Comments
T488	River Oak	<i>Casuarina cunninghamiana</i>	20	23	10	4	85	2c	2.40	1.79	Retain				suppressed above, leaning canopy
T489	River Oak	<i>Casuarina cunninghamiana</i>	22	25	12	6	80	2a	2.63	1.85	Retain				small deadwood, crowded
T490	River Oak	<i>Casuarina cunninghamiana</i>	26	30	12	5	90	2a	3.12	2.00	Retain				small deadwood
T491	River Oak	<i>Casuarina cunninghamiana</i>	27	35	14	9	90	2a	3.20	2.13	Retain				small deadwood
T492	River Oak	<i>Casuarina cunninghamiana</i>	34	42	20	8	90	2a	4.08	2.30	Retain				
T493	River Oak	<i>Casuarina cunninghamiana</i>	15	20	9	2	90	2a	2.00	1.68	Remove	Dev			
T494	Radiata Pine	<i>Pinus radiata</i>	140	160	19	9	90	2a	16.80	4.03	Retain				small-medium deadwood, kino
T495	Grey Gum	<i>Eucalyptus punctata</i>	63	70	19	11	90	3b	7.56	2.85	Remove	Dev			exposed wood, borers, kino
T496	Forest Red Gum	<i>Eucalyptus tereticornis</i>	40	43	17	7	90	2a	4.80	2.32	Retain				
T497	Radiata Pine	<i>Pinus radiata</i>	116	136	17	8	90	2a	13.92	3.77	Retain				kino
T498	Forest Red Gum	<i>Eucalyptus tereticornis</i>	22	24	9	3	75	3c	2.64	1.82	Retain				exposed wood, deadwood
T499	Grey Gum	<i>Eucalyptus punctata</i>	33	40	17	7	90	3c	3.96	2.25	Remove	Earthwks			exposed wood, kino, small deadwood
T500	Liquidambar	<i>Liquidambar styraciflua</i>	60	75	18	5	90	2a	7.20	2.93	Retain				
T501	River Oak	<i>Casuarina cunninghamiana</i>	31	55	16	7	80	2a	3.70	2.57	Retain				3x trunks at 0.3m
T502	River Oak	<i>Casuarina cunninghamiana</i>	19	25	9	6	80	2a	2.28	1.85	Remove	Health			
T503	River Oak	<i>Casuarina cunninghamiana</i>	22	29	16	6	30	4a	2.64	1.97	Retain				dying, canopy 10% alive, cause unknown
T504	Grey Box	<i>Eucalyptus moluccana</i>	16	21	9	3	90	2a	2.00	1.72	Remove	Health			
T505	Dead Stag	Dead Stag	18	25	17	6	0	4a	2.16	1.85	Retain				
T506	River Oak	<i>Casuarina cunninghamiana</i>	30	38	18	9	80	2a	3.64	2.20	Remove	Health			3x trunks at 0.3m
T507	River Oak	<i>Casuarina cunninghamiana</i>	26	32	16	6	50	4a	3.14	2.05	Remove	Health			dying, top 20% of canopy still alive, cause unknown
T508	Dead Stag	Dead Stag	16	23	13	7	0	4a	2.00	1.79	Remove	Health			
T509	Dead Stag	Dead Stag	18	24	13	5	0	4a	2.16	1.82	Remove	Health			
T510	Dead Stag	Dead Stag	12	19	12	5	0	4a	2.00	1.65	Remove	Health			
T511	Dead Stag	Dead Stag	17	26	13	7	0	4a	2.04	1.88	Retain				
T512	River Oak	<i>Casuarina cunninghamiana</i>	16	21	13	6	60	3d	2.00	1.72	Retain				dying, sparse canopy, cause unknown
T513	River Oak	<i>Casuarina cunninghamiana</i>	14	16	12	7	80	2a	2.00	1.53	Retain				
T514	River Oak	<i>Casuarina cunninghamiana</i>	27	33	13	8	80	2a	3.24	2.08	Retain				
T515	River Oak	<i>Casuarina cunninghamiana</i>	36	36	15	9	80	2a	4.27	2.15	Retain				
T516	River Oak	<i>Casuarina cunninghamiana</i>	23	33	14	8	80	2a	2.76	2.08	Retain				
T517	River Oak	<i>Casuarina cunninghamiana</i>	19	36	13	6	75	3a	2.29	2.15	Remove	Health			3x trunks at 0.2m, sparse canopy
T518	Dead Stag	Dead Stag	17	25	10	7	0	4a	2.04	1.85	Remove	Health			
T519	River Oak	<i>Casuarina cunninghamiana</i>	18	25	8	5	65	4a	2.14	1.85	Retain				declining, sparse canopy
T520	River Oak	<i>Casuarina cunninghamiana</i>	22	31	10	7	80	2a	2.70	2.02	Retain				
T521	River Oak	<i>Casuarina cunninghamiana</i>	30	35	12	9	90	2a	3.60	2.13	Retain				
T522	River Oak	<i>Casuarina cunninghamiana</i>	21	37	12	6	80	3a	2.51	2.18	Retain				
T523	River Oak	<i>Casuarina cunninghamiana</i>	23	27	14	6	80	3a	2.80	1.91	Retain				sparse canopy, 2x trunks at 1m
T524	River Oak	<i>Casuarina cunninghamiana</i>	26	37	16	9	90	2a	3.12	2.18	Retain				
T525	River Oak	<i>Casuarina cunninghamiana</i>	25	29	12	7	80	2a	2.95	1.97	Retain				
T526	River Oak	<i>Casuarina cunninghamiana</i>	30	45	13	8	90	2a	3.54	2.37	Retain				
T527	River Oak	<i>Casuarina cunninghamiana</i>	15	27	6	4	80	2a	2.00	1.91	Retain				crowded
T528	River Oak	<i>Casuarina cunninghamiana</i>	25	35	15	9	90	2a	3.00	2.13	Remove	Health			
T529	Dead Stag	Dead Stag	21	28	12	9	0	4a	2.52	1.94	Retain				
T530	River Oak	<i>Casuarina cunninghamiana</i>	17	23	13	6	90	2a	2.04	1.79	Retain				
T531	River Oak	<i>Casuarina cunninghamiana</i>	16	23	12	6	80	2a	2.00	1.79	Remove	Health			
T532	Dead Stag	Dead Stag	14	22	9	4	0	4a	2.00	1.75	Retain				

No 13 Park Road, Wallacia

Tag No.	Common Name	Scientific Name	DBH	BD (cm)	Height (m)	Spread (m)	Vigour (%)	SULE	TPZ Radius (m)	SRZ Radius (m)	Ret/Rem	Reason	Visual Sig	Habitat Tree	Comments
T533	River Oak	<i>Casuarina cunninghamiana</i>	18	26	14	7	80	2a	2.16	1.88	Retain				
T534	River Oak	<i>Casuarina cunninghamiana</i>	24	34	16	8	80	2a	2.88	2.10	Retain				
T535	River Oak	<i>Casuarina cunninghamiana</i>	24	30	16	8	80	2a	2.88	2.00	Retain				
T536	River Oak	<i>Casuarina cunninghamiana</i>	24	34	14	7	80	2a	2.88	2.10	Retain				
T537	River Oak	<i>Casuarina cunninghamiana</i>	12	18	7	3	90	2a	2.00	1.61	Remove	Dev			
T538	Silky Oak	<i>Grevillea robusta</i>	37	60	18	8	80	2a	4.44	2.67	Remove	Dev			
T539	Radiata Pine	<i>Pinus radiata</i>	48	58	15	9	90	2a	5.76	2.63	Retain				
T540	Radiata Pine	<i>Pinus radiata</i>	74	94	22	12	90	2a	8.88	3.22	Remove	Health			
T541	Dead Stag	Dead Stag	83	93	3	2	0	4a	9.96	3.21	Remove	Dev			
T542	Willow Bottlebrush	<i>Callistemon salignus</i>	58	80	11	11	80	2a	6.93	3.01	Remove	Earthwks			
T543	Liquidambar	<i>Liquidambar styraciflua</i>	36	46	8	7	90	2a	4.32	2.39	Retain				
T544	Yellow Bloodwood	<i>Corymbia eximia</i>	17	23	9	5	90	2a	2.04	1.79	Retain				
T545	Spotted Gum	<i>Corymbia maculata</i>	57	77	23	17	80	2a	6.84	2.97	Retain				
T546	Spotted Gum	<i>Corymbia maculata</i>	38	58	23	12	90	2a	4.56	2.63	Remove	Health			
T547	Spotted Gum	<i>Corymbia maculata</i>	56	80	20	14	70	4c	6.75	3.01	Remove	Health			exposed wood at base, lots kino, borers in trunk
T548	Grey Gum	<i>Eucalyptus punctata</i>	39	49	13	11	65	4c	4.68	2.45	Remove	Dev			bark damage & exposed wood at base, borers in trunk
T549	Red Box	<i>Eucalyptus (polyanthemos?)</i>	37	40	13	12	90	2a	4.44	2.25	Remove	Dev			
T550	Forest Red Gum	<i>Eucalyptus tereticornis</i>	31	43	13	8	90	2a	3.72	2.32	Retain				
T551	Spotted Gum	<i>Corymbia maculata</i>	90	115	19	13	90	2a	10.82	3.51	Retain				small deadwood,
T552	Spotted Gum	<i>Corymbia maculata</i>	90	110	20	15	85	2a	10.80	3.44	Retain				kino
T553	Spotted Gum	<i>Corymbia maculata</i>	43	53	17	10	90	2a	5.16	2.53	Retain				kino, small deadwood
T554	Spotted Gum	<i>Corymbia maculata</i>	53	63	19	11	90	2a	6.36	2.73	Retain				small deadwood
T555	Grey Gum	<i>Eucalyptus punctata</i>	54	62	20	9	90	2a	6.48	2.71	Remove	Health			small deadwood, kino
T556	Forest Red Gum	<i>Eucalyptus tereticornis</i>	33	35	13	5	45	4c	3.96	2.13	Retain				damage cambium, kino, borers, epicormic growth, lots small deadwood
T557	Grey Gum	<i>Eucalyptus punctata</i>	29	32	9	4	85	2c	3.48	2.05	Retain				suppressed above
T558	Spotted Gum	<i>Corymbia maculata</i>	30	35	12	8	80	2a	3.60	2.13	Remove	Health			kino
T559	Forest Red Gum	<i>Eucalyptus tereticornis</i>	20	20	6	2	20	4a	2.40	1.68	Retain				kino, deadwood, low foliage, damage cambium
T560	Forest Red Gum	<i>Eucalyptus tereticornis</i>	31	33	9	4	85	3c	3.72	2.08	Retain				borers, small deadwood
T561	Radiata Pine	<i>Pinus radiata</i>	90	100	19	10	90	2a	10.80	3.31	Retain				medium deadwood
T562	Radiata Pine	<i>Pinus radiata</i>	100	110	19	9	80	2a	12.00	3.44	Retain				medium deadwood, kino
T563	Forest Red Gum	<i>Eucalyptus tereticornis</i>	26	26	14	3	80	3c	3.12	1.88	Retain				small deadwood, broken branch, borers
T564	Radiata Pine	<i>Pinus radiata</i>	98	105	18	8	90	2a	11.76	3.38	Retain				
T565	Radiata Pine	<i>Pinus radiata</i>	96	108	20	13	90	2a	11.52	3.42	Remove	Dev			
T566	Grey Gum	<i>Eucalyptus punctata</i>	46	43	15	8	90	2a	5.47	2.32	Remove	Dev			
T567	Grey Gum	<i>Eucalyptus punctata</i>	26	29	5	2	80	3c	3.12	1.97	Remove	Dev			leaning canopy, kino, small deadwood
T568	Grey Gum	<i>Eucalyptus punctata</i>	41	48	19	8	85	2a	4.92	2.43	Retain				kino
T569	Forest Red Gum	<i>Eucalyptus tereticornis</i>	31	34	13	4	90	2a	3.72	2.10	Retain				
T570	Red Box	<i>Eucalyptus (polyanthemos?)</i>	66	70	18	10	90	2a	7.92	2.85	Retain				small deadwood
T571	Broad-leaved Ironbark	<i>Eucalyptus fibrosa</i>	54	62	18	7	85	2a	6.48	2.71	Retain				epicormic growth, small deadwood
T572	Broad-leaved Ironbark	<i>Eucalyptus fibrosa</i>	76	78	21	11	80	3c	9.12	2.98	Retain				small-medium deadwood, exposed wood, epicormic growth
T573	Broad-leaved Ironbark	<i>Eucalyptus fibrosa</i>	90	98	24	11	80	2c	10.80	3.28	Retain				epicormic growth, small-medium deadwood
T574	Broad-leaved Ironbark	<i>Eucalyptus fibrosa</i>	89	115	27	15	85	2a	10.63	3.51	Retain		V2		small-medium deadwood
T575	Broad-leaved Ironbark	<i>Eucalyptus fibrosa</i>	145	145	25	14	80	3c	17.40	3.87	Retain		V3		borers, epicormic growth, small-medium deadwood
T576	Tallowwood	<i>Eucalyptus microcorys</i>	31	38	19	10	90	2a	3.72	2.20	Remove	Dev			
T577	Red Box	<i>Eucalyptus (polyanthemos?)</i>	56	66	22	13	90	2a	6.72	2.78	Retain				

No 13 Park Road, Wallacia

Tag No.	Common Name	Scientific Name	DBH	BD (cm)	Height (m)	Spread (m)	Vigour (%)	SULE	TPZ Radius (m)	SRZ Radius (m)	Ret/Rem	Reason	Visual Sig	Habitat Tree	Comments
T578	Grey Gum	<i>Eucalyptus punctata</i>	13	18	8	4	70	3a	2.00	1.61	Remove	Dev			exposed wood at 1m, bark damage
T579	Narrow-leaved Ironbark	<i>Eucalyptus crebra</i>	28	32	16	8	80	2a	3.36	2.05	Retain				sparse canopy
T580	Red Box	<i>Eucalyptus (polyanthemus?)</i>	85	76	20	16	80	2a	10.25	2.95	Remove	Dev			
T581	Grey Gum	<i>Eucalyptus punctata</i>	33	43	17	10	80	2a	3.96	2.32	Remove	Dev			bark damage to 2m, kino
T582	Grey Gum	<i>Eucalyptus punctata</i>	38	44	11	11	80	2a	4.56	2.34	Remove	Dev			
T583	Rough-barked Apple	<i>Angophora floribunda</i>	42	62	23	11	80	2a	5.04	2.71	Remove	Dev			slightly stressed, 'clumpy' canopy
T584	Eucalyptus sp.	<i>Eucalyptus sp.</i>	58	70	22	14	90	2a	6.99	2.85	Retain				
T585	Red Box	<i>Eucalyptus (polyanthemus?)</i>	59	67	20	12	90	2a	7.03	2.80	Retain				
T586	Narrow-leaved Ironbark	<i>Eucalyptus crebra</i>	31	36	13	8	80	2a	3.72	2.15	Retain				sparse canopy
T587	Grey Gum	<i>Eucalyptus punctata</i>	36	43	13	9	80	2a	4.32	2.32	Retain				
T588	Broad-leaved Ironbark	<i>Eucalyptus fibrosa</i>	88	98	23	15	80	2a	10.56	3.28	Remove	Dev	V2		
T589	Grey Gum	<i>Eucalyptus punctata</i>	17	23	5	4	80	2a	2.04	1.79	Remove	Dev			
T590	Grey Gum	<i>Eucalyptus punctata</i>	38	45	11	13	90	2a	4.56	2.37	Retain				
T591	Broad-leaved Ironbark	<i>Eucalyptus fibrosa</i>	73	120	25	12	80	2a	8.79	3.57	Retain				crowded
T592	Broad-leaved Ironbark	<i>Eucalyptus fibrosa</i>	46	66	24	13	80	2a	5.52	2.78	Retain				crowded
T593	Broad-leaved Ironbark	<i>Eucalyptus fibrosa</i>	44	57	23	13	80	2a	5.28	2.61	Retain				crowded
T594	Broad-leaved Ironbark	<i>Eucalyptus fibrosa</i>	68	78	25	15	80	2a	8.16	2.98	Retain		V2		crowded
T595	Broad-leaved Ironbark	<i>Eucalyptus fibrosa</i>	49	64	19	6	75	3c	5.88	2.74	Remove	Dev			medium deadwood, epicormic growth, exposed wood
T596	Radiata Pine	<i>Pinus radiata</i>	44	64	13	11	80	2a	5.28	2.74	Remove	Dev			
T597	Radiata Pine	<i>Pinus radiata</i>	52	58	10	7	80	3c	6.24	2.63	Remove	Dev			kino, multiple loppings, leaning canopy
T598	Radiata Pine	<i>Pinus radiata</i>	68	76	19	14	80	2a	8.16	2.95	Remove	Health			
T599	Radiata Pine	<i>Pinus radiata</i>	70	75	13	8	45	4a	8.40	2.93	Retain				kino, multiple loppings, dying foliage, medium deadwood
T600	Radiata Pine	<i>Pinus radiata</i>	67	87	22	13	80	2a	8.04	3.12	Retain		V3		multiple loppings, lots kino
T601	River Oak	<i>Casuarina cunninghamiana</i>	20	26	11	3	85	2a	2.40	1.88	Retain				small deadwood
T602	River Oak	<i>Casuarina cunninghamiana</i>	23	28	11	5	90	2a	2.76	1.94	Retain				
T603	River Oak	<i>Casuarina cunninghamiana</i>	13	15	8	3	70	3c	2.00	1.49	Retain				low foliage, crowded, suppressed above
T604	River Oak	<i>Casuarina cunninghamiana</i>	21	28	10	4	80	3c	2.52	1.94	Retain				leaning canopy, small deadwood
T605	River Oak	<i>Casuarina cunninghamiana</i>	22	24	9	3	80	3c	2.64	1.82	Retain				medium broken branch, small deadwood, suppressed above
T606	River Oak	<i>Casuarina cunninghamiana</i>	15	16	6	3	85	2a	2.00	1.53	Retain				small deadwood
T607	River Oak	<i>Casuarina cunninghamiana</i>	20	21	9	3	85	2a	2.40	1.72	Retain				small deadwood
T608	River Oak	<i>Casuarina cunninghamiana</i>	16	17	9	3	70	3c	2.00	1.57	Retain				damage cambium, small deadwood, crowded
T609	River Oak	<i>Casuarina cunninghamiana</i>	18	20	10	3	70	3c	2.16	1.68	Retain				borers, lots small deadwood, exposed wood
T610	River Oak	<i>Casuarina cunninghamiana</i>	19	19	9	4	85	2a	2.28	1.65	Retain				small deadwood
T611	River Oak	<i>Casuarina cunninghamiana</i>	24	22	11	4	90	2a	2.88	1.75	Retain				small deadwood
T612	Black Wattle	<i>Acacia decurrens</i>	12	12	9	2	50	3a	2.00	1.36	Retain				suppressed above, lots small deadwood, kino, dying foliage
T613	River Oak	<i>Casuarina cunninghamiana</i>	25	27	9	4	85	2a	3.00	1.91	Retain				small deadwood
T614	River Oak	<i>Casuarina cunninghamiana</i>	30	31	12	5	90	2a	3.60	2.02	Retain				small deadwood
T615	River Oak	<i>Casuarina cunninghamiana</i>	21	22	9	4	90	2a	2.52	1.75	Retain				small deadwood
T616	Grey Box	<i>Eucalyptus moluccana</i>	67	73	20	15	70	3c	8.04	2.90	Retain				epicormic growth, lots small-medium deadwood,
T617	River Oak	<i>Casuarina cunninghamiana</i>	39	38	11	6	75	3c	4.67	2.20	Retain				suppressed above, leaning canopy
T618	River Oak	<i>Casuarina cunninghamiana</i>	24	27	9	3	80	2c	2.88	1.91	Retain				suppressed above
T619	River Oak	<i>Casuarina cunninghamiana</i>	26	28	7	3	90	2c	3.12	1.94	Retain				leaning canopy
T620	River Oak	<i>Casuarina cunninghamiana</i>	21	23	8	4	85	3c	2.52	1.79	Retain				suppressed above, leaning canopy
T621	Forest Red Gum	<i>Eucalyptus tereticornis</i>	54	60	20	10	80	2c	6.51	2.67	Retain				small-medium deadwood,kino,suppressed below
T622	Forest Red Gum	<i>Eucalyptus tereticornis</i>	107	137	24	17	85	2a	12.84	3.78	Retain		V2		small-large deadwood, kino

No 13 Park Road, Wallacia

Tag No.	Common Name	Scientific Name	DBH	BD (cm)	Height (m)	Spread (m)	Vigour (%)	SULE	TPZ Radius (m)	SRZ Radius (m)	Ret/Rem	Reason	Visual Sig	Habitat Tree	Comments
T623	Thin-leaved Stringybark	<i>Eucalyptus eugenioides</i>	39	40	16	10	80	2a	4.68	2.25	Retain				small deadwood
T624	Prickly-leaved Tea Tree	<i>Melaleuca stypheloides</i>	65	75	9	8	90	2a	7.80	2.93	Retain				suppressed above
T625	Forest Red Gum	<i>Eucalyptus tereticornis</i>	26	28	11	5	70	2c	3.12	1.94	Retain				leaning canopy, small-medium deadwood
T626	Thin-leaved Stringybark	<i>Eucalyptus eugenioides</i>	40	43	19	12	90	2a	4.80	2.32	Remove	Dev			medium deadwood
T627	Forest Red Gum	<i>Eucalyptus tereticornis</i>	37	45	18	8	80	2c	4.44	2.37	Remove	Health			leaning canopy, lots small-medium deadwood
T628	Forest Red Gum	<i>Eucalyptus tereticornis</i>	53	59	22	9	40	4c	6.36	2.65	Remove	Dev			damage cambium, borers, large deadwood ,kino
T629	Grey Gum	<i>Eucalyptus punctata</i>	12	17	5	2	90	2a	2.00	1.57	Remove	Dev			
T630	Grey Gum	<i>Eucalyptus punctata</i>	13	15	8	2	90	2a	2.00	1.49	Remove	Dev			
T631	Forest Red Gum	<i>Eucalyptus tereticornis</i>	180	210	26	15	70	4c	21.60	4.52	Remove	Dev	V2		damage cambium, kino, small-large deadwood, borers, epicormic growth
T632	Grey Gum	<i>Eucalyptus punctata</i>	15	17	8	2	90	2a	2.00	1.57	Remove	Dev			
T633	Grey Gum	<i>Eucalyptus punctata</i>	13	15	6	2	90	2a	2.00	1.49	Remove	Dev			
T634	Grey Gum	<i>Eucalyptus punctata</i>	19	23	10	3	90	2a	2.28	1.79	Retain				
T635	Grey Gum	<i>Eucalyptus punctata</i>	22	24	10	4	90	2a	2.64	1.82	Retain				
T636	Forest Red Gum	<i>Eucalyptus tereticornis</i>	25	29	18	7	85	2a	3.00	1.97	Retain				small-medium deadwood
T637	Prickly-leaved Tea Tree	<i>Melaleuca stypheloides</i>	31	48	15	5	85	2a	3.72	2.43	Retain				
T638	Prickly-leaved Tea Tree	<i>Melaleuca stypheloides</i>	28	34	8	4	70	2c	3.36	2.10	Retain				crowded, suppressed above
T639	Prickly-leaved Tea Tree	<i>Melaleuca stypheloides</i>	13	16	4	1	80	3c	2.00	1.53	Remove	Health			suppressed above, small deadwood
T640	Forest Red Gum	<i>Eucalyptus tereticornis</i>	130	150	24	18	65	4c	15.60	3.92	Remove	Health	V2		exposed wood, damage cambium, heavily leaning canopy, medium deadwood
T641	Forest Red Gum	<i>Eucalyptus tereticornis</i>	133	158	25	12	65	4c	15.96	4.01	Remove	Health			exposed wood along main trunk, medium deadwood
T642	Thin-leaved Stringybark	<i>Eucalyptus eugenoides</i>	57	60	19	13	80	4c	6.84	2.67	Remove	Health			exposed wood @ base, borers, small-medium deadwood, bracket fungi, leaning canopy
T643	Forest Red Gum	<i>Eucalyptus tereticornis</i>	22	26	9	5	70	4c	2.64	1.88	Retain				exposed wood, small deadwood, suppressed above
T644	Forest Red Gum	<i>Eucalyptus tereticornis</i>	15	18	9	2	70	3c	2.00	1.61	Retain				small deadwood, kino
T645	Forest Red Gum	<i>Eucalyptus tereticornis</i>	25	34	14	4	70	3c	3.00	2.10	Retain				lots small deadwood, kink in trunk, leaning canopy
T646	Forest Red Gum	<i>Eucalyptus tereticornis</i>	22	28	5	2	80	2a	2.63	1.94	Remove	Dev			
T647	Thin-leaved Stringybark	<i>Eucalyptus eugenoides</i>	43	48	14	7	85	2a	5.16	2.43	Remove	Dev			small deadwood
T648	Thin-leaved Stringybark	<i>Eucalyptus eugenoides</i>	61	75	15	6	75	4c	7.32	2.93	Remove	Dev			large broken trunk, epicormic growth, damage cambium
T649	Thin-leaved Stringybark	<i>Eucalyptus eugenoides</i>	47	52	6	3	60	4c	5.64	2.51	Remove	Health			large broken trunk
T650	Thin-leaved Stringybark	<i>Eucalyptus eugenoides</i>	29	32	9	4	65	4c	3.48	2.05	Retain				large broken trunk, exposed wood
T651	River Oak	<i>Casuarina cunninghamiana</i>	26	38	12	8	90	2a	3.12	2.20	Retain				
T652	Forest Red Gum	<i>Eucalyptus tereticornis</i>	52	50	20	11	80	2a	6.28	2.47	Retain				2x trunks at 0.5m
T653	River Oak	<i>Casuarina cunninghamiana</i>	12	21	9	4	90	2a	2.00	1.72	Retain				
T654	River Oak	<i>Casuarina cunninghamiana</i>	26	37	12	7	90	2a	3.14	2.18	Retain				
T655	River Oak	<i>Casuarina cunninghamiana</i>	20	26	12	4	90	2a	2.40	1.88	Retain				
T656	River Oak	<i>Casuarina cunninghamiana</i>	23	33	12	6	80	2a	2.76	2.08	Remove	Health			
T657	Dead Stag	Dead Stag	16	23	8	3	0	4a	2.00	1.79	Retain				
T658	River Oak	<i>Casuarina cunninghamiana</i>	26	29	12	8	80	2a	3.15	1.97	Retain				
T659	River Oak	<i>Casuarina cunninghamiana</i>	21	29	12	5	80	2a	2.46	1.97	Remove	Dev			
T660	River Oak	<i>Casuarina cunninghamiana</i>	18	24	9	5	80	2a	2.16	1.82	Remove	Dev			
T661	Grey Box	<i>Eucalyptus moluccana</i>	13	19	8	3	90	2a	2.00	1.65	Remove	Dev			
T662	River Oak	<i>Casuarina cunninghamiana</i>	18	30	7	5	80	2a	2.14	2.00	Retain				
T663	River Oak	<i>Casuarina cunninghamiana</i>	10	16	7	4	80	2a	2.00	1.53	Retain				
T664	River Oak	<i>Casuarina cunninghamiana</i>	17	23	10	4	80	2a	2.04	1.79	Retain				medium deadwood

No 13 Park Road, Wallacia

Tag No.	Common Name	Scientific Name	DBH	BD (cm)	Height (m)	Spread (m)	Vigour (%)	SULE	TPZ Radius (m)	SRZ Radius (m)	Ret/Rem	Reason	Visual Sig	Habitat Tree	Comments
T665	River Oak	<i>Casuarina cunninghamiana</i>	20	29	13	6	90	2a	2.40	1.97	Retain				
T666	River Oak	<i>Casuarina cunninghamiana</i>	19	27	10	4	90	2a	2.28	1.91	Retain				
T667	River Oak	<i>Casuarina cunninghamiana</i>	21	28	10	5	90	2a	2.52	1.94	Retain				
T668	River Oak	<i>Casuarina cunninghamiana</i>	21	28	12	5	90	2a	2.52	1.94	Retain				
T669	River Oak	<i>Casuarina cunninghamiana</i>	18	24	11	7	80	2a	2.12	1.82	Retain				2x trunks at 0.7m
T670	River Oak	<i>Casuarina cunninghamiana</i>	17	28	11	4	80	2a	2.06	1.94	Retain				2x trunks at 0.7m
T671	River Oak	<i>Casuarina cunninghamiana</i>	20	29	10	5	80	2a	2.38	1.97	Retain				2x trunks at 0.2m
T672	River Oak	<i>Casuarina cunninghamiana</i>	27	34	12	7	75	3a	3.25	2.10	Retain				4x trunks at 0.5m
T673	Forest Red Gum	<i>Eucalyptus tereticornis</i>	72	82	24	16	65	3d	8.64	3.04	Retain		V2		exposed wood 1-3m, fungal attack
T674	Two-veined Hickory	<i>Acacia binervata</i>	25	32	8	7	80	3a	2.98	2.05	Retain				
T675	Thin-leaved Stringybark	<i>Eucalyptus eugenioides</i>	45	49	15	7	70	3c	5.40	2.45	Remove	Health			stressed, epicormic growth, crowded, canopy off centre
T676	Forest Red Gum	<i>Eucalyptus tereticornis</i>	96	105	25	14	65	4c	11.52	3.38	Retain		V3		overmature, lge & v. lge deadwood
T677	Thin-leaved Stringybark	<i>Eucalyptus eugenioides</i>	29	33	15	10	80	2a	3.48	2.08	Retain				some epicormic growth
T678	Forest Red Gum	<i>Eucalyptus tereticornis</i>	82	90	24	15	80	2a	9.84	3.17	Retain		V2		
T679	Grey Box	<i>Eucalyptus moluccana</i>	20	25	18	7	90	2a	2.40	1.85	Remove	Health			
T680	White Mahogany	<i>Eucalyptus acmenoides</i>	24	28	7	10	70	4c	2.88	1.94	Retain				leaning >15deg, canopy off centre, poor form
T681	Rough-barked Apple	<i>Angophora floribunda</i>	48	68	18	8	70	3c	5.76	2.81	Retain				stressed, epicormic growth, crowded, suppressed
T682	White Mahogany	<i>Eucalyptus acmenoides</i>	40	37	18	12	75	3c	4.84	2.18	Retain				2x trunks at 1m, lots small deadwood, epicormic growth
T683	Rough-barked Apple	<i>Angophora floribunda</i>	39	43	19	9	75	3c	4.68	2.32	Retain				stressed, epicormic growth, leaning 10deg, canopy off centre
T684	Grey Gum	<i>Eucalyptus punctata</i>	12	17	11	4	80	2a	2.00	1.57	Retain				
T685	Prickly-leaved Tea Tree	<i>Melaleuca stypheloides</i>	11	14	6	4	90	2a	2.00	1.45	Retain				
T686	Prickly-leaved Tea Tree	<i>Melaleuca stypheloides</i>	19	23	15	4	80	2a	2.28	1.79	Retain				crowded
T687	Prickly-leaved Tea Tree	<i>Melaleuca stypheloides</i>	37	55	13	7	90	2a	4.41	2.57	Retain				
T688	Prickly-leaved Tea Tree	<i>Melaleuca stypheloides</i>	14	21	10	3	90	2a	2.00	1.72	Retain				
T689	Prickly-leaved Tea Tree	<i>Melaleuca stypheloides</i>	13	16	10	3	90	2a	2.00	1.53	Retain				
T690	Prickly-leaved Tea Tree	<i>Melaleuca stypheloides</i>	17	25	4	2	60	2c	2.00	1.85	Retain				larger trunk broken at 1.5m
T691	Prickly-leaved Tea Tree	<i>Melaleuca stypheloides</i>	10	14	5	2	90	2a	2.00	1.45	Retain				
T692	Prickly-leaved Tea Tree	<i>Melaleuca stypheloides</i>	16	22	7	3	90	2a	2.00	1.75	Retain				
T693	Forest Red Gum	<i>Eucalyptus tereticornis</i>	22	25	13	11	90	2a	2.64	1.85	Retain				
T694	Forest Red Gum	<i>Eucalyptus tereticornis</i>	14	18	9	3	90	2a	2.00	1.61	Retain				
T695	Forest Red Gum	<i>Eucalyptus tereticornis</i>	26	29	15	9	80	2a	3.12	1.97	Retain				crowded
T696	Grey Box	<i>Eucalyptus moluccana</i>	24	28	17	9	90	2a	2.88	1.94	Retain				crowded
T697	Forest Red Gum	<i>Eucalyptus tereticornis</i>	20	26	9	7	80	2a	2.40	1.88	Retain				crowded, poor form
T698	Forest Red Gum	<i>Eucalyptus tereticornis</i>	24	33	12	5	80	2a	2.88	2.08	Remove	Health			crowded
T699	White Mahogany	<i>Eucalyptus acmenoides</i>	28	33	17	8	20	4a	3.36	2.08	Retain				declining, epicormic growth on trunk to 2m, remainder of tree is dead
T700	Grey Box	<i>Eucalyptus moluccana</i>	31	38	22	9	80	2a	3.72	2.20	Remove	Health			
T701	Thin-leaved Stringybark	<i>Eucalyptus eugenioides</i>	21	30	9	5	70	3c	2.55	2.00	Remove	Dev			suppressed above
T702	Forest Red Gum	<i>Eucalyptus tereticornis</i>	58	90	23	12	75	2c	7.00	3.17	Retain				small deadwood, epicormic growth
T703	Forest Red Gum	<i>Eucalyptus tereticornis</i>	98	110	24	14	70	2c	11.76	3.44	Retain		V3	Cat-3	epicormic growth, lots small deadwood
T704	Thin-leaved Stringybark	<i>Eucalyptus eugenioides</i>	80	95	22	12	85	2a	9.60	3.24	Retain				medium broken branch, small deadwood
T705	Forest Red Gum	<i>Eucalyptus tereticornis</i>	110	130	26	15	70	2c	13.20	3.69	Remove	Health	V2		lots small deadwood, epicormic growth,
T706	Dead Stag	Dead Stag	24	29	9	3	0	4a	2.88	1.97	Retain				
T707	Grey Box	<i>Eucalyptus moluccana</i>	114	150	25	16	65	3c	13.68	3.92	Remove	Health	V2	Cat-3	epicormic growth, lots small deadwood
T708	Dead Stag	Dead Stag	23	23	7	2	0	4a	2.76	1.79	Remove	Dev			
T709	Forest Red Gum	<i>Eucalyptus tereticornis</i>	73	76	23	13	70	2c	8.76	2.95	Retain		V3		lots small deadwood, leaning canopy, epicormic growth

No 13 Park Road, Wallacia

Tag No.	Common Name	Scientific Name	DBH	BD (cm)	Height (m)	Spread (m)	Vigour (%)	SULE	TPZ Radius (m)	SRZ Radius (m)	Ret/Rem	Reason	Visual Sig	Habitat Tree	Comments
T710	Forest Red Gum	<i>Eucalyptus tereticornis</i>	45	50	21	8	65	3a	5.40	2.47	Remove	Health			epicormic growth, small deadwood, leaning canopy
T711	Forest Red Gum	<i>Eucalyptus tereticornis</i>	43	60	19	7	30	4a	5.19	2.67	Remove	Health			1xtrunk dead, 1xtrunk with epicormic growth, lots small deadwood, bracket fungi
T712	Forest Red Gum	<i>Eucalyptus tereticornis</i>	24	26	19	3	20	4a	2.88	1.88	Remove	Health			stressed, epicormic growth, small deadwood
T713	Forest Red Gum	<i>Eucalyptus tereticornis</i>	50	60	23	7	25	4a	6.00	2.67	Remove	Health			dying canopy, small deadwood
T714	Forest Red Gum	<i>Eucalyptus tereticornis</i>	27	30	17	4	20	4a	3.24	2.00	Remove	Health			dying canopy, epicormic growth, lots small deadwood
T715	Forest Red Gum	<i>Eucalyptus tereticornis</i>	26	30	18	4	20	4a	3.12	2.00	Remove	Health			stressed, dying canopy
T716	Forest Red Gum	<i>Eucalyptus tereticornis</i>	33	40	17	10	50	3b	3.96	2.25	Remove	Health			heavily leaning canopy, small deadwood, epicormic growth
T717	Dead Stag	Dead Stag	55	68	23	10	0	4a	6.60	2.81	Remove	Health			dead canopy, lots of deadwood
T718	Dead Stag	Dead Stag	32	38	23	5	0	4a	3.84	2.20	Remove	Health			
T719	Dead Stag	Dead Stag	27	33	17	3	0	4a	3.24	2.08	Remove	Health			
T720	Dead Stag	Dead Stag	34	43	21	5	0	4a	4.08	2.32	Remove	Health			
T721	Dead Stag	Dead Stag	21	21	16	3	0	4a	2.52	1.72	Remove	Health			
T722	Dead Stag	Dead Stag	14	14	9	2	0	4a	2.00	1.45	Remove	Health			
T723	Dead Stag	Dead Stag	36	40	22	3	0	4a	4.32	2.25	Remove	Health			
T724	Dead Stag	Dead Stag	52	54	23	7	0	4a	6.24	2.55	Remove	Health			
T725	Forest Red Gum	<i>Eucalyptus tereticornis</i>	23	22	11	3	30	4c	2.76	1.75	Remove	Health			exposed wood, leaning, lots small deadwood, epicormic growth
T726	Forest Red Gum	<i>Eucalyptus tereticornis</i>	29	39	21	6	45	4a	3.48	2.23	Retain				lots of deadwood, epicormic growth, reduced canopy
T727	Forest Red Gum	<i>Eucalyptus tereticornis</i>	22	22	13	6	70	3b	2.64	1.75	Remove	Health			exposed wood, leaning canopy ,epicormic growth
T728	Dead Stag	Dead Stag	19	22	13	2	0	4a	2.28	1.75	Remove	Health			
T729	Dead Stag	Dead Stag	70	70	23	11	0	4a	8.40	2.85	Remove	Health			
T730	Dead Stag	Dead Stag	62	62	24	7	0	4a	7.44	2.71	Retain				
T731	Forest Red Gum	<i>Eucalyptus tereticornis</i>	52	64	25	13	25	3b	6.24	2.74	Retain				lots of deadwood, dying canopy, epicormic growth below
T732	Forest Red Gum	<i>Eucalyptus tereticornis</i>	25	30	14	6	75	3c	3.00	2.00	Remove	Health		Cat-3	small deadwood, epicormic growth
T733	Dead Stag	Dead Stag	22	22	12	0	0	4a	2.64	1.75	Remove	Health			
T734	Forest Red Gum	<i>Eucalyptus tereticornis</i>	32	33	22	5	20	4a	3.84	2.08	Remove	Health			dead canopy, epicormic growth, deadwood
T735	Forest Red Gum	<i>Eucalyptus tereticornis</i>	52	63	24	8	15	4a	6.24	2.73	Retain				dying & leaning canopy, deadwood, epicormic growth
T736	Forest Red Gum	<i>Eucalyptus tereticornis</i>	55	60	24	10	60	3b	6.60	2.67	Remove	Health			leaning canopy, small-medium deadwood, epicormic growth, canopy dying
T737	Dead Stag	Dead Stag	80	90	24	13	0	4a	9.60	3.17	Remove	Health	V3		
T738	Forest Red Gum	<i>Eucalyptus tereticornis</i>	60	68	24	10	40	4a	7.20	2.81	Retain				leaning canopy, epicormic growth, deadwood, low foliage
T739	Grey Box	<i>Eucalyptus moluccana</i>	120	140	24	14	75	2d	14.40	3.81	Retain		V3		small-medium deadwood, epicormic growth
T740	Radiata Pine	<i>Pinus radiata</i>	63	68	16	6	80	3c	7.56	2.81	Retain				kino, borers in loppings, small deadwood
T741	Forest Red Gum	<i>Eucalyptus tereticornis</i>	27	35	9	6	75	2a	3.24	2.13	Retain				kino
T742	Spotted Gum	<i>Corymbia maculata</i>	140	140	22	13	90	2a	16.80	3.81	Retain		V3		
T743	Liquidambar	<i>Liquidambar styraciflua</i>	36	47	9	3	90	2a	4.32	2.41	Remove	Health			small deadwood
T744	Forest Red Gum	<i>Eucalyptus tereticornis</i>	110	100	15	9	80	4c	13.20	3.31	Retain				exposed wood, borers, small-medium deadwood, epicormic growth
T745	Liquidambar	<i>Liquidambar styraciflua</i>	27	30	6	2	90	2a	3.20	2.00	Retain				
T746	Spotted Gum	<i>Corymbia maculata</i>	91	95	22	12	85	2a	10.92	3.24	Remove	Health			kino, small deadwood
T747	Spotted Gum	<i>Corymbia maculata</i>	39	45	23	4	65	4c	4.68	2.37	Retain				exposed wood, borers, kino, small deadwood, narrow canopy, crowded
T748	Radiata Pine	<i>Pinus radiata</i>	58	65	13	5	50	3c	6.96	2.76	Remove	Earthworks			suppressed above, kino, lots small deadwood
T749	Radiata Pine	<i>Pinus radiata</i>	98	98	21	16	70	3c	11.76	3.28	Retain		V2		lots small-medium deadwood, kino, borers
T750	Spotted Gum	<i>Corymbia maculata</i>	58	64	22	12	85	2a	6.96	2.74	Retain				kino, small deadwood
T751	Forest Red Gum	<i>Eucalyptus tereticornis</i>	39	44	20	8	75	3c	4.68	2.34	Retain				bar damage at 1m, lots kino, small deadwood

No 13 Park Road, Wallacia

Tag No.	Common Name	Scientific Name	DBH	BD (cm)	Height (m)	Spread (m)	Vigour (%)	SULE	TPZ Radius (m)	SRZ Radius (m)	Ret/Rem	Reason	Visual Sig	Habitat Tree	Comments
T752	Forest Red Gum	<i>Eucalyptus tereticornis</i>	17	24	5	5	50	3c	2.06	1.82	Remove	Health			2x trunks at 0m, very twisted & poor form, epicormic growth
T753	Grey Box	<i>Eucalyptus moluccana</i>	47	54	21	11	70	3c	5.64	2.55	Remove	Health			stressed, lots epicormic growth, small deadwood
T754	Grey Box	<i>Eucalyptus moluccana</i>	75	95	26	16	50	4a	9.00	3.24	Retain		V2		declining, v sparse canopy, lots epicormic growth, lots small & med deadwood
T755	Forest Red Gum	<i>Eucalyptus tereticornis</i>	32	36	16	8	80	2a	3.84	2.15	Retain				small deadwood
T756	Forest Red Gum	<i>Eucalyptus tereticornis</i>	32	40	19	7	80	2a	3.84	2.25	Retain				small deadwood
T757	Forest Red Gum	<i>Eucalyptus tereticornis</i>	17	26	8	6	70	3a	2.04	1.88	Remove	Health			crowded, suppressed, small deadwood, canopy off centre
T758	Two-veined Hickory	<i>Acacia binervata</i>	22	24	7	7	80	4c	2.65	1.82	Retain				borers in all 3 trunks
T759	Thin-leaved Stringybark	<i>Eucalyptus eugenoides</i>	27	31	11	11	80	2a	3.24	2.02	Retain				
T760	Thin-leaved Stringybark	<i>Eucalyptus eugenoides</i>	35	43	22	8	70	3c	4.20	2.32	Remove	Health			stressed, epicormic growth, lots small deadwood
T761	Forest Red Gum	<i>Eucalyptus tereticornis</i>	13	21	5	3	70	4c	2.00	1.72	Retain				crowded, suppressed, canopy off centre exposed wood at 0.3m
T762	Grey Box	<i>Eucalyptus moluccana</i>	65	75	24	14	75	3a	7.80	2.93	Retain		V3		lots med & small deadwood, some epicormic growth, sparse canopy
T763	Grey Box	<i>Eucalyptus moluccana</i>	53	76	24	14	65	3a	6.36	2.95	Retain				sparse canopy, some epicormic growth, lots small & med deadwood
T764	Forest Red Gum	<i>Eucalyptus tereticornis</i>	58	68	20	8	65	3a	6.96	2.81	Remove	Health		Cat-3	lots epicormic growth, sparse canopy, small deadwood
T765	Dead Stag	Dead Stag	43	63	25	8	0	4a	5.16	2.73	Retain				
T766	Forest Red Gum	<i>Eucalyptus tereticornis</i>	20	23	8	4	45	3c	2.40	1.79	Remove	Health		Cat-3	crowded, suppressed, sparse canopy, epicormic growth
T767	Dead Stag	Dead Stag	23	36	8	7	0	4a	2.76	2.15	Remove	Health			
T768	Dead Stag	Dead Stag	34	44	22	7	0	4a	4.08	2.34	Retain				
T769	Forest Red Gum	<i>Eucalyptus tereticornis</i>	44	60	20	8	30	3b	5.26	2.67	Retain				
T770	Forest Red Gum	<i>Eucalyptus tereticornis</i>	23	33	15	8	60	3a	2.76	2.08	Retain				crowded, suppressed, leaning, canopy off centre
T771	Forest Red Gum	<i>Eucalyptus tereticornis</i>	17	23	5	2	50	3b	2.04	1.79	Retain				bark damage & exposed wood 0-3m, main trunk dead above 2m
T772	Forest Red Gum	<i>Eucalyptus tereticornis</i>	17	24	6	4	45	3b	2.06	1.82	Remove	Health			larger trunk dead, bark damage 0-3m, exposed wood, borers in trunk
T773	Dead Stag	Dead Stag	24	30	6	2	0	4a	2.88	2.00	Remove	Health			
T774	Dead Stag	Dead Stag	12	15	8	1	0	4a	2.00	1.49	Retain				
T775	Forest Red Gum	<i>Eucalyptus tereticornis</i>	43	53	22	7	45	3b	5.16	2.53	Remove	Health			crowded, suppressed, leaning, canopy off centre, epicormic growth, 45% canopy
T776	Dead Stag	Dead Stag	28	32	21	3	0	4a	3.36	2.05	Remove	Health			
T777	Dead Stag	Dead Stag	39	43	23	7	0	4a	4.68	2.32	Remove	Health			
T778	Dead Stag	Dead Stag	36	39	24	5	0	4a	4.32	2.23	Remove	Health		Cat-3	
T779	Dead Stag	Dead Stag	39	49	25	6	0	4a	4.68	2.45	Remove	Health			
T780	Dead Stag	Dead Stag	21	25	8	3	0	4a	2.52	1.85	Remove	Health			
T781	Forest Red Gum	<i>Eucalyptus tereticornis</i>	63	80	25	12	40	4c	7.56	3.01	Remove	Health			30% canopy left, epicormic growth, stressed, exposed wood at 1.3m, borers in trunk
T782	Forest Red Gum	<i>Eucalyptus tereticornis</i>	22	31	19	5	35	3b	2.64	2.02	Remove	Health			25% canopy left, epicormic growth, termite mound at base
T783	Grey Box	<i>Eucalyptus moluccana</i>	46	50	25	7	35	4c	5.52	2.47	Remove	Health			30% canopy left, stressed, epicormic growth, exposed wood at base, fungal attack
T784	Forest Red Gum	<i>Eucalyptus tereticornis</i>	30	36	21	3	20	4c	3.60	2.15	Retain			Cat-3	bark damage 0-3m, exposed wood, fungal attack, borers in trunk
T785	Grey Box	<i>Eucalyptus moluccana</i>	33	36	20	6	30	3d	3.96	2.15	Remove	Health			30% canopy left, epicormic growth, small deadwood
T786	Forest Red Gum	<i>Eucalyptus tereticornis</i>	35	43	24	5	30	4c	4.20	2.32	Remove	Health			bark damage 0-3m, exposed wood, thin canopy, epicormic growth
T787	Dead Stag	Dead Stag	17	23	5	4	0	4a	2.04	1.79	Remove	Health			
T788	Forest Red Gum	<i>Eucalyptus tereticornis</i>	64	84	2r	9	30	4a	7.68	3.08	Retain				crowded, canopy off centre, epicormic growth, 25% canopy left
T789	Grey Box	<i>Eucalyptus moluccana</i>	55	75	24	11	50	2a	6.60	2.93	Remove	Dev			50% canopy left, lots epicormic growth, exposed wood on major root, lots small & med deadwood
T790	Grey Box	<i>Eucalyptus moluccana</i>	54	64	24	14	70	2a	6.48	2.74	Retain				lots small & med deadwood, sparse canopy
T791	Radiata Pine	<i>Pinus radiata</i>	42	49	14	8	80	2a	5.04	2.45	Retain				
T792	Bunya Pine	<i>Araucaria bidwilli</i>	55	65	19	12	90	2a	6.60	2.76	Retain				

No 13 Park Road, Wallacia

Tag No.	Common Name	Scientific Name	DBH	BD (cm)	Height (m)	Spread (m)	Vigour (%)	SULE	TPZ Radius (m)	SRZ Radius (m)	Ret/Rem	Reason	Visual Sig	Habitat Tree	Comments
T793	a Cypress Pine	<i>Callitris sp.</i>	42	48	9	8	90	2a	5.04	2.43	Retain				
T794	Spotted Gum	<i>Corymbia maculata</i>	65	85	19	16	80	2a	7.80	3.09	Retain				bark damage at base, exposed wood, lots kino
T795	Spotted Gum	<i>Corymbia maculata</i>	87	107	17	15	80	2a	10.44	3.40	Retain				bark damage & exposed wood at base, kino
T796	Radiata Pine	<i>Pinus radiata</i>	44	64	9	10	80	2a	5.28	2.74	Retain				
T797	Willow Bottlebrush	<i>Callistemon salignus</i>	40	58	10	6	80	2a	4.74	2.63	Remove	Health			
T798	Dead Stag	Dead Stag	40	55	9	7	0	4a	4.80	2.57	Remove	Health			
T799	Radiata Pine	<i>Pinus radiata</i>	80	110	17	14	80	2a	9.60	3.44	Retain				
T800	Radiata Pine	<i>Pinus radiata</i>	42	47	20	9	80	2a	5.09	2.41	Retain				
T801	Spotted Gum	<i>Corymbia maculata</i>	41	54	22	11	80	2a	4.92	2.55	Retain				kino, sml deadwood
T802	Spotted Gum	<i>Corymbia maculata</i>	85	92	24	16	85	2a	10.20	3.20	Retain		V2		kino, broken branches
T803	Spotted Gum	<i>Corymbia maculata</i>	62	68	23	14	90	2a	7.44	2.81	Retain		V3		
T804	Radiata Pine	<i>Pinus radiata</i>	60	60	23	5	70	3c	7.20	2.67	Retain				multiple loppings, kino, borers
T805	Spotted Gum	<i>Corymbia maculata</i>	100	115	25	17	90	2a	12.00	3.51	Retain		V2		
T806	Spotted Gum	<i>Corymbia maculata</i>	68	73	23	16	90	2a	8.16	2.90	Retain		V2		
T807	Radiata Pine	<i>Pinus radiata</i>	90	105	24	12	85	2a	10.80	3.38	Retain				loppings, kino, small deadwood
T808	Radiata Pine	<i>Pinus radiata</i>	120	130	24	12	90	2a	14.40	3.69	Remove	Drainage			
T809	Radiata Pine	<i>Pinus radiata</i>	75	87	22	8	80	2a	9.00	3.12	Remove	Drainage			multiple loppings, small deadwood, kino
T810	Forest Red Gum	<i>Eucalyptus tereticornis</i>	30	32	12	3	85	2a	3.60	2.05	Remove	Health			small deadwood
T811	Radiata Pine	<i>Pinus radiata</i>	102	120	22	10	35	4a	12.24	3.57	Retain				multiple loppings, kino, exposed wood, dying canopy, small-medium deadwood
T812	Radiata Pine	<i>Pinus radiata</i>	61	68	23	10	55	3a	7.32	2.81	Retain				multiple loppings, kino, dying canopy, borers
T813	Forest Red Gum	<i>Eucalyptus tereticornis</i>	13	13	5	2	80	2a	2.00	1.40	Remove	Golf Cse			small deadwood
T814	Tallowwood	<i>Eucalyptus microcorys</i>	80	88	23	11	85	2a	9.60	3.14	Retain				small deadwood & broken branch
T815	River Oak	<i>Casuarina cunninghamiana</i>	64	85	23	6	90	2a	7.68	3.09	Retain				
T816	River Oak	<i>Casuarina cunninghamiana</i>	62	80	21	7	85	2a	7.50	3.01	Retain				crowded, small deadwood
T817	River Oak	<i>Casuarina cunninghamiana</i>	14	15	9	2	80	2c	2.00	1.49	Retain				suppressed above, small deadwood
T818	River Oak	<i>Casuarina cunninghamiana</i>	13	14	10	3	80	2c	2.00	1.45	Retain				crowded, lots small deadwood
T819	River Oak	<i>Casuarina cunninghamiana</i>	13	14	9	5	80	2c	2.00	1.45	Retain				leaning canopy, small deadwood
T820	River Oak	<i>Casuarina cunninghamiana</i>	16	20	10	5	85	2c	2.00	1.68	Retain				suppressed above, small deadwood, leaning canopy
T821	Spotted Gum	<i>Corymbia maculata</i>	43	58	21	10	85	2a	5.18	2.63	Retain				
T822	Spotted Gum	<i>Corymbia maculata</i>	77	92	24	15	90	2a	9.24	3.20	Remove	Health	V2		
T823	Spotted Gum	<i>Corymbia maculata</i>	40	50	21	14	70	4c	4.80	2.47	Remove	Health			exposed wood, kino
T824	Spotted Gum	<i>Corymbia maculata</i>	53	63	23	10	70	4a	6.36	2.73	Retain				bracket fungi, exposed wood, small deadwood
T825	Tallowwood	<i>Eucalyptus microcorys</i>	27	32	19	6	90	2a	3.24	2.05	Retain				
T826	Tallowwood	<i>Eucalyptus microcorys</i>	46	51	21	9	85	2a	5.52	2.49	Retain				small deadwood
T827	Forest Red Gum	<i>Eucalyptus tereticornis</i>	24	33	17	6	70	3c	2.88	2.08	Retain				leaning canopy, lots small deadwood, exposed wood
T828	Forest Red Gum	<i>Eucalyptus tereticornis</i>	68	88	20	12	75	3c	8.22	3.14	Retain				kino, small-medium deadwood, competition, broken branches
T829	Tallowwood	<i>Eucalyptus microcorys</i>	53	57	19	9	90	2a	6.36	2.61	Retain				
T830	Tallowwood	<i>Eucalyptus microcorys</i>	70	65	17	8	85	2a	8.40	2.76	Remove	Health			small deadwood
T831	Dead Stag	Dead Stag	38	55	5	4	0	4a	4.50	2.57	Retain				
T832	Forest Red Gum	<i>Eucalyptus tereticornis</i>	17	17	3	1	85	2a	2.04	1.57	Remove	Golf Cse			small deadwood
T833	Rough-barked Apple	<i>Angophora floribunda</i>	36	26	10	3	80	2c	4.30	1.88	Remove	Golf Cse			epicormic growth, lots small deadwood
T834	Rough-barked Apple	<i>Angophora floribunda</i>	32	38	11	5	80	3c	3.84	2.20	Retain				lots small deadwood, kino,
T835	Forest Red Gum	<i>Eucalyptus tereticornis</i>	20	24	7	2	85	2a	2.40	1.82	Remove	Health			small deadwood
T836	Dead Stag	Dead Stag	16	20	3	0	0	4a	2.00	1.68	Remove	Dev			

No 13 Park Road, Wallacia

Tag No.	Common Name	Scientific Name	DBH	BD (cm)	Height (m)	Spread (m)	Vigour (%)	SULE	TPZ Radius (m)	SRZ Radius (m)	Ret/Rem	Reason	Visual Sig	Habitat Tree	Comments
T837	Willow Bottlebrush	<i>Callistemon salignus</i>	21	20	3	2	85	2a	2.50	1.68	Remove	Dev			small deadwood
T838	Rough-barked Apple	<i>Angophora floribunda</i>	37	42	10	5	75	2c	4.44	2.30	Remove	Health			suppressed above, lots small deadwood epicormic growth
T839	Forest Red Gum	<i>Eucalyptus tereticornis</i>	75	70	16	8	70	4c	9.00	2.85	Remove	Dev			borers, exposed wood, lots small-medium deadwood
T840	Weeping Bottlebrush	<i>Callistemon viminalis</i>	23	18	11	5	75	3c	2.74	1.61	Remove	Dev			suppressed above, small deadwood, low foliage
T841	Prickly-leaved Tea Tree	<i>Melaleuca stypheloides</i>	13	16	4	2	80	2c	2.00	1.53	Remove	Dev			suppressed above, competition, small deadwood
T842	Weeping Bottlebrush	<i>Callistemon viminalis</i>	20	22	11	7	85	2a	2.37	1.75	Remove	Health			small deadwood
T843	River Oak	<i>Casuarina cunninghamiana</i>	66	80	18	10	80	4c	7.92	3.01	Remove	Health			medium broken branch, multiple loppings, borers, small deadwood
T844	Radiata Pine	<i>Pinus radiata</i>	110	130	19	11	75	4c	13.20	3.69	Retain				multiple loppings ,kino, borers in loppings, small-medium deadwood
T845	Brush Box	<i>Lophostemon confertus</i>	34	45	10	4	90	2a	4.13	2.37	Retain				small deadwood
T846	Brush Box	<i>Lophostemon confertus</i>	58	93	16	8	90	2a	6.92	3.21	Retain				
T847	Brush Box	<i>Lophostemon confertus</i>	33	50	9	4	85	2a	3.96	2.47	Remove	Health			small deadwood
T848	Radiata Pine	<i>Pinus radiata</i>	90	110	24	10	45	4a	10.80	3.44	Remove	Health			dying canopy-stag, lots small-medium deadwood, epicormic growth
T849	Radiata Pine	<i>Pinus radiata</i>	35	40	10	1	0	4a	4.20	2.25	Remove	Dev			no foliage, exposed wood, borers
T850	Radiata Pine	<i>Pinus radiata</i>	26	50	5	2	60	3a	3.12	2.47	Retain				heavily leaning canopy, small deadwood,
T851	Radiata Pine	<i>Pinus radiata</i>	63	73	23	10	80	2a	7.56	2.90	Retain				
T852	Radiata Pine	<i>Pinus radiata</i>	43	56	22	8	80	2a	5.16	2.59	Remove	Health			
T853	Radiata Pine	<i>Pinus radiata</i>	56	70	23	10	60	4c	6.72	2.85	Retain				possible lightning strike, bark line removed top to bottom, borers in trunk, lots of kino
T854	Spotted Gum	<i>Corymbia maculata</i>	55	75	21	13	80	2a	6.60	2.93	Retain				
T855	Grey Gum	<i>Eucalyptus punctata</i>	32	37	17	9	90	2a	3.84	2.18	Retain				some bark damage & kino
T856	Forest Red Gum	<i>Eucalyptus tereticornis</i>	16	19	8	4	90	2a	2.00	1.65	Remove	Health			
T857	Grey Gum	<i>Eucalyptus punctata</i>	29	34	15	8	50	4a	3.48	2.10	Retain				extensive damage to bark for 90% of circumference, exposed wood, borers, kino
T858	Cabbage Gum	<i>Eucalyptus amplifolia</i>	31	35	16	9	80	2a	3.72	2.13	Remove	Health			bark damage at base
T859	Grey Gum	<i>Eucalyptus punctata</i>	28	34	16	8	60	4c	3.36	2.10	Remove	Health			extensive bark damage, exposed wood, borers in trunk
T860	Forest Red Gum	<i>Eucalyptus tereticornis</i>	64	74	19	12	45	4c	7.68	2.92	Retain				extensive bark damage 0-4m full circumference, exposed wood, lots kino, leaning 15 degrees, borers in trunk
T861	Radiata Pine	<i>Pinus radiata</i>	62	70	24	13	80	2a	7.44	2.85	Remove	Earthwks	V3		minor bark damage, kino
T862	River Oak	<i>Casuarina cunninghamiana</i>	51	71	23	8	90	2a	6.12	2.87	Retain				
T863	Broad-leaved Ironbark	<i>Eucalyptus fibrosa</i>	48	58	15	13	80	2a	5.76	2.63	Remove	Health			
T864	Radiata Pine	<i>Pinus radiata</i>	54	74	16	9	20	4a	6.48	2.92	Retain				dying, 20% canopy left, bark damage 0-4m, kino, large deadwood
T865	River Oak	<i>Casuarina cunninghamiana</i>	62	82	22	11	70	2a	7.44	3.04	Retain				crowded, canopy off centre, leaning slightly
T866	River Oak	<i>Casuarina cunninghamiana</i>	57	80	24	16	70	2a	6.84	3.01	Retain				2x trunks at 0m, stress splits in bark 0-1.5m, leaning >15 degrees
T867	River Oak	<i>Casuarina cunninghamiana</i>	55	75	23	9	75	2a	6.60	2.93	Retain				crowded, canopy off centre
T868	River Oak	<i>Casuarina cunninghamiana</i>	26	42	20	8	90	2a	3.12	2.30	Retain				
T869	River Oak	<i>Casuarina cunninghamiana</i>	20	30	14	6	80	2a	2.40	2.00	Retain				crowded, slightly suppressed
T870	River Oak	<i>Casuarina cunninghamiana</i>	58	70	24	10	75	2a	6.97	2.85	Retain				2x trunks at 1.5m, med deadwood
T871	River Oak	<i>Casuarina cunninghamiana</i>	14	18	6	3	90	2a	2.00	1.61	Retain				
T872	River Oak	<i>Casuarina cunninghamiana</i>	11	17	12	4	90	2a	2.00	1.57	Retain				
T873	River Oak	<i>Casuarina cunninghamiana</i>	10	14	8	3	90	2a	2.00	1.45	Retain				
T874	River Oak	<i>Casuarina cunninghamiana</i>	11	15	4	5	60	3c	2.00	1.49	Remove	Earthwks			crowded, suppressed, leaning
T875	Tallowwood	<i>Eucalyptus microcorys</i>	24	37	12	11	90	2a	2.88	2.18	Remove	Earthwks			
T876	Forest Red Gum	<i>Eucalyptus tereticornis</i>	61	71	23	13	90	2a	7.32	2.87	Remove	Earthwks	V3		
T877	Forest Red Gum	<i>Eucalyptus tereticornis</i>	38	44	12	7	80	2a	4.56	2.34	Remove	Dev			crowded, canopy off centre
T878	Tallowwood	<i>Eucalyptus microcorys</i>	39	46	16	11	90	2a	4.68	2.39	Remove	Dev			

No 13 Park Road, Wallacia

Tag No.	Common Name	Scientific Name	DBH	BD (cm)	Height (m)	Spread (m)	Vigour (%)	SULE	TPZ Radius (m)	SRZ Radius (m)	Ret/Rem	Reason	Visual Sig	Habitat Tree	Comments
T879	Tallowwood	<i>Eucalyptus microcorys</i>	30	38	17	12	90	2a	3.60	2.20	Remove	Dev			
T880	norfolk is pine		46	56	18	7	90	2a	5.52	2.59	Retain				
T881	Grey Box	<i>Eucalyptus moluccana</i>	24	30	14	6	90	2a	2.88	2.00	Retain				
T882	Tallowwood	<i>Eucalyptus microcorys</i>	41	53	22	11	90	2a	4.92	2.53	Retain				
T883	Forest Red Gum	<i>Eucalyptus tereticornis</i>	190	250	27	20	80	2a	22.80	4.86	Retain		V1		
T884	Tallowwood	<i>Eucalyptus microcorys</i>	34	44	19	10	90	2a	4.08	2.34	Retain				
T885	Tallowwood	<i>Eucalyptus microcorys</i>	51	60	24	10	90	2a	6.12	2.67	Remove	Earthwks			
T886	Forest Red Gum	<i>Eucalyptus tereticornis</i>	26	30	9	5	70	2d	3.12	2.00	Retain				poor form, lots small deadwood, sparse canopy
T887	Tallowwood	<i>Eucalyptus microcorys</i>	50	55	22	10	90	2a	6.05	2.57	Retain				
T888	Eucalyptus sp. (planted)	<i>Eucalyptus sp.</i>	18	23	7	6	70	3d	2.16	1.79	Remove	Golf Cse			broken branch at 1m, exposed wood, canopy dieback - 25% left, lots small deadwood
T889	Tallowwood	<i>Eucalyptus microcorys</i>	41	51	16	8	90	2a	4.92	2.49	Retain				crowded
T890	White Mahogany	<i>Eucalyptus acmenoides</i>	47	54	20	11	90	2a	5.64	2.55	Remove	Dev			
T891	Forest Red Gum	<i>Eucalyptus tereticornis</i>	23	29	6	4	90	2a	2.76	1.97	Remove	Dev			
T892	Broad-leaved Hakea	<i>Hakea dactyloides</i>	16	26	3	3	80	3a	2.00	1.88	Remove	Dev			
T893	Spotted Gum	<i>Corymbia maculata</i>	36	46	17	7	90	2a	4.32	2.39	Retain				
T894	Rough-barked Apple	<i>Angophora floribunda</i>	32	35	15	8	80	2a	3.89	2.13	Remove	Dev			
T895	Spotted Gum	<i>Corymbia maculata</i>	20	27	17	6	90	2a	2.40	1.91	Remove	Dev			
T896	Forest Red Gum	<i>Eucalyptus tereticornis</i>	17	20	8	4	80	2a	2.04	1.68	Remove	Health			
T897	Forest Red Gum	<i>Eucalyptus tereticornis</i>	30	36	16	5	45	4c	3.60	2.15	Remove	Dev			extensive bark damage 0-1.5m, exposed wood, kino, borers in trunk, broken 2nd trunk at 2m
T898	Grey Box	<i>Eucalyptus moluccana</i>	16	27	7	4	60	3c	2.00	1.91	Remove	Dev			3x trunks at 0m, crowded, poor form
T899	Grey Box	<i>Eucalyptus moluccana</i>	12	15	5	3	70	3c	2.00	1.49	Remove	Dev			crowded, suppressed, poor form
T900	Spotted Gum	<i>Corymbia maculata</i>	27	27	16	6	55	3b	3.24	1.91	Retain				2x trunks at 1.8m - in the process of failing - lots kino & splits
T901	Radiata Pine	<i>Pinus radiata</i>	90	85	21	11	80	2c	10.80	3.09	Retain				small-medium deadwood, kino-loppings
T902	Grey Gum	<i>Eucalyptus punctata</i>	18	19	6	2	85	2a	2.16	1.65	Retain				
T903	Grey Gum	<i>Eucalyptus punctata</i>	17	21	5	2	85	2a	2.00	1.72	Retain				small deadwood
T904	Grey Gum	<i>Eucalyptus punctata</i>	22	28	8	3	85	2a	2.64	1.94	Remove	Health			kino
T905	Forest Red Gum	<i>Eucalyptus tereticornis</i>	73	75	20	6	10	4a	8.76	2.93	Retain				epicormic growth, dying canopy
T906	Radiata Pine	<i>Pinus radiata</i>	57	59	10	6	85	2a	6.84	2.65	Remove	Health			multiple loppings-kino
T907	Radiata Pine	<i>Pinus radiata</i>	73	73	17	9	70	3b	8.76	2.90	Remove	Health			exposed wood, kino, multiple loppings, large dead branch
T908	Dead Stag	Dead Stag	94	107	15	11	0	4a	11.28	3.40	Remove	Health			
T909	Grey Gum	<i>Eucalyptus punctata</i>	60	55	14	7	80	3b	7.20	2.57	Remove	Golf Cse			small exposed wood, borers, kino, small deadwood
T910	Broad-leaved Ironbark	<i>Eucalyptus fibrosa</i>	37	43	14	8	85	2a	4.44	2.32	Remove	Health			kino
T911	Spotted Gum	<i>Corymbia maculata</i>	25	42	15	5	75	4c	2.95	2.30	Retain				exposed wood, lots small deadwood, kino, leaning canopy
T912	Broad-leaved Ironbark	<i>Eucalyptus fibrosa</i>	44	54	18	9	90	2a	5.28	2.55	Retain				
T913	Forest Red Gum	<i>Eucalyptus tereticornis</i>	21	26	8	2	85	2a	2.52	1.88	Retain				small deadwood
T914	Rough-barked Apple	<i>Angophora floribunda</i>	23	20	6	2	80	3a	2.76	1.68	Retain				small deadwood, kino, exposed wood @ base
T915	Broad-leaved Ironbark	<i>Eucalyptus fibrosa</i>	33	38	17	6	85	2a	3.96	2.20	Retain				small deadwood
T916	Grey Gum	<i>Eucalyptus moluccana</i>	99	103	24	15	80	2c	11.88	3.35	Remove	Dev	V2	Cat-3	lots small deadwood, epicormic growth,
T917	Thin-leaved Stringybark	<i>Eucalyptus eugenioides</i>	86	96	22	11	75	3b	10.32	3.25	Retain			Cat-3	exposed wood, borers, small deadwood, suppressed above
T918	Forest Red Gum	<i>Eucalyptus tereticornis</i>	170	230	29	20	85	2c	20.40	4.70	Remove	Dev	V1		medium-large deadwood
T919	Grey Box	<i>Eucalyptus moluccana</i>	50	52	23	6	70	3c	6.00	2.51	Remove	Dev			narrow canopy, competition, epicormic growth, small deadwood
T920	Forest Red Gum	<i>Eucalyptus tereticornis</i>	39	43	20	7	75	3c	4.68	2.32	Retain				small exposed wood @ base, small deadwood, crowded canopy
T921	Forest Red Gum	<i>Eucalyptus tereticornis</i>	64	80	23	8	85	2a	7.68	3.01	Retain				small deadwood, crowded canopy

No 13 Park Road, Wallacia

Tag No.	Common Name	Scientific Name	DBH	BD (cm)	Height (m)	Spread (m)	Vigour (%)	SULE	TPZ Radius (m)	SRZ Radius (m)	Ret/Rem	Reason	Visual Sig	Habitat Tree	Comments
T922	Forest Red Gum	<i>Eucalyptus tereticornis</i>	115	140	24	10	75	3c	13.80	3.81	Retain				heavily leaning canopy, exposed wood on trunk halfway up, small deadwood, crowded canopy
T923	Forest Red Gum	<i>Eucalyptus tereticornis</i>	116	136	24	15	85	2a	13.92	3.77	Remove	Health	V2	Cat-3	small deadwood
T924	Forest Red Gum	<i>Eucalyptus tereticornis</i>	48	68	15	7	80	4c	5.76	2.81	Remove	Health			exposed wood, leaning canopy, suppressed above, small broken branches
T925	Thin-leaved Stringybark	<i>Eucalyptus eugenoides</i>	159	168	23	12	60	4c	19.08	4.12	Retain			Cat-3	1x dead trunk-hollow!, exposed wood, epicormic growth, borers, kino
T926	Forest Red Gum	<i>Eucalyptus tereticornis</i>	110	85	19	9	80	2c	13.20	3.09	Retain				lots small deadwood
T927	Forest Red Gum	<i>Eucalyptus tereticornis</i>	45	48	23	8	85	2a	5.40	2.43	Retain				small deadwood, crowded
T928	Forest Red Gum	<i>Eucalyptus tereticornis</i>	33	39	14	5	75	3b	3.96	2.23	Retain				exposed wood, kino, suppressed above, small deadwood
T929	Forest Red Gum	<i>Eucalyptus tereticornis</i>	100	120	24	11	85	2a	12.00	3.57	Remove	Health		Cat-3	small deadwood
T930	Thin-leaved Stringybark	<i>Eucalyptus eugenoides</i>	75	84	9	4	30	4a	9.00	3.08	Retain			Cat-2	hollow stag, epicormic growth, possible habitat tree
T931	Forest Red Gum	<i>Eucalyptus tereticornis</i>	24	27	11	3	85	2c	2.88	1.91	Retain				suppressed above, small deadwood
T932	Forest Red Gum	<i>Eucalyptus tereticornis</i>	95	120	24	17	80	3c	11.40	3.57	Retain		V2		exposed wood on main trunk, large broken branches, kino
T933	Patula Pine	<i>Pinus patula</i>	50	65	12	7	70	3c	6.00	2.76	Retain				leaning canopy, multiple loppings-kino, small-medium deadwood
T934	Forest Red Gum	<i>Eucalyptus tereticornis</i>	51	55	13	7	85	3c	6.12	2.57	Remove	Health			exposed wood, kino, lots small deadwood,
T935	Forest Red Gum	<i>Eucalyptus tereticornis</i>	96	100	21	8	0	4a	11.53	3.31	Remove	Health			dead canopy, borers, exposed wood
T936	Dead Stag	Dead Stag	26	30	15	4	0	4a	3.12	2.00	Remove	Health			
T937	Dead Stag	Dead Stag	44	90	19	7	0	4a	5.25	3.17	Remove	Health			
T938	Forest Red Gum	<i>Eucalyptus tereticornis</i>	234	270	25	16	75	4c	28.12	5.02	Retain		V2	Cat-2	exposed wood, borers, medium dead trunk spout, small-medium deadwood
T939	Forest Red Gum	<i>Eucalyptus tereticornis</i>	53	63	23	9	75	3c	6.36	2.73	Retain				exposed wood, small deadwood
T940	Forest Red Gum	<i>Eucalyptus tereticornis</i>	63	75	23	8	75	3c	7.55	2.93	Remove	Health			exposed wood, crowded canopy, small deadwood
T941	Forest Red Gum	<i>Eucalyptus tereticornis</i>	38	43	22	7	75	4c	4.56	2.32	Remove	Health			exposed wood, borers, competition-crowded, small deadwood
T942	Grey Gum	<i>Eucalyptus punctata</i>	25	32	11	3	75	4c	3.00	2.05	Retain				exposed wood, borers, small deadwood
T943	Narrow-leaved Apple	<i>Angophora bakeri</i>	45	60	15	6	85	2a	5.35	2.67	Remove	Golf Cse			small deadwood
T944	Rough-barked Apple	<i>Angophora floribunda</i>	35	30	14	4	90	2a	4.20	2.00	Remove	Golf Cse			
T945	Bangalay	<i>Eucalyptus botryoides</i>	46	60	15	6	80	2c	5.52	2.67	Retain				leaning canopy, small deadwood, suppressed above
T946	Forest Red Gum	<i>Eucalyptus tereticornis</i>	58	70	20	8	80	3c	6.92	2.85	Retain				small deadwood, leaning canopy, exposed wood
T947	Swamp Oak	<i>Casuarina glauca</i>	69	90	17	7	90	2a	8.33	3.17	Retain				
T948	Rough-barked Apple	<i>Angophora floribunda</i>	160	280	26	15	70	3c	19.20	5.10	Retain		V2	Cat-1	HT20, possible bat roost
T949	Grey Gum	<i>Eucalyptus punctata</i>	35	38	20	7	90	2a	4.20	2.20	Retain				small deadwood
T950	Radiata Pine	<i>Pinus radiata</i>	40	45	12	4	75	2c	4.80	2.37	Retain				lots small deadwood, kino
T951	Sydney Blue Gum	<i>Eucalyptus saligna</i>	36	42	17	11	90	2a	4.32	2.30	Retain				
T952	Radiata Pine	<i>Pinus radiata</i>	56	76	14	10	80	2a	6.72	2.95	Retain				
T953	Brush Box	<i>Lophostemon confertus</i>	38	65	11	8	90	2a	4.56	2.76	Retain				
T954	Radiata Pine	<i>Pinus radiata</i>	57	77	13	10	80	2a	6.84	2.97	Retain				
T955	Brush Box	<i>Lophostemon confertus</i>	58	78	12	10	90	2a	6.96	2.98	Remove	Dev			
T956	Radiata Pine	<i>Pinus radiata</i>	63	88	20	10	75	2a	7.56	3.14	Remove	Dev			small deadwood
T957	Radiata Pine	<i>Pinus radiata</i>	75	100	19	14	60	3a	9.00	3.31	Remove	Health			lots small & med deadwood, thin canopy, kino
T958	Grey Box	<i>Eucalyptus moluccana</i>	12	14	5	2	50	4c	2.00	1.45	Retain				bark damage & kino 0-1.5m, exposed wood
T959	Radiata Pine	<i>Pinus radiata</i>	86	160	23	15	75	2a	10.32	4.03	Retain		V2		
T960	Grey Gum	<i>Eucalyptus punctata</i>	16	26	4	3	50	3b	2.00	1.88	Retain				4x trunks at 0m, poor form
T961	Grey Box	<i>Eucalyptus moluccana</i>	11	14	5	3	80	2a	2.00	1.45	Retain				
T962	Radiata Pine	<i>Pinus radiata</i>	72	102	24	13	75	3a	8.64	3.34	Retain		V3		lots med & small deadwood
T963	Radiata Pine	<i>Pinus radiata</i>	63	83	14	13	70	2a	7.56	3.06	Retain				

No 13 Park Road, Wallacia

Tag No.	Common Name	Scientific Name	DBH	BD (cm)	Height (m)	Spread (m)	Vigour (%)	SULE	TPZ Radius (m)	SRZ Radius (m)	Ret/Rem	Reason	Visual Sig	Habitat Tree	Comments
T964	Radiata Pine	<i>Pinus radiata</i>	47	67	13	9	70	2a	5.64	2.80	Remove	Health			extensively lopped
T965	Radiata Pine	<i>Pinus radiata</i>	92	192	16	15	45	4c	11.04	4.35	Retain				12 x trunks at 2m, 5 trunks dead, poor form
T966	Spotted Gum	<i>Corymbia maculata</i>	30	40	20	9	90	2a	3.60	2.25	Retain				
T967	Rough-barked Apple	<i>Angophora floribunda</i>	19	23	8	5	90	2a	2.28	1.79	Retain				
T968	ScribblyGum	<i>Eucalyptus sclerophylla</i>	30	34	8	8	80	2a	3.63	2.10	Retain				
T969	Spotted Gum	<i>Corymbia maculata</i>	42	55	21	10	90	2a	5.04	2.57	Retain				
T970	Broad-leaved Ironbark	<i>Eucalyptus fibrosa</i>	40	46	20	11	90	2a	4.80	2.39	Retain				
T971	Broad-leaved Ironbark	<i>Eucalyptus fibrosa</i>	48	53	20	10	90	2a	5.76	2.53	Retain				
T972	Spotted Gum	<i>Corymbia maculata</i>	32	44	18	11	90	2a	3.84	2.34	Retain				
T973	Rough-barked Apple	<i>Angophora floribunda</i>	25	33	13	5	80	2a	3.00	2.08	Remove	Health			
T974	Dead Stag	Dead Stag	67	87	7	6	0	4a	8.04	3.12	Retain				
T975	Forest Red Gum	<i>Eucalyptus tereticornis</i>	193	230	25	22	80	2a	23.10	4.70	Retain		V1	Cat-3	some med deadwood - with hollows 2x 0-5
T976	Forest Red Gum	<i>Eucalyptus tereticornis</i>	44	55	20	11	90	2a	5.28	2.57	Retain				
T977	Forest Red Gum	<i>Eucalyptus tereticornis</i>	26	32	13	6	65	3c	3.12	2.05	Retain				crowded, suppressed, epicormic growth, med deadwood, canopy off centre
T978	White Mahogany	<i>Eucalyptus acmenoides</i>	21	21	4	3	60	3c	2.46	1.72	Retain				crowded, suppressed, poor form, epicormic growth, small & medium deadwood
T979	Forest Red Gum	<i>Eucalyptus tereticornis</i>	37	47	20	12	80	2a	4.44	2.41	Remove	Dev			leaning slightly
T980	Forest Red Gum	<i>Eucalyptus tereticornis</i>	35	50	17	12	75	2a	4.20	2.47	Retain				crowded, canopy off centre
T981	Forest Red Gum	<i>Eucalyptus tereticornis</i>	21	27	12	8	70	2a	2.52	1.91	Retain				crowded, canopy off centre, small deadwood
T982	Forest Red Gum	<i>Eucalyptus tereticornis</i>	66	86	20	14	90	2a	7.92	3.11	Retain				
T983	Forest Red Gum	<i>Eucalyptus tereticornis</i>	48	58	19	7	75	2a	5.76	2.63	Retain				crowded, canopy off centre, med deadwood
T984	Forest Red Gum	<i>Eucalyptus tereticornis</i>	20	24	7	5	50	2c	2.40	1.82	Retain				crowded, canopy off centre, poor form, small deadwood
T985	Forest Red Gum	<i>Eucalyptus tereticornis</i>	48	68	21	14	80	2a	5.76	2.81	Retain				
T986	Forest Red Gum	<i>Eucalyptus tereticornis</i>	44	58	22	10	90	2a	5.28	2.63	Retain				
T987	Sickle Leaved Acacia	<i>Acacia falcata</i>	12	14	4	4	75	3a	2.00	1.45	Retain				
T988	Hickory Wattle	<i>Acacia implexa</i>	17	20	8	3	90	3a	2.04	1.68	Retain				
T989	Hickory Wattle	<i>Acacia implexa</i>	40	60	9	9	30	3c	4.80	2.67	Retain				30% canopy left, very poor form
T990	Forest Red Gum	<i>Eucalyptus tereticornis</i>	70	100	23	18	80	2a	8.40	3.31	Retain		V2		
T991	Forest Red Gum	<i>Eucalyptus tereticornis</i>	60	75	20	13	80	2a	7.22	2.93	Remove	Health			
T992	Patula Pine	<i>Pinus patula</i>	37	49	14	10	25	4a	4.44	2.45	Retain				declining, stressed, crowded, 25% canopy left, lots deadwood
T993	Forest Red Gum	<i>Eucalyptus tereticornis</i>	50	57	20	13	80	2a	5.99	2.61	Retain				crowded
T994	Patula Pine	<i>Pinus patula</i>	52	72	13	9	80	2a	6.24	2.88	Retain				
T995	Forest Red Gum	<i>Eucalyptus tereticornis</i>	68	78	20	15	75	3c	8.16	2.98	Retain				bark damage 0-1.5m, kino, canopy off centre, crowded
T996	Forest Red Gum	<i>Eucalyptus tereticornis</i>	64	74	23	9	80	2a	7.68	2.92	Retain				slight lean at base
T997	Forest Red Gum	<i>Eucalyptus tereticornis</i>	75	87	24	15	80	3a	9.00	3.12	Remove	Health	V2		minor bark damage, kino, exposed wood at 3m
T998	Forest Red Gum	<i>Eucalyptus tereticornis</i>	16	25	7	3	30	4a	2.00	1.85	Remove	Health			crowded, suppressed, exposed wood at 2m, borers in trunk
T999	Forest Red Gum	<i>Eucalyptus tereticornis</i>	19	24	8	4	30	4c	2.28	1.82	Retain				crowded, suppressed, bark damage at 2m, exposed wood, termites in trunk
T1000	Forest Red Gum	<i>Eucalyptus tereticornis</i>	130	160	24	18	55	3c	15.60	4.03	Remove	Health	V2		exposed wood at many loppings, kino, 2x major branch failures
T1001	Forest Red Gum	<i>Eucalyptus tereticornis</i>	82	93	24	24	55	4c	9.84	3.21	Retain		V2		Over-mature, bark damage 0-5m, exposed wood
T1002	Forest Red Gum	<i>Eucalyptus tereticornis</i>	43	48	24	12	90	2a	5.16	2.43	Retain				
T1003	White Mahogany	<i>Eucalyptus acmenoides</i>	37	44	20	11	80	2a	4.44	2.34	Retain				crowded, canopy off centre
T1004	Forest Red Gum	<i>Eucalyptus tereticornis</i>	22	26	9	6	50	3c	2.64	1.88	Retain				crowded, suppressed, canopy off centre, 25% of canopy left, lots small deadwood

No 13 Park Road, Wallacia

Tag No.	Common Name	Scientific Name	DBH	BD (cm)	Height (m)	Spread (m)	Vigour (%)	SULE	TPZ Radius (m)	SRZ Radius (m)	Ret/Rem	Reason	Visual Sig	Habitat Tree	Comments
T1005	Prickly-leaved Tea Tree	<i>Melaleuca stypheloides</i>	20	25	11	6	90	2a	2.40	1.85	Remove	Golf Cse			
T1006	Bangalay	<i>Eucalyptus botryoides</i>	65	95	21	14	90	2a	7.80	3.24	Retain		V3		
T1007	Forest Red Gum	<i>Eucalyptus tereticornis</i>	78	98	18	16	65	2a	9.36	3.28	Remove	Earthwks			stressed, lots epicormic growth, exposed wood at 1.5m, bark damage 0-4m, kino, med deadwood
T1008	Forest Red Gum	<i>Eucalyptus tereticornis</i>	140	180	28	24	80	2a	16.80	4.24	Retain		V1	Cat-3	some small & med deadwood
T1009	Mulberry Tree	<i>Morus alba</i>	30	38	8	7	80	3a	3.57	2.20	Retain				
T1010	Forest Red Gum	<i>Eucalyptus tereticornis</i>	79	100	24	14	80	2a	9.51	3.31	Retain		V3		
T1011	Forest Red Gum	<i>Eucalyptus tereticornis</i>	55	65	20	10	80	2a	6.60	2.76	Remove	Dev			2x trunks at 2m
T1012	Rough-barked Apple	<i>Angophora floribunda</i>	72	85	23	15	80	2a	8.64	3.09	Retain		V2		
T1013	Forest Red Gum	<i>Eucalyptus tereticornis</i>	84	98	16	12	85	2a	10.08	3.28	Retain				lots of small and medium dead wood
T1014	Grey Box	<i>Eucalyptus moluccana</i>	27	43	8	8	65	2c	3.23	2.32	Retain				cut stump at base, exposed wood, poor form
T1015	Forest Red Gum	<i>Eucalyptus tereticornis</i>	63	68	18	12	75	2a	7.56	2.81	Remove	Health			lots of small dead wood
T1016	Narrow-leaved Apple	<i>Angophora bakeri</i>	15	27	5	4	35	4a	2.00	1.91	Retain				termites in trunk, only 30% canopy, lots of dead wood
T1017	Forest Red Gum	<i>Eucalyptus tereticornis</i>	120	160	25	17	75	2a	14.40	4.03	Retain		V1		lots of small dead wood, exposed wood at 1.5m, over mature
T1018	Grey Box	<i>Eucalyptus moluccana</i>	47	46	15	9	75	2d	5.64	2.39	Retain				lightning damage, exposed wood on underside of most branches
T1019	Willow Bottlebrush	<i>Callistemon salignus</i>	25	45	5	6	75	2a	3.00	2.37	Remove	Health			small dead wood
T1020	River Oak	<i>Casuarina cunninghamiana</i>	67	107	22	9	25	4a	8.04	3.41	Retain		V3		exposed wood to 2.5m, borers in trunk to 4m
T1021	River Oak	<i>Casuarina cunninghamiana</i>	63	93	22	9	80	2a	7.56	3.21	Retain		V3		
T1022	Tallowwood	<i>Eucalyptus microcorys</i>	17	34	5	6	80	2a	2.04	2.10	Remove	Drainage			
T1023	River Oak	<i>Casuarina cunninghamiana</i>	13	18	8	4	80	2a	2.00	1.61	Retain				
T1024	River Oak	<i>Casuarina cunninghamiana</i>	10	18	13	4	90	2a	2.00	1.61	Remove	Drainage			
T1025	River Oak	<i>Casuarina cunninghamiana</i>	14	25	8	4	85	2a	2.00	1.85	Remove	Drainage			
T1026	River Oak	<i>Casuarina cunninghamiana</i>	10	16	14	3	90	2a	2.00	1.53	Remove	Drainage			
T1027	River Oak	<i>Casuarina cunninghamiana</i>	11	23	8	4	85	2a	2.00	1.79	Remove	Drainage			
T1028	River Oak	<i>Casuarina cunninghamiana</i>	10	23	11	4	90	2a	2.00	1.79	Remove	Drainage			
T1029	River Oak	<i>Casuarina cunninghamiana</i>	11	23	9	3	85	2a	2.00	1.79	Remove	Drainage			
T1030	River Oak	<i>Casuarina cunninghamiana</i>	22	32	18	7	90	2a	2.64	2.05	Remove	Drainage			
T1031	River Oak	<i>Casuarina cunninghamiana</i>	20	38	11	5	85	2a	2.40	2.20	Retain				
T1032	River Oak	<i>Casuarina cunninghamiana</i>	10	16	13	4	85	2a	2.00	1.53	Remove	Health			
T1033	River Oak	<i>Casuarina cunninghamiana</i>	16	36	11	5	65	4c	2.00	2.16	Remove	Drainage			large borer hole at base
T1034	River Oak	<i>Casuarina cunninghamiana</i>	10	19	12	5	90	2a	2.00	1.65	Remove	Drainage			
T1035	River Oak	<i>Casuarina cunninghamiana</i>	14	24	10	5	80	2a	2.00	1.82	Remove	Drainage			
T1036	River Oak	<i>Casuarina cunninghamiana</i>	17	27	12	5	90	2a	2.04	1.91	Remove	Drainage			
T1037	River Oak	<i>Casuarina cunninghamiana</i>	19	34	11	5	80	2a	2.31	2.10	Remove	Drainage			
T1038	River Oak	<i>Casuarina cunninghamiana</i>	26	36	14	7	90	2a	3.12	2.16	Remove	Drainage			
T1039	River Oak	<i>Casuarina cunninghamiana</i>	15	29	10	5	80	2a	2.00	1.97	Remove	Drainage			
T1040	River Oak	<i>Casuarina cunninghamiana</i>	14	24	8	5	90	2a	2.00	1.82	Remove	Health			
T1041	River Oak	<i>Casuarina cunninghamiana</i>	14	31	10	5	40	4a	2.00	2.02	Remove	Health			borers in trunk
T1042	River Oak	<i>Casuarina cunninghamiana</i>	18	28	12	6	65	4a	2.16	1.94	Remove	Health			borers in lower trunk, lots chewed wood at base
T1043	River Oak	<i>Casuarina cunninghamiana</i>	17	27	11	5	65	4a	2.04	1.91	Retain				borers in trunk
T1044	River Oak	<i>Casuarina cunninghamiana</i>	12	22	8	4	80	2a	2.00	1.75	Remove	Drainage			
T1045	River Oak	<i>Casuarina cunninghamiana</i>	12	19	11	4	80	2a	2.00	1.65	Remove	Health			
T1046	River Oak	<i>Casuarina cunninghamiana</i>	21	35	16	7	65	4a	2.52	2.13	Remove	Drainage			borers in base
T1047	River Oak	<i>Casuarina cunninghamiana</i>	20	50	12	5	85	2a	2.40	2.47	Remove	Health			
T1048	River Oak	<i>Casuarina cunninghamiana</i>	25	32	15	7	70	4c	3.03	2.05	Remove	Drainage			large borers in base, lots borer chewings

No 13 Park Road, Wallacia

Tag No.	Common Name	Scientific Name	DBH	BD (cm)	Height (m)	Spread (m)	Vigour (%)	SULE	TPZ Radius (m)	SRZ Radius (m)	Ret/Rem	Reason	Visual Sig	Habitat Tree	Comments
T1049	River Oak	<i>Casuarina cunninghamiana</i>	19	43	9	6	75	2a	2.29	2.32	Retain				
T1050	River Oak	<i>Casuarina cunninghamiana</i>	18	24	11	5	80	2a	2.16	1.82	Remove	Drainage			
T1051	River Oak	<i>Casuarina cunninghamiana</i>	16	26	10	6	80	2a	2.00	1.88	Retain				
T1052	River Oak	<i>Casuarina cunninghamiana</i>	13	22	12	4	80	2a	2.00	1.75	Remove	Drainage			
T1053	River Oak	<i>Casuarina cunninghamiana</i>	14	31	8	5	80	2a	2.00	2.02	Retain				
T1054	River Oak	<i>Casuarina cunninghamiana</i>	15	28	11	4	90	2a	2.00	1.94	Remove	Drainage			
T1055	River Oak	<i>Casuarina cunninghamiana</i>	16	27	9	6	80	2a	2.00	1.91	Remove	Health			
T1056	Forest Red Gum	<i>Eucalyptus tereticornis</i>	63	75	23	14	35	4a	7.58	2.93	Retain		V2		2x trunks at 0.3m, bark separation, borers in trunk to 2m, lots kino
T1057	River Oak	<i>Casuarina cunninghamiana</i>	19	27	11	7	85	2a	2.28	1.91	Retain				
T1058	River Oak	<i>Casuarina cunninghamiana</i>	13	22	11	4	90	2a	2.00	1.75	Retain				
T1059	River Oak	<i>Casuarina cunninghamiana</i>	15	22	9	6	80	2a	2.00	1.75	Remove	Health			
T1060	River Oak	<i>Casuarina cunninghamiana</i>	26	38	11	9	40	4c	3.12	2.20	Retain				1x major branch fail, exposed wood at 1m, borers in trunk
T1061	River Oak	<i>Casuarina cunninghamiana</i>	13	20	6	5	80	2a	2.00	1.68	Retain				
T1062	River Oak	<i>Casuarina cunninghamiana</i>	23	39	16	9	80	2a	2.76	2.23	Retain				
T1063	River Oak	<i>Casuarina cunninghamiana</i>	11	18	7	4	80	2a	2.00	1.61	Retain				
T1064	River Oak	<i>Casuarina cunninghamiana</i>	20	30	10	5	90	2a	2.40	2.00	Retain				
T1065	River Oak	<i>Casuarina cunninghamiana</i>	12	18	8	5	80	2a	2.00	1.61	Remove	Wetland			
T1066	River Oak	<i>Casuarina cunninghamiana</i>	13	21	8	3	90	2a	2.00	1.72	Retain				
T1067	River Oak	<i>Casuarina cunninghamiana</i>	10	15	7	4	75	2a	2.00	1.49	Remove	Wetland			
T1068	cabbage gum	<i>Eucalyptus amplifolia?</i>	47	67	23	15	80	2a	5.64	2.80	Retain		V2		
T1069	River Oak	<i>Casuarina cunninghamiana</i>	12	19	7	4	75	2a	2.00	1.65	Retain				
T1070	River Oak	<i>Casuarina cunninghamiana</i>	13	26	8	5	90	2a	2.00	1.88	Retain				
T1071	River Oak	<i>Casuarina cunninghamiana</i>	31	44	9	9	75	3c	3.76	2.34	Remove	Wetland			poor form due to branch structure
T1072	Cabbage Gum	<i>Eucalyptus amplifolia</i>	24	34	9	7	50	3b	2.83	2.10	Retain				regrown from cut stump, exposed wood 0-1m, termites in trunk
T1073	River Oak	<i>Casuarina cunninghamiana</i>	11	14	7	4	75	2a	2.00	1.45	Retain				
T1074	Grey Box	<i>Eucalyptus moluccana</i>	19	30	12	5	80	3c	2.24	2.00	Retain				3x trunks at 0.2m, crowded
T1075	River Oak	<i>Casuarina cunninghamiana</i>	11	15	8	2	75	2a	2.00	1.49	Retain				
T1076	Grey Box	<i>Eucalyptus moluccana</i>	21	26	10	5	80	2a	2.55	1.88	Retain				
T1077	River Oak	<i>Casuarina cunninghamiana</i>	18	32	12	4	75	2a	2.16	2.05	Retain				
T1078	Forest Red Gum	<i>Eucalyptus tereticornis</i>	24	32	20	5	80	2a	2.88	2.05	Retain				
T1079	River Oak	<i>Casuarina cunninghamiana</i>	16	26	10	4	75	2a	2.00	1.88	Retain				Some small dead wood
T1080	Cabbage Gum	<i>Eucalyptus amplifolia</i>	42	45	18	11	80	2a	5.06	2.37	Retain				
T1081	River Oak	<i>Casuarina cunninghamiana</i>	12	15	8	4	70	2a	2.00	1.49	Retain				small dead wood
T1082	Hickory Wattle	<i>Acacia implexa</i>	14	21	4	3	90	3a	2.00	1.72	Retain				
T1083	River Oak	<i>Casuarina cunninghamiana</i>	18	30	10	6	75	2a	2.12	2.00	Retain				small dead wood
T1084	Hickory Wattle	<i>Acacia implexa</i>	20	25	9	7	80	3a	2.36	1.85	Retain				
T1085	River Oak	<i>Casuarina cunninghamiana</i>	11	18	9	4	75	2a	2.00	1.61	Retain				
T1086	Prickly Leaved Tea-tree	<i>Melaleuca stypheloides</i>	40	45	7	4	70	2a	4.86	2.37	Retain				
T1087	Forest Red Gum	<i>Eucalyptus tereticornis</i>	19	27	12	6	75	2a	2.28	1.91	Retain				Medium dead wood
T1088	Prickly Leaved Tea-tree	<i>Melaleuca stypheloides</i>	24	33	5	2	60	3c	2.88	2.08	Retain				severely pruned, most of canopy is gone
T1089	Prickly Leaved Tea-tree	<i>Melaleuca stypheloides</i>	13	17	6	5	75	2a	2.00	1.57	Retain				
T1090	Prickly Leaved Tea-tree	<i>Melaleuca stypheloides</i>	19	24	12	6	90	2a	2.28	1.82	Retain				
T1091	Cabbage Gum	<i>Eucalyptus amplifolia</i>	16	18	12	5	75	2a	2.00	1.61	Retain				
T1092	Prickly Leaved Tea-tree	<i>Melaleuca stypheloides</i>	12	18	7	5	90	2a	2.00	1.61	Retain				
T1093	Cabbage Gum	<i>Eucalyptus amplifolia</i>	16	20	11	4	75	2a	2.00	1.68	Retain				

No 13 Park Road, Wallacia

Tag No.	Common Name	Scientific Name	DBH	BD (cm)	Height (m)	Spread (m)	Vigour (%)	SULE	TPZ Radius (m)	SRZ Radius (m)	Ret/Rem	Reason	Visual Sig	Habitat Tree	Comments
T1094	Prickly Leaved Tea-tree	<i>Melaleuca stypheloides</i>	22	26	10	4	90	2a	2.64	1.88	Retain				
T1095	Cabbage Gum	<i>Eucalyptus amplifolia</i>	10	13	7	4	70	2a	2.00	1.41	Retain				
T1096	River Oak	<i>Casuarina cunninghamiana</i>	33	36	14	8	80	2a	4.01	2.16	Retain				
T1097	Cabbage Gum	<i>Eucalyptus amplifolia</i>	22	27	9	7	75	2a	2.64	1.91	Retain				
T1098	River Oak	<i>Casuarina cunninghamiana</i>	17	22	8	5	90	2a	2.04	1.75	Retain				
T1099	Forest Red Gum	<i>Eucalyptus tereticornis</i>	28	43	14	7	75	2a	3.36	2.32	Retain				
T1100	Cabbage Gum	<i>Eucalyptus amplifolia</i>	22	27	16	13	90	2a	2.64	1.91	Retain				
T1101	Forest Red Gum	<i>Eucalyptus tereticornis</i>	18	24	20	7	80	2a	2.16	1.82	Retain				
T1102	Prickly Leaved Tea-tree	<i>Melaleuca stypheloides</i>	18	24	7	4	90	2a	2.16	1.82	Retain				
T1103	Hickory Wattle	<i>Acacia implexa</i>	12	16	9	4	80	2a	2.00	1.53	Retain				small dead wood
T1104	River Oak	<i>Casuarina cunninghamiana</i>	17	23	7	7	80	2a	2.04	1.79	Retain				
T1105	Forest Red Gum	<i>Eucalyptus tereticornis</i>	36	64	19	8	80	2a	4.33	2.74	Retain				
T1106	River Oak	<i>Casuarina cunninghamiana</i>	69	75	18	15	80	2a	8.24	2.93	Retain		V3		
T1107	Hickory Wattle	<i>Acacia implexa</i>	10	12	4	5	40	3b	2.00	1.36	Retain				on a bad lean, almost horizontal
T1108	Prickly Leaved Tea-tree	<i>Melaleuca stypheloides</i>	26	29	8	4	85	2a	3.12	1.97	Retain				
T1109	Prickly Leaved Tea-tree	<i>Melaleuca stypheloides</i>	12	14	10	4	75	2a	2.00	1.45	Retain				
T1110	River Oak	<i>Casuarina cunninghamiana</i>	42	55	22	12	75	2a	4.98	2.58	Retain				
T1111	Prickly Leaved Tea-tree	<i>Melaleuca stypheloides</i>	19	45	9	6	75	2a	2.33	2.37	Retain				
T1112	Prickly Leaved Tea-tree	<i>Melaleuca stypheloides</i>	28	26	8	5	85	2a	3.31	1.88	Retain				
T1113	Forest Red Gum	<i>Eucalyptus tereticornis</i>	21	25	24	6	80	2a	2.52	1.85	Retain		V3		
T1114	Prickly Leaved Tea-tree	<i>Melaleuca stypheloides</i>	12	16	8	4	80	2a	2.00	1.53	Remove	Health			
T1115	Forest Red Gum	<i>Eucalyptus tereticornis</i>	22	27	22	6	45	4a	2.64	1.91	Retain				borers in trunk
T1116	Prickly Leaved Tea-tree	<i>Melaleuca stypheloides</i>	14	19	6	3	90	2a	2.00	1.65	Retain				
T1117	Prickly Leaved Tea-tree	<i>Melaleuca stypheloides</i>	10	14	8	2	80	2a	2.00	1.45	Retain				small dead wood
T1118	Prickly Leaved Tea-tree	<i>Melaleuca stypheloides</i>	16	20	12	4	80	2a	2.00	1.68	Retain				crowded
T1119	Prickly Leaved Tea-tree	<i>Melaleuca stypheloides</i>	12	16	9	3	80	2a	2.00	1.53	Retain				small dead wood
T1120	Forest Red Gum	<i>Eucalyptus tereticornis</i>	29	32	23	10	90	2a	3.48	2.05	Retain		V3		
T1121	Prickly Leaved Tea-tree	<i>Melaleuca stypheloides</i>	15	18	6	4	75	2d	2.00	1.61	Retain				exposed wood at 1.5m, small dead wood
T1122	Prickly Leaved Tea-tree	<i>Melaleuca stypheloides</i>	12	15	12	4	90	2a	2.00	1.49	Retain				
T1123	Prickly Leaved Tea-tree	<i>Melaleuca stypheloides</i>	11	14	7	2	80	2a	2.00	1.45	Retain				
T1124	Prickly Leaved Tea-tree	<i>Melaleuca stypheloides</i>	26	26	9	5	90	2a	3.08	1.88	Remove	Health			
T1125	Cabbage Gum	<i>Eucalyptus amplifolia</i>	21	30	16	5	60	4a	2.52	2.00	Retain				head fallen out, lots of dead wood, photo taken
T1126	Forest Red Gum	<i>Eucalyptus tereticornis</i>	28	33	22	9	80	2a	3.36	2.08	Retain				crowded
T1127	Cabbage Gum	<i>Eucalyptus amplifolia</i>	13	16	17	4	75	2a	2.00	1.53	Retain				small dead wood
T1128	Prickly Leaved Tea-tree	<i>Melaleuca stypheloides</i>	17	25	7	4	85	2a	2.05	1.85	Retain				
T1129	Grey Box	<i>Eucalyptus moluccana</i>	21	28	10	6	80	2a	2.52	1.94	Retain				small dead wood
T1130	Forest Red Gum	<i>Eucalyptus tereticornis</i>	27	33	23	9	80	2a	3.24	2.08	Retain		V3		
T1131	Thin-leaved Stringybark	<i>Eucalyptus eugenioides</i>	16	24	9	4	70	2a	2.00	1.82	Retain				
T1132	Prickly Leaved Tea-tree	<i>Melaleuca stypheloides</i>	25	32	7	4	90	2a	3.04	2.05	Retain				
T1133	Thin-leaved Stringybark	<i>Eucalyptus eugenioides</i>	38	48	20	10	0	2a	4.56	2.43	Retain				
T1134	Thin-leaved Stringybark	<i>Eucalyptus eugenioides</i>	36	39	23	12	80	2a	4.32	2.23	Retain				
T1135	Thin-leaved Stringybark	<i>Eucalyptus eugenioides</i>	13	17	7	2	80	2a	2.00	1.57	Retain				
T1136	Grey Box	<i>Eucalyptus moluccana</i>	37	40	23	13	85	2a	4.44	2.25	Retain		V3		
T1137	Thin-leaved Stringybark	<i>Eucalyptus eugenioides</i>	15	17	8	5	70	2b	2.00	1.57	Retain				significant lean
T1138	Thin-leaved Stringybark	<i>Eucalyptus eugenioides</i>	24	28	22	11	90	2a	2.88	1.94	Retain				

No 13 Park Road, Wallacia

Tag No.	Common Name	Scientific Name	DBH	BD (cm)	Height (m)	Spread (m)	Vigour (%)	SULE	TPZ Radius (m)	SRZ Radius (m)	Ret/Rem	Reason	Visual Sig	Habitat Tree	Comments
T1139	Thin-leaved Stringybark	<i>Eucalyptus eugenioides</i>	36	45	22	11	80	2a	4.32	2.37	Retain				small dead wood
T1140	Bangalay	<i>Eucalyptus botryoides</i>	40	36	12	10	85	2a	4.75	2.16	Remove	Health			
T1141	Dead Stag	Dead Stag	13	16	10	5	0	4a	2.00	1.53	Retain				dead
T1142	Grey Gum	<i>Eucalyptus punctata</i>	52	72	18	12	70	2a	6.24	2.88	Retain				damaged on north side by many golf ball strikes
T1143	Forest Red Gum	<i>Eucalyptus tereticornis</i>	12	14	5	4	75	2a	2.00	1.45	Retain				
T1144	Radiata Pine	<i>Pinus radiata</i>	87	125	23	9	80	2a	10.44	3.64	Retain		V2		
T1145	Thin-leaved Stringybark	<i>Eucalyptus eugenioides</i>	40	60	22	12	75	2a	4.80	2.67	Retain				small dead wood
T1146	Radiata Pine	<i>Pinus radiata</i>	65	92	15	12	80	2a	7.80	3.20	Retain				
T1147	Radiata Pine	<i>Pinus radiata</i>	54	75	22	6	70	2a	6.51	2.93	Remove	Drainage			small dead wood
T1148	Radiata Pine	<i>Pinus radiata</i>	87	125	21	13	80	2a	10.44	3.64	Retain		V2		
T1149	Forest Red Gum	<i>Eucalyptus tereticornis</i>	30	35	9	6	80	2a	3.60	2.13	Remove	Health			small dead wood
T1150	Bangalay	<i>Eucalyptus botryoides</i>	55	38	9	10	60	4c	6.56	2.20	Retain				borers in 3x trunks, exposed wood, poor form
T1151	Radiata Pine	<i>Pinus radiata</i>	57	67	15	11	80	2a	6.84	2.80	Remove	Earthwks			
T1152	Radiata Pine	<i>Pinus radiata</i>	50	65	20	12	80	2a	6.00	2.76	Remove	Drainage			
T1153	Forest Red Gum	<i>Eucalyptus tereticornis</i>	22	34	8	6	75	2a	2.64	2.10	Remove	Health			
T1154	Forest Red Gum	<i>Eucalyptus tereticornis</i>	36	39	22	7	70	4c	4.32	2.23	Retain				borers in trunk, crowded, leaning, canopy off centre
T1155	Bangalay	<i>Eucalyptus botryoides</i>	37	75	12	9	75	2a	4.44	2.93	Retain				
T1156	Narrow-leaved Ironbark	<i>Eucalyptus crebra</i>	38	44	23	12	90	2a	4.56	2.34	Remove	Drainage			
T1157	Forest Red Gum	<i>Eucalyptus tereticornis</i>	27	32	16	7	75	2a	3.24	2.05	Remove	Health			
T1158	Dead Stag	Dead Stag	24	28	18	4	0	4a	2.88	1.94	Remove	Health			
T1159	Radiata Pine	<i>Pinus radiata</i>	57	97	24	8	0	4a	6.84	3.27	Retain				dead
T1160	Narrow-leaved Ironbark	<i>Eucalyptus crebra</i>	22	27	20	6	80	2d	2.64	1.91	Retain				crowded
T1161	Bangalay	<i>Eucalyptus botryoides</i>	42	47	8	10	75	2a	5.02	2.41	Remove	Health			
T1162	Dead Stag	Dead Stag	50	60	7	2	0	4a	6.00	2.67	Remove	Earthwks			
T1163	Radiata Pine	<i>Pinus radiata</i>	87	76	12	11	0	2a	10.44	2.95	Remove	Health			lots of small dead wood
T1164	Cabbage Gum	<i>Eucalyptus amplifolia</i>	18	23	9	3	40	4c	2.16	1.79	Retain				borers in base, exposed wood at 0m and 1.5m
T1165	Forest Red Gum	<i>Eucalyptus tereticornis</i>	37	48	14	8	65	2b	4.44	2.43	Remove	Health			borers in trunk
T1166	Dead Stag	Dead Stag	80	120	20	12	0	4a	9.60	3.57	Retain				
T1167	Forest Red Gum	<i>Eucalyptus tereticornis</i>	29	34	22	7	80	2a	3.48	2.10	Retain				small dead wood
T1168	Forest Red Gum	<i>Eucalyptus tereticornis</i>	74	95	21	14	85	2a	8.88	3.24	Retain		V2		
T1169	Radiata Pine	<i>Pinus radiata</i>	40	57	24	7	80	2a	4.80	2.61	Retain				small dead wood
T1170	Grey Box	<i>Eucalyptus moluccana</i>	51	61	22	14	80	2a	6.12	2.69	Retain		V3		
T1171	Narrow-leaved Ironbark	<i>Eucalyptus crebra</i>	19	24	20	7	80	2a	2.28	1.82	Remove	Health			small dead wood
T1172	Forest Red Gum	<i>Eucalyptus tereticornis</i>	52	56	22	14	65	4c	6.24	2.59	Retain		V3		exposed wood 0-1.5m, termites in trunk, crowded
T1173	Forest Red Gum	<i>Eucalyptus tereticornis</i>	49	62	24	12	80	2a	5.88	2.71	Retain		V3		
T1174	Forest Red Gum	<i>Eucalyptus tereticornis</i>	75	85	23	13	80	2a	9.00	3.09	Remove	Earthwks	V2		
T1175	Forest Red Gum	<i>Eucalyptus tereticornis</i>	12	16	4	3	75	2a	2.00	1.53	Retain				
T1176	Jacaranda	<i>Jacaranda mimosifolia</i>	43	34	7	8	80	2a	5.14	2.10	Remove	Earthwks			
T1177	Thin-leaved Stringybark	<i>Eucalyptus eugenioides</i>	41	52	22	10	80	2a	4.92	2.52	Retain				
T1178	Grey Box	<i>Eucalyptus moluccana</i>	135	155	25	13	70	3d	16.20	3.98	Remove	Earthwks	V1		1x major trunk dead, hollows, Recently dropped major branches
T1179	Forest Red Gum	<i>Eucalyptus tereticornis</i>	102	122	26	16	80	2a	12.24	3.60	Remove	Earthwks	V1		exposed wood underside of branch 12m
T1180	River Oak	<i>Casuarina cunninghamiana</i>	49	50	23	12	85	2a	5.86	2.47	Remove	Earthwks			2x trunks at 0m
T1181	Forest Red Gum	<i>Eucalyptus tereticornis</i>	71	86	10	6	65	2d	8.52	3.11	Remove	Earthwks			dead wood, exposed wood at 6m, epicormic growth
T1182	River Oak	<i>Casuarina cunninghamiana</i>	25	36	16	7	80	2a	3.00	2.16	Retain				
T1183	Thin-leaved Stringybark	<i>Eucalyptus eugenioides</i>	71	87	25	10	80	2a	8.52	3.12	Remove	Earthwks	V2		

No 13 Park Road, Wallacia

Tag No.	Common Name	Scientific Name	DBH	BD (cm)	Height (m)	Spread (m)	Vigour (%)	SULE	TPZ Radius (m)	SRZ Radius (m)	Ret/Rem	Reason	Visual Sig	Habitat Tree	Comments
T1184	Bleeding Heart	<i>Homalanthus populifolius</i>	36	40	8	9	90	2a	4.32	2.25	Retain				
T1185	Forest Red Gum	<i>Eucalyptus tereticornis</i>	85	102	26	16	80	2a	10.20	3.34	Remove	Golf Cse	V1		
T1186	Rough-barked Apple	<i>Angophora floribunda</i>	35	55	23	9	75	2c	4.20	2.58	Retain				crowded, canopy off centre
T1187	Thin-leaved Stringybark	<i>Eucalyptus eugenoides</i>	54	64	9	9	65	2d	6.48	2.74	Retain				dead wood at top of tree
T1188	River Oak	<i>Casuarina cunninghamiana</i>	40	57	26	9	80	2a	4.80	2.61	Remove	Earthwks	V3		
T1189	Radiata Pine	<i>Pinus radiata</i>	52	82	22	11	80	2a	6.24	3.05	Remove	Golf Cse			
T1190	River Oak	<i>Casuarina cunninghamiana</i>	38	44	23	10	90	2a	4.56	2.34	Retain				
T1191	Radiata Pine	<i>Pinus radiata</i>	42	56	14	9	75	2b	5.04	2.59	Remove	Weed			lots of small/medium dead wood
T1192	Camphor Laurel	<i>Cinnamomum camphora</i>	93	115	22	16	90	2a	11.16	3.51	Retain		V1		exotic
T1193	Radiata Pine	<i>Pinus radiata</i>	55	67	18	12	80	2a	6.60	2.80	Remove	Health			
T1194	River Oak	<i>Casuarina cunninghamiana</i>	22	24	7	8	70	4a	2.64	1.82	Remove	Earthwks			lots of small/medium deadwood
T1194a	River Oak	<i>Cinnamomum camphora</i>	147	140	24	16	80	2a	17.64	3.81	Remove	Earthwks	V1		
T1195	River Oak	<i>Casuarina cunninghamiana</i>	37	54	26	11	80	2a	4.44	2.56	Remove	Golf Cse			
T1196	River Oak	<i>Casuarina cunninghamiana</i>	20	24	20	6	90	2a	2.40	1.82	Remove	Earthwks			
T1197	River Oak	<i>Casuarina cunninghamiana</i>	29	47	24	8	75	2a	3.48	2.41	Remove	Golf Cse	V3		lots of small/medium dead wood
T1198	River Oak	<i>Casuarina cunninghamiana</i>	24	32	12	5	75	2a	2.88	2.05	Remove	Earthwks			
T1199	River Oak	<i>Casuarina cunninghamiana</i>	16	28	7	5	75	2d	2.00	1.94	Remove	Golf Cse			lots of small/medium deadwood
T1200	River Oak	<i>Casuarina cunninghamiana</i>	36	32	18	8	90	2a	4.34	2.05	Remove	Health			
T1201	Forest Red Gum	<i>Eucalyptus tereticornis</i>	32	47	24	11	70	4a	3.84	2.41	Remove	Earthwks	V3		large splits in bark up to 3m
T1202	White Cedar	<i>Melia azedarach</i>	33	37	6	8	90	2a	3.91	2.18	Remove	Golf Cse			
T1203	River Oak	<i>Casuarina cunninghamiana</i>	58	78	23	7	75	2d	6.96	2.98	Retain		V3		large/small deadwood
T1204	a Cypress Pine	<i>Callitris sp.</i>	28	45	6	4	80	2a	3.40	2.37	Retain				
T1205	White Cedar	<i>Melia azedarach</i>	31	46	6	6	80	2a	3.72	2.39	Remove	Earthwks			
T1206	White Cedar	<i>Melia azedarach</i>	23	38	5	4	90	2a	2.76	2.20	Remove	Earthwks			
T1207	White Cedar	<i>Melia azedarach</i>	42	65	8	8	0	2a	5.02	2.76	Retain				
T1208	White Cedar	<i>Melia azedarach</i>	32	50	8	8	90	2a	3.82	2.47	Remove	Health			
T1209	Radiata Pine	<i>Pinus radiata</i>	62	67	18	15	0	4a	7.44	2.80	Remove	Earthwks	V3		dead
T1210	Cabbage Gum	<i>Cinnamomum camphora</i>	45	56	10	8	90	2a	5.44	2.59	Remove	Health			
T1211	Radiata Pine	<i>Pinus radiata</i>	47	67	20	9	0	4a	5.64	2.80	Remove	Dev			
T1212	Chinese Hackberry	<i>Celtis sinensis</i>	44	63	12	14	80	2a	5.29	2.73	Remove	Dev			
T1213	Silky Oak	<i>Grevillea robusta</i>	58	83	22	12	10	4a	6.96	3.06	Remove	Dev			very few leaves
T1214	Silky Oak	<i>Grevillea robusta</i>	35	57	22	10	80	2a	4.20	2.61	Remove	Dev			
T1215	Silky Oak	<i>Grevillea robusta</i>	34	47	20	9	80	2a	4.08	2.41	Remove	Dev			

Note 1: Visual Significance

V1 – High significance typically >25m height/ >20m spread / >600mm DBH – Large emergent tree
V2 – Moderate significance generally 15-25m height/ >10m spread>600mm DBH – Prominent tree typically with a large spread
V3 – Low significance >10m height/ >10m spread>600mm DBH –Typically a visually attractive low tree with large spread and DBH

Note 2: Habitat Trees

The habitat trees recorded within the study area fall under one of three categories:

Category 1: Significant habitat trees (high):

- Large hollow suitable for cockatoos or large forest owls >30cm and/or

No 13 Park Road, Wallacia

- Trees containing two (2) or more good quality medium hollows 10-30cm and/or
- >8 small hollows

Category 2: Significant habitat trees (moderate)

- Trees containing one medium hollow 10-30cm and/or
- 3-8 small hollows

Category 3: Remaining hollow bearing trees generally containing small or low numbers of hollows

Note 3: SULE Rating (refer to detailed breakdown in Schedule 3)

- 1A to 1C** Trees that appear to be retainable at the time of assessment with more than 40 years life expectancy with acceptable risk.
- 2A to 2D** Trees that appear to be retainable at the time of assessment with 15-40 years life expectancy with acceptable risk.
- 3A to 3D** Trees that appear to be retainable at the time of assessment with 5-15 years life expectancy with acceptable risk.
- 4A to 4F** Trees with a high level of risk and should be removed within 5 years.

Schedule 2

SULE Assessment and Retention / Removal Plans



- SULE**
- 1a >40 years life expectancy, sound tree
 - 1b >40 years life expectancy, with remedial care
 - 1c Tree of historical, commemorative merit or rarity
 - 2a 15 - 40 years life expectancy
 - 2b >40 years life expectancy, may represent future safety or nuisance problems
 - 2c >40 years life expectancy, suppressing better quality trees
 - 2d 15 - 40 years, with remedial care
 - 3a 5 - 15 years life expectancy
 - 3b >15 years life expectancy, may represent further safety or nuisance problems
 - 3c >15 years life expectancy, suppressing better quality trees
 - 3d 5 - 15 years life expectancy, requiring significant remedial work
 - 4a Dead or dying, suppressed or declining tree (Remove)
 - 4b A dangerous tree due to instability (Remove)
 - 4c A dangerous tree (Remove)
 - 4d A damaged tree, not safe to retain (Remove)
 - 4e Tree damaging or may cause damage to existing structures (Remove)
 - 4f Will become dangerous after removal of trees classed A-E (Remove)

Legend

Site boundary	Proposed buildings	Visually significant tree
Dams	Existing buildings	Exotic tree
Creek (source : LPI)	Habitat Tree	Dangerous tree
Roads - proposed	Trees to retain (750)	Tree Protection Zone (TPZ)
Asset protection zone	Trees to remove (485)	Structural Zone (SRZ)
		Bulk Earthworks

Aerial source: Nearmap

0 20 40 m

Disclaimer: The mapping is indicative of available space and location of features which may prove critical in assessing the viability of the proposed works. Mapping has been produced on a map base with an inherent level of inaccuracy, the location of all mapped features are to be confirmed by a registered surveyor.

PROJECT & MXD REFERENCE 13 Park Rd, Wallacia 18CMCT02_T001	DATE & ISSUE NUMBER 9/12/2019 Issue 1	SCALE & COORDINATE SYSTEM 1:1,000 @A3 GDA 1994 MGA Zone 56
TITLE Tree Assessment Plan - Zoom 1		
Document Path: N:\GIS STORAGE\N Drive\18CMCT02_ParkRd_Wallacia\MXD\18CMCT02_T001.mxd		

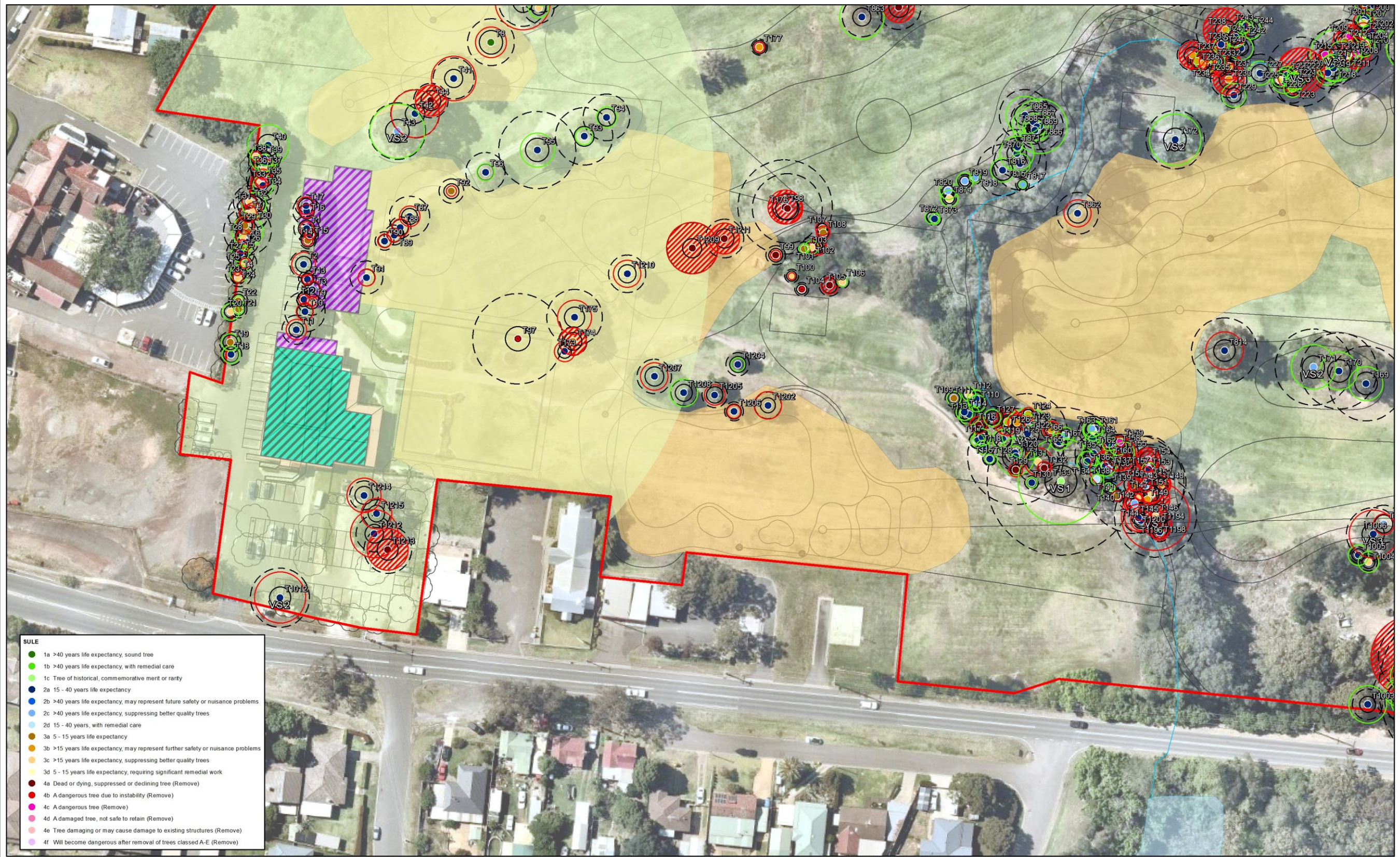

- SULE**
- 1a >40 years life expectancy, sound tree
 - 1b >40 years life expectancy, with remedial care
 - 1c Tree of historical, commemorative merit or rarity
 - 2a 15 - 40 years life expectancy
 - 2b >40 years life expectancy, may represent future safety or nuisance problems
 - 2c >40 years life expectancy, suppressing better quality trees
 - 2d 15 - 40 years, with remedial care
 - 3a 5 - 15 years life expectancy
 - 3b >15 years life expectancy, may represent further safety or nuisance problems
 - 3c >15 years life expectancy, suppressing better quality trees
 - 3d 5 - 15 years life expectancy, requiring significant remedial work
 - 4a Dead or dying, suppressed or declining tree (Remove)
 - 4b A dangerous tree due to instability (Remove)
 - 4c A dangerous tree (Remove)
 - 4d A damaged tree, not safe to retain (Remove)
 - 4e Tree damaging or may cause damage to existing structures (Remove)
 - 4f Will become dangerous after removal of trees classed A-E (Remove)

- Legend**
- | | | |
|-----------------------|-----------------------|----------------------------|
| Site boundary | Proposed buildings | Visually significant tree |
| Dams | Existing buildings | Exotic tree |
| Creek (source : LPI) | Habitat Tree | Dangerous tree |
| Roads - proposed | Trees to retain (750) | Tree Protection Zone (TPZ) |
| Asset protection zone | Trees to remove (465) | Structural Zone (SRZ) |
| | | Bulk Earthworks |

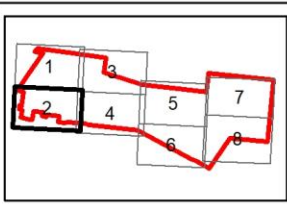

0 20 40 m

Disclaimer: The mapping is indicative of available space and location of features which may prove critical in assessing the viability of the proposed works. Mapping has been produced on a map base with an inherent level of inaccuracy, the location of all mapped features are to be confirmed by a registered surveyor.

PROJECT & MXD REFERENCE
 13 Park Rd, Wallacia
 18CMCT02_T001

DATE & ISSUE NUMBER
 9/12/2019
 Issue 1

SCALE & COORDINATE SYSTEM
 1:1,000 @A3
 GDA 1994 MGA Zone 56

TITLE
Tree Assessment Plan - Zoom 2

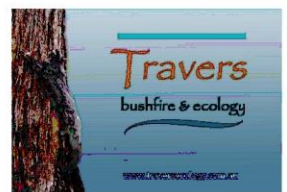

Document Path: N:\GIS STORAGE\N Drive\18CMCT02_ParkRd_Wallacia\MXD\18CMCT02_T001.mxd



- SULE**
- 1a >40 years life expectancy, sound tree
 - 1b >40 years life expectancy, with remedial care
 - 1c Tree of historical, commemorative merit or rarity
 - 2a 15 - 40 years life expectancy
 - 2b >40 years life expectancy, may represent future safety or nuisance problems
 - 2c >40 years life expectancy, suppressing better quality trees
 - 2d 15 - 40 years, with remedial care
 - 3a 5 - 15 years life expectancy
 - 3b >15 years life expectancy, may represent further safety or nuisance problems
 - 3c >15 years life expectancy, suppressing better quality trees
 - 3d 5 - 15 years life expectancy, requiring significant remedial work
 - 4a Dead or dying, suppressed or declining tree (Remove)
 - 4b A dangerous tree due to instability (Remove)
 - 4c A dangerous tree (Remove)
 - 4d A damaged tree, not safe to retain (Remove)
 - 4e Tree damaging or may cause damage to existing structures (Remove)
 - 4f Will become dangerous after removal of trees classed A-E (Remove)

- Legend**
- Site boundary
 - Dams
 - Creek (source : LPI)
 - Roads - proposed
 - Asset protection zone
 - Proposed buildings
 - Existing buildings
 - Habitat Tree
 - Trees to retain (750)
 - Trees to remove (465)
 - VS Visually significant tree
 - Exotic tree
 - Dangerous tree
 - Tree Protection Zone (TPZ)
 - Structural Zone (SRZ)
 - Bulk Earthworks

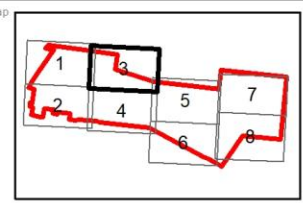

Aerial source: Noemap

0 20 40 m

Disclaimer: The mapping is indicative of available space and location of features which may prove critical in assessing the viability of the proposed works. Mapping has been produced on a map base with an inherent level of inaccuracy, the location of all mapped features are to be confirmed by a registered surveyor.

PROJECT & MXD REFERENCE
 13 Park Rd, Wallacia
 18CMCT02_T001

DATE & ISSUE NUMBER
 9/12/2019
 Issue 1

SCALE & COORDINATE SYSTEM
 1:1,000 @A3
 GDA 1994 MGA Zone 56

TITLE
 Tree Assessment Plan - Zoom 3



Document Path: N:\GIS STORAGE\N Drive\18CMCT02_ParkRd_Wallacia\MXD\18CMCT02_T001.mxd



SULE

- 1a >40 years life expectancy, sound tree
- 1b >40 years life expectancy, with remedial care
- 1c Tree of historical, commemorative merit or rarity
- 2a 15 - 40 years life expectancy
- 2b >40 years life expectancy, may represent future safety or nuisance problems
- 2c >40 years life expectancy, suppressing better quality trees
- 2d 15 - 40 years, with remedial care
- 3a 5 - 15 years life expectancy
- 3b >15 years life expectancy, may represent further safety or nuisance problems
- 3c >15 years life expectancy, suppressing better quality trees
- 3d 5 - 15 years life expectancy, requiring significant remedial work
- 4a Dead or dying, suppressed or declining tree (Remove)
- 4b A dangerous tree due to instability (Remove)
- 4c A dangerous tree (Remove)
- 4d A damaged tree, not safe to retain (Remove)
- 4e Tree damaging or may cause damage to existing structures (Remove)
- 4f Will become dangerous after removal of trees classed A-E (Remove)

Legend

Site boundary	Proposed buildings	Visually significant tree
Dams	Existing buildings	Exotic tree
Creek (source : LPI)	Habitat Tree	Dangerous tree
Roads - proposed	Trees to retain (750)	Tree Protection Zone (TPZ)
Asset protection zone	Trees to remove (465)	Structural Zone (SRZ)
		Bulk Earthworks

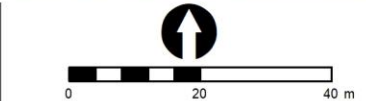

PROJECT & MXD REFERENCE
 13 Park Rd, Wallacia
 18CMCT02_T001

DATE & ISSUE NUMBER
 9/12/2019
 Issue 1

SCALE & COORDINATE SYSTEM
 1:1,000 @A3
 GDA 1994 MGA Zone 56

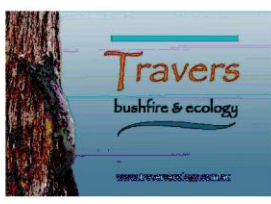

TITLE
Tree Assessment Plan - Zoom 4

Document Path: N:\GIS STORAGE\N Drive\18CMCT02_ParkRd_Wallacia\MXD\18CMCT02_T001.mxd

Disclaimer: The mapping is indicative of available space and location of features which may prove critical in assessing the viability of the proposed works. Mapping has been produced on a map base with an inherent level of inaccuracy, the location of all mapped features are to be confirmed by a registered surveyor.

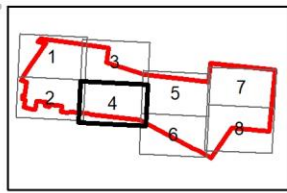

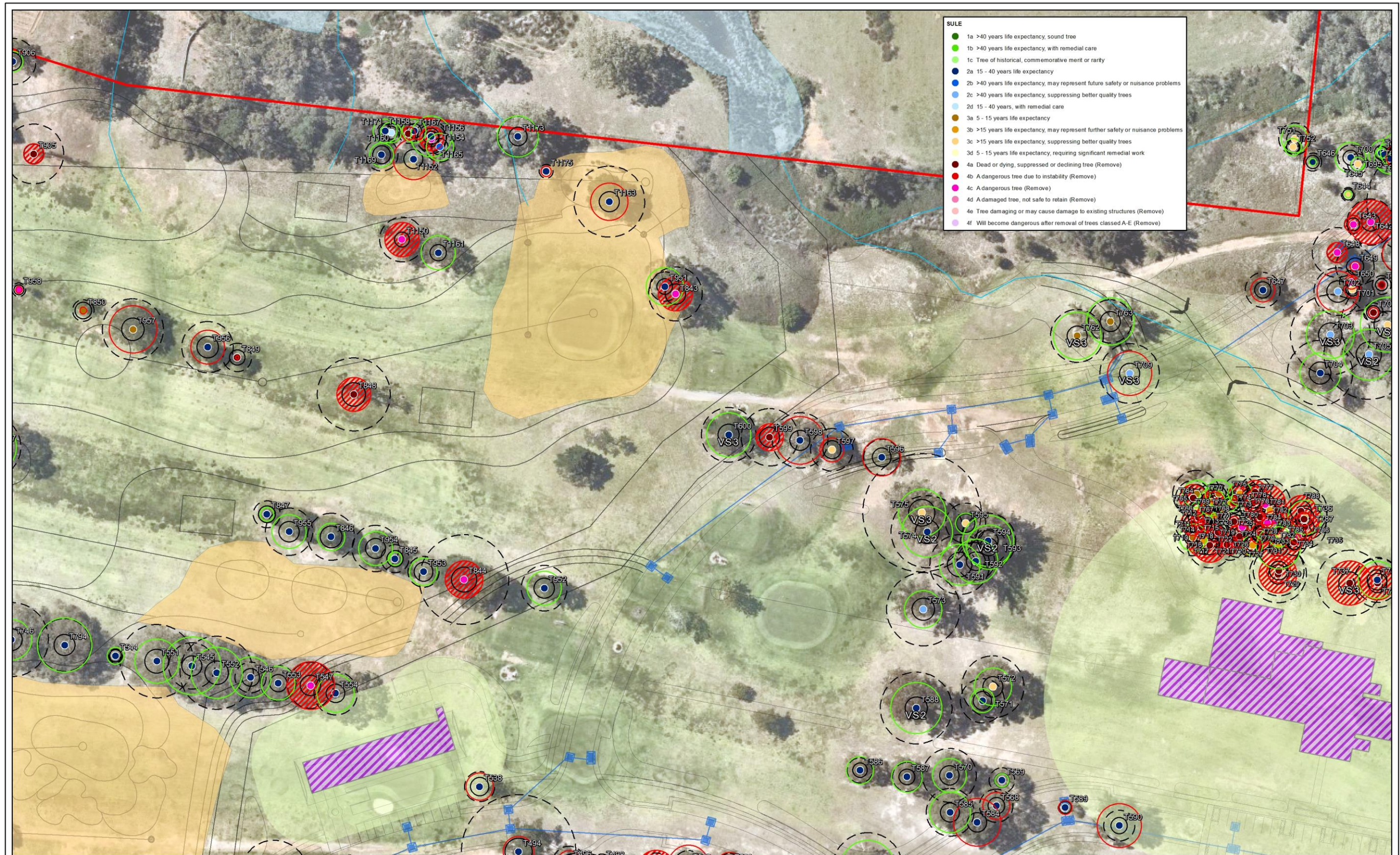

SULE

- 1a >40 years life expectancy, sound tree
- 1b >40 years life expectancy, with remedial care
- 1c Tree of historical, commemorative merit or rarity
- 2a 15 - 40 years life expectancy
- 2b >40 years life expectancy, may represent future safety or nuisance problems
- 2c >40 years life expectancy, suppressing better quality trees
- 2d 15 - 40 years, with remedial care
- 3a 5 - 15 years life expectancy
- 3b >15 years life expectancy, may represent further safety or nuisance problems
- 3c >15 years life expectancy, suppressing better quality trees
- 3d 5 - 15 years life expectancy, requiring significant remedial work
- 4a Dead or dying, suppressed or declining tree (Remove)
- 4b A dangerous tree due to instability (Remove)
- 4c A dangerous tree (Remove)
- 4d A damaged tree, not safe to retain (Remove)
- 4e Tree damaging or may cause damage to existing structures (Remove)
- 4f Will become dangerous after removal of trees classed A-E (Remove)

Legend

Site boundary	Proposed buildings	Visually significant tree
Dams	Existing buildings	Exotic tree
Creek (source : LPI)	Habitat Tree	Dangerous tree
Roads - proposed	Trees to retain (750)	Tree Protection Zone (TPZ)
Asset protection zone	Trees to remove (465)	Structural Zone (SRZ)
		Bulk Earthworks

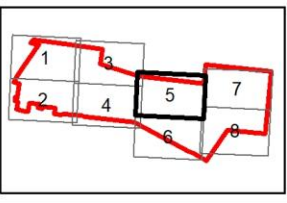

Aerial source: Neimap

0 20 40 m

Disclaimer: The mapping is indicative of available space and location of features which may prove critical in assessing the viability of the proposed works. Mapping has been produced on a map base with an inherent level of inaccuracy, the location of all mapped features are to be confirmed by a registered surveyor.

PROJECT & MXD REFERENCE
13 Park Rd, Wallacia
18CMCT02_T001

DATE & ISSUE NUMBER
9/12/2019
Issue 1

SCALE & COORDINATE SYSTEM
1:1,000 @A3
GDA 1994 MGA Zone 56

TITLE
Tree Assessment Plan - Zoom 5

Document Path: N:\GIS STORAGE\W Drive\18CMCT02_ParkRd_Wallacia\MXD\18CMCT02_T001.mxd

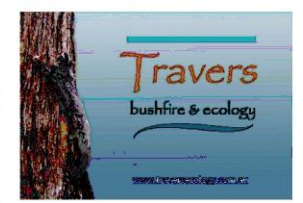



SULE

- 1a >40 years life expectancy, sound tree
- 1b >40 years life expectancy, with remedial care
- 1c Tree of historical, commemorative merit or rarity
- 2a 15 - 40 years life expectancy
- 2b >40 years life expectancy, may represent future safety or nuisance problems
- 2c >40 years life expectancy, suppressing better quality trees
- 2d 15 - 40 years, with remedial care
- 3a 5 - 15 years life expectancy
- 3b >15 years life expectancy, may represent further safety or nuisance problems
- 3c >15 years life expectancy, suppressing better quality trees
- 3d 5 - 15 years life expectancy, requiring significant remedial work
- 4a Dead or dying, suppressed or declining tree (Remove)
- 4b A dangerous tree due to instability (Remove)
- 4c A dangerous tree (Remove)
- 4d A damaged tree, not safe to retain (Remove)
- 4e Tree damaging or may cause damage to existing structures (Remove)
- 4f Will become dangerous after removal of trees classed A-E (Remove)

Legend

Site boundary	Proposed buildings	Visually significant tree
Dams	Existing buildings	Exotic tree
Creek (source : LPI)	Habitat Tree	Dangerous tree
Roads - proposed	Trees to retain (750)	Tree Protection Zone (TPZ)
Asset protection zone	Trees to remove (465)	Structural Zone (SRZ)
		Bulk Earthworks

Aerial source: Neamap

0 20 40 m

Disclaimer: The mapping is indicative of available space and location of features which may prove critical in assessing the viability of the proposed works. Mapping has been produced on a map base with an inherent level of inaccuracy, the location of all mapped features are to be confirmed by a registered surveyor.

PROJECT & MXD REFERENCE
 13 Park Rd, Wallacia
 18CMCT02_T001

DATE & ISSUE NUMBER
 9/12/2019
 Issue 1

SCALE & COORDINATE SYSTEM
 1:1,000 @A3
 GDA 1994 MGA Zone 56

TITLE
Tree Assessment Plan - Zoom 6



Document Path: N:\GIS STORAGE\N Drive\18CMCT02_ParkRd_Wallacia\MXD\18CMCT02_T001.mxd

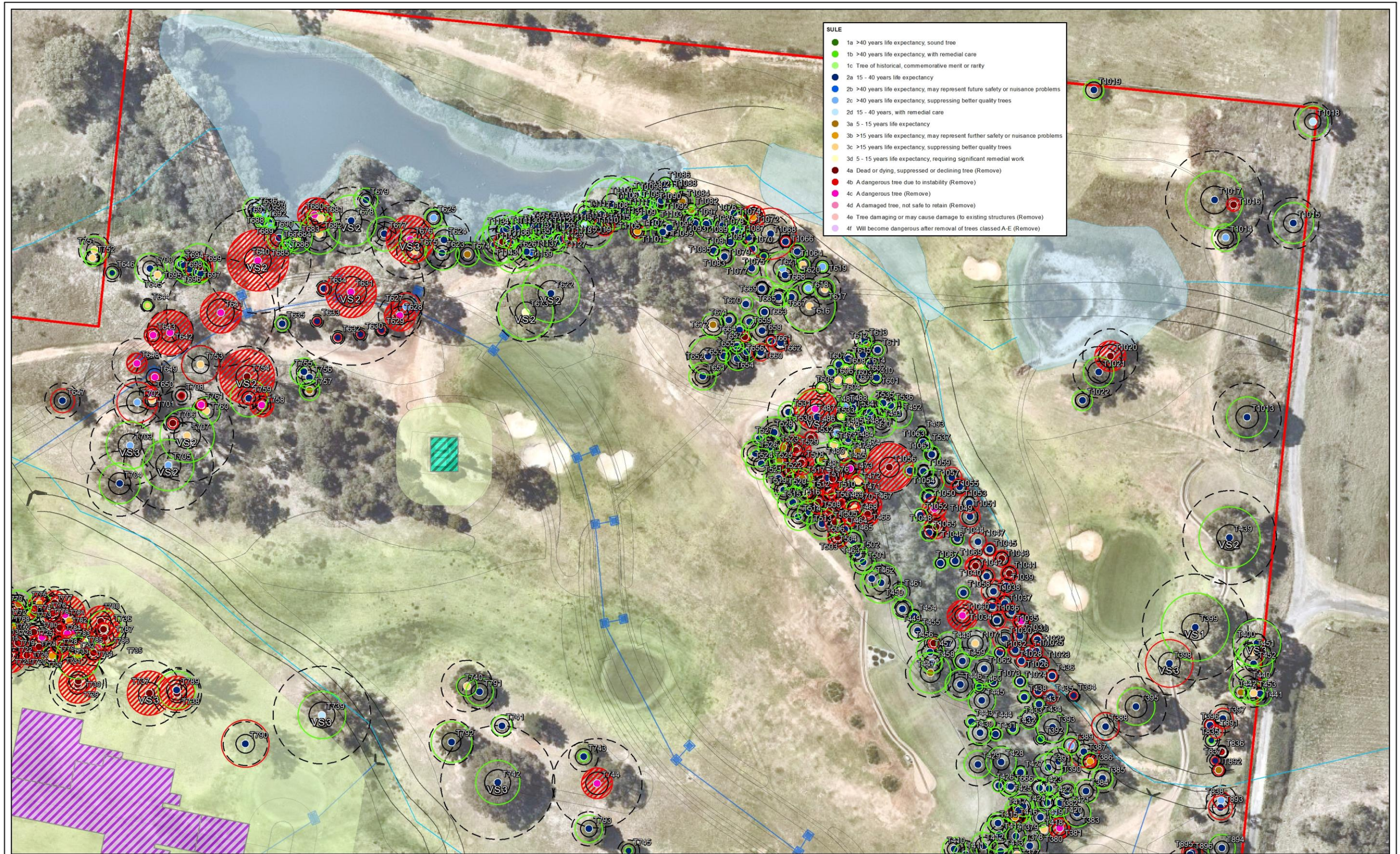

- SULE**
- 1a >40 years life expectancy, sound tree
 - 1b >40 years life expectancy, with remedial care
 - 1c Tree of historical, commemorative merit or rarity
 - 2a 15 - 40 years life expectancy
 - 2b >40 years life expectancy, may represent future safety or nuisance problems
 - 2c >40 years life expectancy, suppressing better quality trees
 - 2d 15 - 40 years, with remedial care
 - 3a 5 - 15 years life expectancy
 - 3b >15 years life expectancy, may represent further safety or nuisance problems
 - 3c >15 years life expectancy, suppressing better quality trees
 - 3d 5 - 15 years life expectancy, requiring significant remedial work
 - 4a Dead or dying, suppressed or declining tree (Remove)
 - 4b A dangerous tree due to instability (Remove)
 - 4c A dangerous tree (Remove)
 - 4d A damaged tree, not safe to retain (Remove)
 - 4e Tree damaging or may cause damage to existing structures (Remove)
 - 4f Will become dangerous after removal of trees classed A-E (Remove)

- Legend**
- ▭ Site boundary
 - ▭ Dams
 - ▭ Creek (source : LPI)
 - ▭ Roads - proposed
 - ▭ Asset protection zone
 - ▭ Proposed buildings
 - ▭ Existing buildings
 - ⊕ Habitat Tree
 - Trees to retain (750)
 - Trees to remove (465)
 - VS Visually significant tree
 - Exotic tree
 - Dangerous tree
 - Tree Protection Zone (TPZ)
 - Structural Zone (SRZ)
 - ▭ Bulk Earthworks

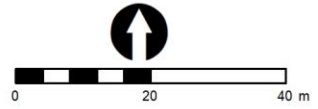
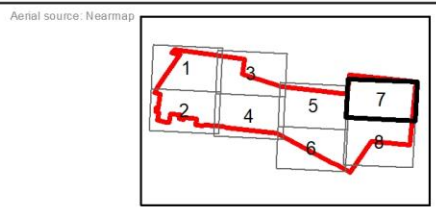

Disclaimer: The mapping is indicative of available space and location of features which may prove critical in assessing the viability of the proposed works. Mapping has been produced on a map base with an inherent level of inaccuracy, the location of all mapped features are to be confirmed by a registered surveyor.

PROJECT & MXD REFERENCE
 13 Park Rd, Wallacia
 18CMCT02_T001

DATE & ISSUE NUMBER
 9/12/2019
 Issue 1

SCALE & COORDINATE SYSTEM
 1:1,000 @A3
 GDA 1994 MGA Zone 56

TITLE
Tree Assessment Plan - Zoom 7

Document Path: N:\GIS STORAGE\N Drive\18CMCT02_ParkRd_Wallacia\MXDs\18CMCT02_T001.mxd



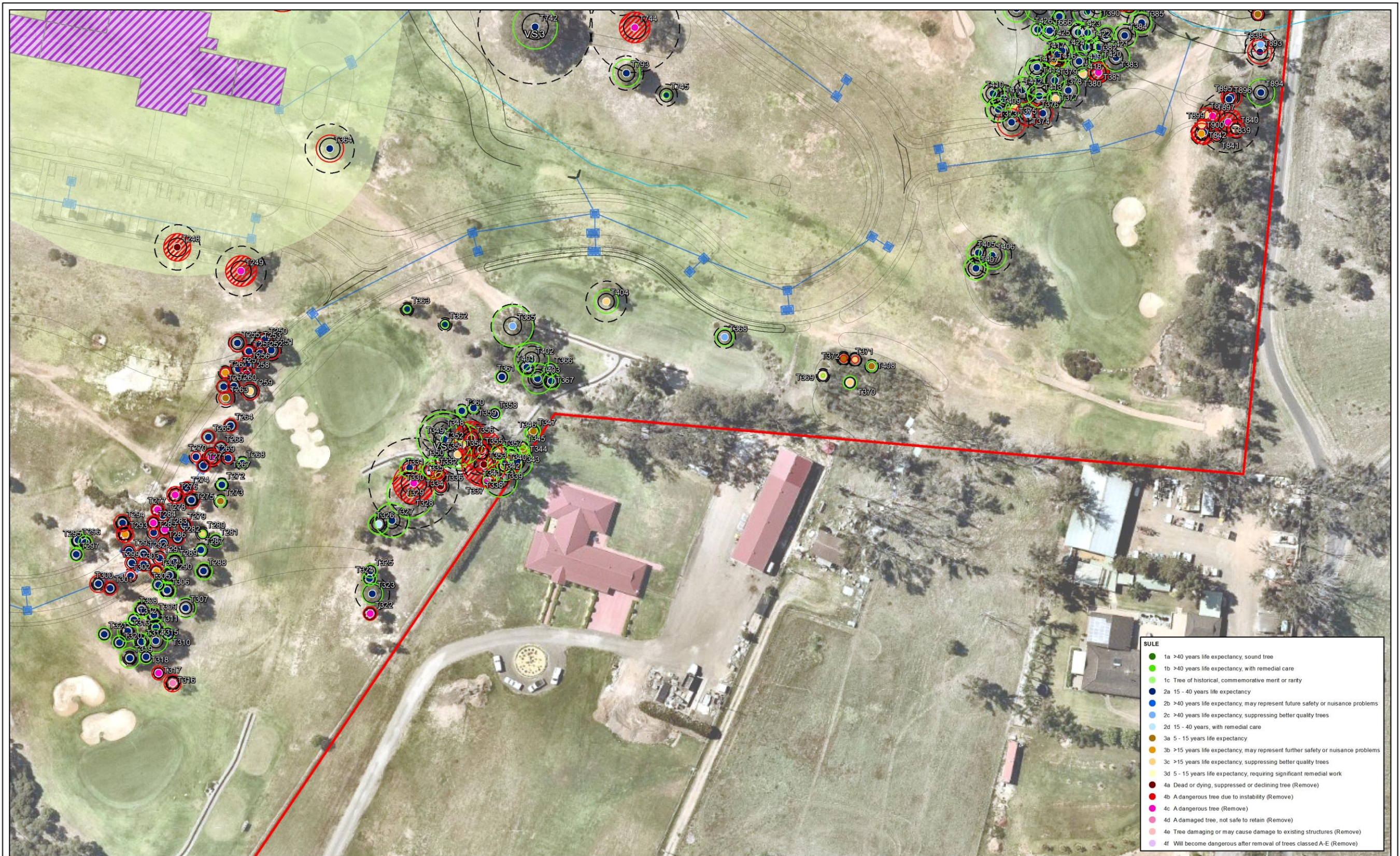

SULE	
● 1a	>40 years life expectancy, sound tree
● 1b	>40 years life expectancy, with remedial care
● 1c	Tree of historical, commemorative merit or rarity
● 2a	15 - 40 years life expectancy
● 2b	>40 years life expectancy, may represent future safety or nuisance problems
● 2c	>40 years life expectancy, suppressing better quality trees
● 2d	15 - 40 years, with remedial care
● 3a	5 - 15 years life expectancy
● 3b	>15 years life expectancy, may represent further safety or nuisance problems
● 3c	>15 years life expectancy, suppressing better quality trees
● 3d	5 - 15 years life expectancy, requiring significant remedial work
● 4a	Dead or dying, suppressed or declining tree (Remove)
● 4b	A dangerous tree due to instability (Remove)
● 4c	A dangerous tree (Remove)
● 4d	A damaged tree, not safe to retain (Remove)
● 4e	Tree damaging or may cause damage to existing structures (Remove)
● 4f	Will become dangerous after removal of trees classed A-E (Remove)

Legend		
Site boundary	Proposed buildings	Visually significant tree
Dams	Existing buildings	Exotic tree
Creek (source : LPI)	Habitat Tree	Dangerous tree
Roads - proposed	Trees to retain (750)	Tree Protection Zone (TPZ)
Asset protection zone	Trees to remove (465)	Structural Zone (SRZ)
		Bulk Earthworks

Aerial source: Neemap

0 20 40 m

Disclaimer: The mapping is indicative of available space and location of features which may prove critical in assessing the viability of the proposed works. Mapping has been produced on a map base with an inherent level of inaccuracy, the location of all mapped features are to be confirmed by a registered surveyor.

PROJECT & MXD REFERENCE
 13 Park Rd, Wallacia
 18CMCT02_T001

DATE & ISSUE NUMBER
 9/12/2019
 Issue 1

SCALE & COORDINATE SYSTEM
 1:1,000 @A3
 GDA 1994 MGA Zone 56

TITLE
Tree Assessment Plan - Zoom 8

Document Path: N:\GIS STORAGE\N Drive\18CMCT02_ParkRd_Wallacia\MXD\18CMCT02_T001.mxd

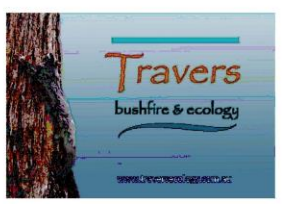

Schedule 3

SULE Ratings and Terminology

SULE Ratings and Terminology

SULE (an acronym for **safe useful life expectancy**). Particular consideration is given to the following points when making the final SULE assessment for each tree;

- obvious past influences (suppression)
- present health and condition, and future potential in current position
- estimated age at assessment in relation to the life expectancy for the species
- observed and potential structural defects which may influence potential life expectancy
- potential remedial work which may allow retention in the existing location.

An outline of the four relevant SULE categories and their subgroups used in this report is as follows:

1 Long SULE (trees that appear to be retainable at the time of assessment for more than 40 years with an acceptable level of risk)

- A** A structurally sound tree, located where potential future growth can be accommodated.
- B** A damaged or defective tree that could be made suitable in the long term (40+ years), where remedial care is given.
- C** A tree of particular significance (historical / commemorative merit or rarity) that warrants extensive efforts in securing long term retention.

2 Medium SULE (trees that appear to be retainable at the time of assessment, for 15 - 40 years with an acceptable level of risk)

- A** A tree predicted to only live between 15 and 40 years
- B** A tree that may live for more than 40 years, but should be removed to prevent safety or nuisance problems
- C** A tree that may live for more than 40 years, but should be removed to prevent competition with more suitable individuals, or to provide space for new planting
- D** A damaged or defective tree that could be made suitable in the medium term (15-40 years), where remedial care is given.

3 Short SULE (trees that appear to be retainable at the time of assessment for 5 - 15 years with an acceptable level of risk)

- A** A tree predicted to only live between 5 - 15 years
- B** A tree that may live for more than 15 years, but should be removed to prevent safety or nuisance problems
- C** A tree that may live for more than 15 years, but should be removed to prevent competition with more suitable individuals or to provide space for new planting
- D** A damaged or defective tree that could only be made suitable in the short term (5-15 years), and would require significant remedial work.

4 Removals (Trees with a high level of risk that should be removed within the next 5 years)

- A** A dead, dying, suppressed or declining tree

- B** A dangerous tree made so through instability or recent loss of neighbouring trees
- C** A dangerous tree made so through structural defects (cavities, decay, included bark, wounds or poor form)
- D** A damaged tree that is clearly not safe to retain
- E** A tree that is damaging, or may cause damage, to existing structures within 5 years
- F** A tree that will become dangerous after removal of neighbouring trees for the reasons given in A to E.

SULE ratings given to any tree in this report assumes that appropriate maintenance (if required) will be provided by a qualified arborist. Incorrect tree work practices can significantly accelerate tree suppression and increase hazard potential

EXPLANATION OF TERMINOLOGY USED

DBH - An acronym for bole or trunk diameter at breast height (1.4m from ground level).

Health - An indication of the vigour of a tree and is determined by the observed crown colour, density, presence of insect attack, the percentage of dead or dying branches and the amount of epicormic growth. The health of the canopy and that of the root system is interdependent and significant loss of tree vigour can result through both root and canopy (pruning, suppression) damage.

Suppressed, unhealthy trees have reduced ability to initiate internal defence systems (by the process of compartmentalisation) thus predisposing them to attack by insects and pathogenic decay organisms which increase the potential to drop dangerous branches.

Cambium - The part of the tree situated between the bark and the true wood of a tree. This area is where the tree transports water, nutrients and waste products to and from the roots and leaves. It is this area that is targeted when “ring-barking” a tree in order to disrupt the nutrient transport system of the tree and cause its death.

Condition - An evaluation of the structural integrity of a tree, including defects that may affect the useful life of an otherwise healthy individual. Such influencing factors include cavities and decay, weak unions between branches or trunks and faults of form or habit.

Fungal Attack - Many fungi have evolved to break down wood and return its nutrients to the biocycle of the environment. Fungi usually gain access to the wood through the actions of borers, or from physical damage resulting in exposed wood. Trees suffering from fungal attack may be severely weakened on a structural basis but may not show any external signs of the weakness. This can result in a catastrophic structural failure of a branch or trunk when subjected to stress such as a windy day.

Kino - A dark reddish exudate, rich in polyphenols (tannins), developed in the cambial region of eucalypts often as a result of injury; incorrectly called gum (Boland *et.al.* 1992).

Deadwood - The mature crown of a eucalypt maintains itself by the continual production of new crown units, which die in turn. Thus there will always be some dead branches in a healthy mature crown (Florence, 1996). Minor deadwood refers to dead branchlets, Major deadwood refers to main branches from the trunk.