

'ON-SITE WASTEWATER MANAGEMENT REPORT'

For:

Lot 1 West Wilchard Road, CASTLEREAGH, NSW

CLIENT: Keller

REFERENCE: REF-235615-A

DATE: 10 September 2015



Michael A. Chahine BE(Env Hons) MIEAust
Environmental Engineer – Team Leader
ENVIROTECH PTY. LTD.



Simon Doberer BS(Env)
Environmental Scientist – Team Leader
ENVIROTECH PTY. LTD.

COPYRIGHT © 2015

The information, including the intellectual property contained in this document is confidential and proprietary to ENVIROTECH PTY. LTD. It may be used only by the person, company or organisation to whom it is provided for the stated purpose for which it is provided. It must not be given to any other person, company or organisation without the prior written approval of the Director of ENVIROTECH PTY. LTD. ENVIROTECH PTY. LTD. reserves all legal rights and remedies in relation to any infringement of its rights in respect of confidential information.

Document Management				
Version	Date	Author	Reviewed	Author
A	11/09/2015	SD	11/09/2015	MC

TABLE OF CONTENTS

INTRODUCTION	4
Objective	4
Scope of Works	4
DESKTOP INFORMATION	5
SITE ASSESSMENT	6
Site Assessment Discussion	8
SOIL ASSESSMENT.....	9
Soil Assessment Discussion.....	11
ON-SITE WASTEWATER MANAGEMENT SYSTEM DESIGN	12
Site Modifications Recommended.....	13
RECOMMENDATIONS.....	14
LIMITATIONS.....	15

.....

- Appendix A: Site Plans
- Appendix F: Operation & Maintenance Guidelines
- Appendix G: Water Conservation
- Appendix H: Beds and Trench Descriptions

INTRODUCTION

EnviroTech Pty. Ltd. has been engaged by the client to undertake an 'onsite wastewater management study' at the above mentioned site address. This report presents the results of that study.

Objective

The objective of the 'onsite wastewater management study' is to investigate the relevant site, soil, public health and economic factors that can impact on the selection, location and design of an on-site wastewater management system to determine:

- Whether or not the site is suitable for an on-site wastewater management system
- The best practical on-site wastewater management system for the specific site and proposed development.

This study has been prepared in accordance with:

- Australian Standard AS1547: 2012 "On-site Domestic Wastewater Management"
- Dept. Local Government 1998, On-site Sewage Management for Single Households,
- Relevant Council Development Control Policies

Scope of Works

The scope of works undertaken for this site evaluation included:

- *Desktop Study:* An initial investigation to collate relevant information about the site and proposed development prior to the site inspection.
- *Site Assessment:* An on-site inspection by an engineer or scientist to record land surface, site features, identify potential site constraints and define the most appropriate land application area.
- *Soil Assessment:* A subsoil investigation by an engineer or scientist to record the soil profile and relevant soil properties within the land application area to determine potential soil limitations.
- *System Design:* An evaluation of the expected wastewater flowrate, site and soil limitations to select, size and position a waste treatment unit and land application system that will provide the best practical option.
- *Operation & Maintenance / Construction & Installation Guidelines*

DESKTOP INFORMATION

<i>Address</i>	<i>Lot 1 West Wilchard Road, CASTLEREAGH, NSW</i>
<i>Council</i>	<i>Penrith City</i>
<i>Proposed Development</i>	<i>Proposed residence</i>
<i>Intended Water Supply Source</i>	<i>Town water</i>
<i>Equivalent Population</i>	<i>Up to 6 people (5 Bedrooms)</i>
<i>Design Wastewater Allowance</i>	<i>150 L / person / day</i>
<i>Design Wastewater Flowrate</i>	<i>900 L / day</i>
<i>Rainfall Station:</i>	<i>067002 – Castlereagh</i>
<i>Evaporation Station:</i>	<i>067021 – Richmond UWS</i>

SITE ASSESSMENT

This following relevant site features were recorded and given a rating in terms of their potential constraints to onsite wastewater management. The three ratings are minor limitation, moderate limitation or major limitation. Only those site features that are rated as being a major limitation to onsite wastewater management are further discussed in the 'Site Assessment Discussion'.

Landform Description

The landform is described by first dividing an area into landform elements of approximately 40-m diameter. A description of these elements is then provided. These landform elements define the boundaries of this site assessment.

<i>Element</i>	<i>Slope Class</i>	<i>Morphological Type</i>	<i>Relative Inclination</i>		<i>Instability Risk</i>
1	Very Gently Inclined	Upper Slope	Waxing	Planar	Low

Vegetation

The vegetation is described by dividing the study area into vegetation elements. Each vegetation element has a unique set of properties.

<i>Element</i>	<i>Growth Form</i>	<i>Height Class</i>	<i>Cover Class</i>	<i>Structural Formation</i>
A	Grass	Low	Dense	Closed Grassland
A	Tree	Tall	Sparse	Woodland

<i>Element</i>	<i>Exposure</i>	<i>Existing Erosion</i>		<i>Landform Element (s)</i>
		<i>State</i>	<i>Type</i>	
A	Fair	Stabilised	-	1
A	Excellent	Stabilised	-	1

Overland Flow

Run-on and run-off potential is largely determined by slope, surface cover and soil infiltration rate.

<i>Landform element.</i>	<i>Run-on</i>	<i>Run-off</i>	<i>Soil - Water Status</i>
1	Very Slow	Very Slow	Moderately Moist

Site & Soil Disturbance

The site assessor noted the following disturbance within the effluent application envelope:

None

Description: -

Rocky Outcrops

The site assessor noted the following rocky-outcrops within the effluent application envelope:

None

Description: -

Setbacks

The following setbacks from the effluent application area have been proposed after considering Appendix R of AS1547:2012 'On-site Domestic Wastewater Management'. This Appendix provides a recent guide on how to determine setbacks distances based on site-specific constraints identified in this site assessment.

The constraint factors associated with each site feature (refer to Table R1) have been qualitatively assessed using Table R2 and a suitable setback then chosen from within the range stated in Table R1.

<i>Site Feature</i>	<i>Setback Range</i>	<i>Constraint Factors</i>	<i>Proposed Setback</i>
Property Boundaries	6 – 12	LOW	6 m
Residence	6 – 12	LOW	12 m Downslope 6 m Upslope
Tree Driplines	1	MODERATE	1 m
Dam/Overland Flows	40	MODERATE	63 m

Site Assessment Discussion

A range of site features that can commonly place limitations on on-site wastewater management have been assessed and classified. All features have been shown to place no major limitations to on-site wastewater management.

Flooding Potential

The AWTS electrical components must stay above the 1:100 year flood level. The dispersal area must stay above the 1:20 year flood level. This is achievable for subject site. For subject site both the AWTS electrics and the dispersal area will be above the 1:100 year flood level. The AWTS electrics will be relying on the area to be filled.

Tree Dripline

In order to establish the setback required some trees or shrubs may need to be cropped or cleared. Clearing may be subject to a vegetation approval.

SOIL ASSESSMENT

The location of the borehole excavated during the site inspection is shown on the attached site plan. Physical and chemical soil properties were recorded on a soil profile log (see attached). On each property two boreholes are performed, the first analyses soil features listed below, and the second serves a confirmatory borehole. If soil properties found in the two boreholes on site differ, then both samples are taken for analysis.

The following properties were recorded for each soil horizon:

- Horizon depth and type
- Mottling
- Colour
- Structural stability
- Groundwater depth
- Bedrock depth
- Texture
- pH
- Phosphorus Sorption
- Electrical Conductivity
- Coarse Fragments

Physical Properties

In summary, the soil profile is described below:

Soil Horizon	Depth	Colour	Mottles	Coarse Fragments %	Texture
A	400	Dark brown	-	< 10	Sandy Loam
B1	1100	Red brown	-	< 10	Sandy Clay Loam
B2	1400	Light brown	-	< 10	Sandy Clay

Excavation terminated at: 1400 mm

Reason: Soil depth is minor limitation

Bedrock Depth: > 1400 mm

Water Table Depth: > 1400 mm

Surface Condition: Firm

Chemical Properties

Soil samples were collected from each major soil horizon and the relevant chemical properties are presented below:

Borehole 1

<i>Horizon</i>	<i>PH</i>	<i>Electrical Conductivity</i> <i>(μS)</i>
A	6.36	81
B1	6.15	39
B2	5.94	56

(Hanna Instruments, HI 98129, Ref 29713)

Phosphorus Adsorption Capacity (kg / ha): 4,000

Erodability / Erosion Hazard

Soil erodability is the susceptibility of the topsoil to detachment and transport of soil particles. It is a characteristic of the soil surface and varies with time, soil / water status and land use. Soil erodability classification is stated as low, moderate or high.

Erosion hazard is the susceptibility of an area of land to the prevailing agents of erosion. It is a function of climate, soil erodability, vegetation cover and topography.

	<i>Borehole 1</i>
<i>Erodability</i>	Low
<i>Erosion Hazard</i>	Slight

Salinity & Drainage

Salinity is the concentration of water-soluble salts contained within a soil. Increases in soil salinity (i.e. salinisation) can occur as a result of irrigation water raising the level of an

already saline groundwater. Management of potential salinisation problems involve ensuring that salts introduced to the soil surface are removed (by crop uptake or subsoil leaching) and by ensuring the irrigation area provides adequate subsoil drainage to prevent raising of saline groundwaters into root zones.

Drainage is a statement describing the site and soil drainage that is likely to occur most of the year. It is influenced by soil permeability, water source, landform description, evapotranspiration, slope gradient and slope length.

The drainage of this site should be adequate for the leaching of salts and ensure the groundwater level does not reach the root zone.

A major adverse effect of high soil salinity is the restrictive effects on plant growth. However, for this site the soil salinity levels (as indicated by the electrical conductivity values) are low enough that the adverse effects on plant growth will be minimal.

Soil Assessment Discussion

A range of soil properties that commonly place limitations on on-site wastewater management have been assessed and classified. In accordance with the Environmental and Health Protection Guidelines all soil properties have been shown to present no major limitations to on-site wastewater management.

ON-SITE WASTEWATER MANAGEMENT SYSTEM DESIGN

The design process adopted here involves an evaluation of the expected wastewater flow, site limitations and soil limitations, to select, size and position a waste treatment unit and land application system that will provide the best practical option.

Wastewater Treatment:

This report proposes that wastewater treatment using a NSW Health accredited (or equivalent) Aerated Wastewater Treatment System (AWTS) as it will produce a high quality effluent produced suitable for irrigation purposes

Effluent Application:

Conventional Piped Absorption Trench

- Reasons
 - Gently to moderately inclined land application area
 - Sufficient soil depth beneath absorption trenches
 - Adequate space available with sufficient buffer distances

Please refer to Appendix H for further detailed irrigation descriptions and standard drawings.

Absorption Trench Sizing Calculations:

Trench Length = Daily Flow / (Trench Width x Design Loading Rate)

Design loading rate = 50 mm / day (DLR value for loams from AS1547)

Daily flow = 900 L/d

Recommended Trench Width = 0.6 m

Total trench length required = 900 / (0.6 x 50)

= 30 m

Assuming each trench is 15 m long (maximum length recommended is 20 m); to provide 30m of trenching, 2 trenches will be required. The spacing between each trench shall be 1000mm (in accordance with AS1547: 2012).

Site Modifications Recommended

100% Reserve Area to be maintained.

RECOMMENDATIONS

- Installation of a NSW Health accredited Aerated Wastewater Treatment System (AWTS) with capacity to treat the design flowrate (900 L/d) to a secondary treatment standard with disinfection.
- Installation of 30 m of piped absorption trenching (2 trenches at 15 m long each), with a width of 600 mm and spacing between trenches of 1000 mm.
- Please refer to Appendix H for further detailed beds and trenches descriptions and standard drawings for guidance during construction and installation.
- Each irrigation system must be installed within the proposed land application area shown on the site plan or within the 'available effluent disposal envelope' (if an envelope is shown on your site plan).
- Fit "full water-reduction facilities" to all water use outlets in the house:
 - Reduced flush 6/3 litre water closets,
 - Front-load washing machines,
 - Flow/pressure control valves on water-use outlets (9L/min maximum)
 - Aerator faucets,
 - Shower-flow restrictors
- The absorption trenches shall be maintained in accordance with the attached "Operation and Maintenance Guidelines" (Appendix F).
- The setbacks between the proposed land application area and site features should be adhered to.
- 100% Reserve Area to be maintained.

LIMITATIONS

Envirotech Pty Ltd has prepared this report for the exclusive use of our client, for this project only and for the purpose(s) described in the report. It should not be used for other projects or by a third party. Any party so relying upon this report beyond its exclusive use and purpose as stated above, and without the express written consent of Envirotech, does so entirely at its own risk and without recourse to Envirotech for any loss or damage.

In preparing this report Envirotech has necessarily relied upon information provided by the client and/or their Agents. The results provided in the report are indicative of the sub-surface conditions only at the specific sampling or testing locations, and then only to the depths investigated and at the time the work was carried out. Under no circumstances can it be considered that these findings represent the actual state of the site at all points. Subsurface conditions can change abruptly due to variable geological processes and also as a result of anthropogenic influences. Such changes may occur after Envirotech's field testing has been completed.

Envirotech's advice is based upon the conditions encountered during this investigation. The accuracy of the advice provided by Envirotech in this report may be limited by undetected variations in ground conditions between sampling locations. The advice may also be limited by budget constraints imposed by others or by site accessibility.

Should any site conditions be encountered during construction that vary significantly from those outlined and discussed in this report, Envirotech should be advised and a plan outlining the need for potential action developed accordingly.

This report must be read in conjunction with all of the attached notes and should be kept in its entirety without separation of individual pages or sections. Envirotech cannot be held responsible for interpretations or conclusions made by others unless they are supported by an expressed statement, interpretation, outcome or conclusion given in this report.

This report, or sections from this report, should not be used as part of a specification for a project, without review and agreement by Envirotech. This is because this report has been written as advice and opinion rather than instructions for construction.

QDO 035-3
AWTS & Irrigation

Release Date: 16/04/2015
Approved By: Daniel Mathew



<p>Environmental and Engineering Consultancy Services</p>	Legend		
	<ul style="list-style-type: none"> - Site Boundary - Other Fences - Landmark Elements - Watercourse, Ditch - Overland Flow Path - Surface Spray Sprinkler - Irrigation Dripper - Soil Borehole - Photo Location - APZ Line - Land App. Area - Paved Area 		
	AWTS + Trenches		
	Keller	Date 10/09/2015	Scale 1:600
Lot 1 West Wilchard Road, CASTLEREAGH			
DWG-235615-A		Sheet 1/1	

ON-SITE SEWAGE MANAGEMENT SYSTEMS

You live in or rent a house that is not connected to the main sewer then chances are that your yard contains an on-site sewage management system. If this is the case then you have a special responsibility to ensure that it is working as well as you can.

The aim of this pamphlet is to introduce you to some of the most popular types of on-site sewage management systems and provide some general information to help you maintain your system effectively. You should find out what type of system you have and how it works.

More information can be obtained from the pamphlets:

- Your Septic System
- Your Aerated Wastewater Treatment System
- Your Composting Toilet
- Your Land Application Area

You can get a copy of these pamphlets from your local council or the address marked on the back of this pamphlet.

It is important to keep in mind that maintenance needs to be performed properly and regularly. Poorly maintained on-site sewage management systems can significantly affect you and your family's health as well as the local environment.

What is an on-site sewage management system?

A domestic on-site sewage management system is made up of various components which - if properly designed, installed and maintained - allow the treatment and utilisation of wastewater from a house, completely within the boundary of the property.

Wastewater may be blackwater (toilet waste), or greywater (water from showers, sinks, and washing machines), or a combination of both.

Partial on-site systems - eg, pump out and common effluent systems (CES) - also exist. These usually involve the preliminary on-site treatment of wastewater in a septic tank, followed by collection and transport of the treated wastewater to an off-site management facility. Pump out systems use road tankers to transport the effluent, and CES use a network of small diameter pipes.

How does an on-site sewage management system work?

For complete on-site systems there are two main processes:

1. treatment of wastewater to a certain standard
2. its application to a dedicated area of land.

The type of application permitted depends on the quality of treatment, although you should try to avoid contact with all treated and untreated wastewater, and thoroughly wash affected areas if contact does occur.

Treatment and application can be carried out using various methods:

Septic Tank

Septic tanks treat both greywater and blackwater, but they provide only limited treatment through the settling of solids and the flotation of fats and greases. Bacteria in the tank break down the solids over a period of time. Wastewater that has been treated in a septic tank can only be applied to land through a covered soil absorption system, as the effluent is still too contaminated for above ground or near surface irrigation.

AWTS

Aerated wastewater treatment systems (AWTS) treat all household wastewater and have several treatment compartments. The first is like a septic tank, but in the second compartment air is mixed with the wastewater to assist bacteria to break down solids. A third compartment allows settling of more solids and a final chlorination contact chamber allows disinfection. Some AWTS are constructed with all the compartments inside a single tank. The effluent produced may be surface or sub-surface irrigated in a dedicated area.

Composting Toilets

Composting toilets collect and treat toilet waste only. Water from the shower, sinks and the washing machine needs to be treated separately (for example in a septic tank or AWTS as above). The compost produced by a composting toilet has special requirements but is usually buried on-site.

These are just some of the treatment and application methods available, and there are many other types such as sand filter beds, wetlands, and amended earth mounds. Your local council or the NSW Department of Health have more information on these systems if you need it.

Regulations and recommendations

The NSW Department of Health determines the design and structural requirements for treatment systems for single households. Local councils are primarily responsible for approving the installation of smaller domestic septic tank systems, composting toilets and AWTS in their area, and are also responsible for approving land application areas. The NSW Environment Protection Authority approves larger systems.

The design and installation of on-site sewage management systems, including plumbing and drainage, should only be carried out by suitably qualified or experienced people. Care is needed to ensure correct sizing of the treatment system and application area.

Heavy fines may be imposed under the Clear Waters Act if wastewater is not managed properly.

Keeping your on-site sewage management system operating well

What you put down your drains and toilets has a lot to do with how well your system performs. Maintenance of your sewage management system also needs to be done well and on-time. The following is a guide to the types of things you should and should not do with your system.

Managing Wastewater In Your Backyard

Reducing water usage
 Reducing water usage will lessen the likelihood of problems such as overloading with your septic system. Overloading may result in wastewater backing up into your house, contamination of your yard with improperly treated effluent, and effluent from your system contaminating groundwater or a nearby waterway.

Your sewage management system is also unable to cope with large volumes of water such as several showers or loads of washing over a short period of time. You should try to avoid these 'shock loads' by ensuring water use is spread more evenly throughout the day and week.

HELP PROTECT YOUR HEALTH AND THE ENVIRONMENT

Poorly maintained sewage management systems are a serious source of water pollution and may present health risks, cause odours and attract vermin and insects.

By looking after your management system you can do your part in helping to protect the environment and the health of you and your community.

For more information please contact:

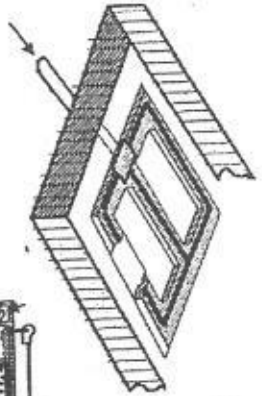
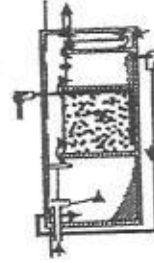
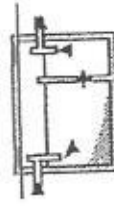

DO

- ✓ Learn how your sewage management system works and its operational and maintenance requirements.
- ✓ Learn the location and layout of your sewage management system.
- ✓ Have your AWTS (if installed) inspected and serviced four times per year by an approved contractor. Other systems should be inspected at least once every year. Assessment should be applicable to the system design.
- ✓ Keep a record of desludgings, inspections, and other maintenance.
- ✓ Have your septic tank or AWTS desludged every three years to prevent sludge build up, which may 'clog' the pipes.
- ✓ Conserve water. Conservative water use around the house will reduce the amount of wastewater which is produced and needs to be treated.
- ✓ Discuss with your local council the adequacy of your existing sewage management system if you are considering house extensions for increased occupancy.

DON'T

- ✗ Don't let children or pets play on land application areas.
- ✗ Don't water fruit and vegetables with effluent.
- ✗ Don't extract untreated groundwater for cooking and drinking.
- ✗ Don't put large quantities of bleaches, disinfectants, whiteners, nappy soakers and spot removers into your system via the sink, washing machine or toilet.
- ✗ Don't allow any foreign materials such as nappies, sanitary napkins, condoms and other hygiene products to enter the system.
- ✗ Don't put fats and oils down the drain and keep food waste out of your system.
- ✗ Don't install or use a garbage grinder or spa bath if your system is not designed for it.

Aerated Wastewater Treatment Systems (AWTS)

In unsewered areas, the proper treatment and utilisation of household wastewater on-site is critical in preserving the health of the public and the environment. AWTS have been developed as a way of achieving this.

What is an AWTS?

An AWTS is a purpose built system used for the treatment of sewage and liquid wastes from a single household or multiple dwellings.

It consists of a series of treatment chambers combined with an irrigation system. An AWTS enables people living in unsewered areas to treat and utilise their wastewater.

How does an AWTS work?

Wastewater from a household is treated in stages in several separate chambers. The first chamber is similar to a conventional septic tank. The wastewater enters the chamber where the solids settle to the bottom and are retained in the tank forming a sludge layer. Scum collects at the top, and the partially clarified wastewater flows into a second chamber. Here the wastewater is mixed with air

to assist bacteria to further treat it. A third chamber allows additional clarification through the settling of solids, which are returned for further treatment to either the septic chamber (as shown) or to the aeration chamber. The clarified effluent is disinfected in another chamber (usually by chlorination) before irrigation can take place.

Bacteria in the first chamber break down the solid matter in the sludge and scum layers. Material that cannot be fully broken down gradually builds up in the chamber and must be pumped out periodically.

Regulations and recommendations

Local councils are primarily responsible for approving the smaller, domestic AWTSs in their area. The Environment Protection Authority (EPA) approves larger units, whilst the NSW Department of Health determines the design and structural requirements for all AWTSs.

At present AWTSs need to be serviced quarterly by an approved contractor at a cost to the owner. Local councils should also maintain a register of the servicing of each system within their area.

AWTSs should be fitted with an alarm having visual and audible components to indicate mechanical and electrical equipment malfunctions. The alarm should provide a signal adjacent to the alarm and at a relevant position inside the house. The alarm should incorporate a warning lamp which may only be reset by the service agent.

Maintaining your AWTS

The effectiveness of the system will, in part, depend on how it is used and maintained. The following is a guide on good maintenance procedures that you should follow:

- DO**
- ✓ Have your AWTS inspected and serviced four times per year by an approved contractor. Assessment should be applicable to the system design.
 - ✓ Have your system service include assessment of sludge and scum levels in all tanks, and performance of irrigation areas.
 - ✓ Have all your tanks desludged at least every three years.
 - ✓ Have your disinfection chamber inspected and tested quarterly to ensure correct disinfectant levels.
 - ✓ Have your grease trap (if installed) cleaned out at least every two months.
 - ✓ Keep a record of pumping, inspections, and other maintenance.
 - ✓ Learn the location and layout of your AWTS and land application area.
 - ✓ Use biodegradable liquid detergents such as concentrates with low sodium and phosphorous levels.
 - ✓ Conserve water.
- DON'T**
- ✗ Don't put bleaches, disinfectants, whiteners, nappy soakers and spot removers in large quantities into your AWTS via the sink, washing machine or toilet.
 - ✗ Don't allow any foreign materials such as nappies, sanitary napkins, condoms and other hygiene products to enter the system.
 - ✗ Don't use more than the recommended amounts of detergents.
 - ✗ Don't put fats and oils down the drain and keep food waste out of your system.
 - ✗ Don't switch off power to the AWTS, even if you are going on holidays

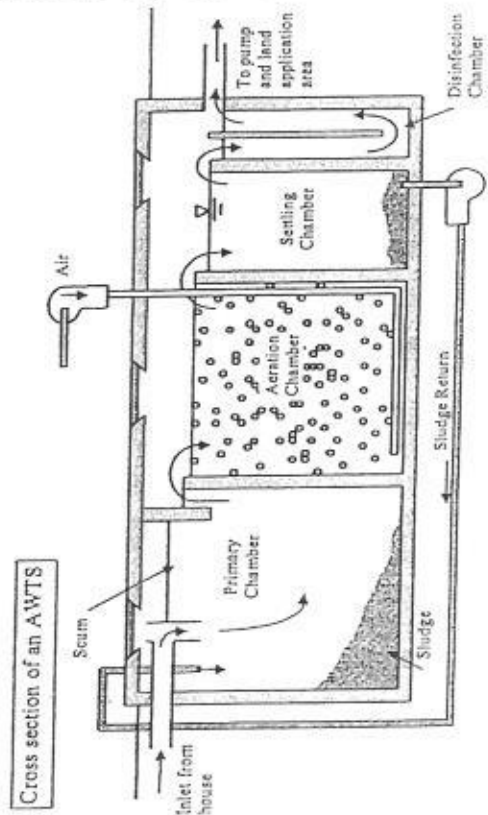

Reducing water usage

Reducing water usage will lessen the likelihood of problems such as overloading with your AWTS. Overloading may result in wastewater backing up into your house, contamination of your yard with improperly treated effluent, and effluent from your system entering a nearby river, creek or dam.

Conservative water use around the house will reduce the amount of wastewater which is produced and needs to be treated.

Your AWTS is also unable to cope with large volumes of water such as several showers or loads of washing over a short period of time. You should try to avoid these 'shock loads' by ensuring water use is spread more evenly throughout the day and week.

Warning signs

You can look out for a few warning signs that signal to you that there are troubles with your AWTS. Ensure that these problems are attended to immediately to protect your health and the environment.

Look out for the following warning signs:

- ⊖ Water that drains too slowly.
- ⊖ Drain pipes that gurgle or make noises when air bubbles are forced back through the system.
- ⊖ Sewage smells, this indicates a serious problem.
- ⊖ Water backing up into your sink which may indicate that your system is already failing.
- ⊖ Wastewater pooling over the land application area.
- ⊖ Black coloured effluent in the aerated tank.
- ⊖ Excess noise from the blower or pumping equipment
- ⊖ Poor vegetation growth in irrigated area.

Odour problems from a vent on the AWTS can be a result of slow or inadequate breakdown of solids. Call a technician to service the system.

HELP PROTECT YOUR HEALTH AND THE ENVIRONMENT

Poorly maintained AWTSs are a serious source of water pollution and may present health risks, cause odours and attract vermin and insects.

By looking after your treatment system you can do your part in helping to protect the environment and the health of you and your family.

Your Aerated Wastewater Treatment System

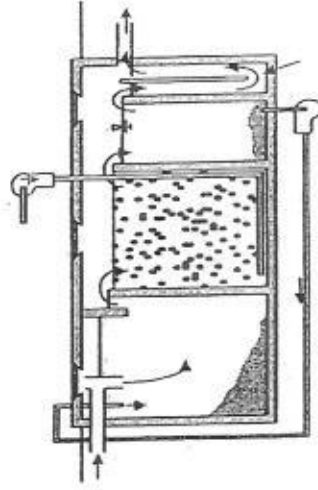

LAND APPLICATION AREAS

The reuse of domestic wastewater on-site can be an economical and environmentally sound use of resources.

What are land application areas?

These are areas that allow treated domestic wastewater to be managed entirely on-site.

The area must be able to utilise the wastewater and treat any organic matter and wastes it may contain. The wastewater is rich in nutrients, and can provide excellent nourishment for flower gardens, lawns, certain shrubs and trees. The vegetation should be suitably tolerant of high water and nutrient loads.

How does a land application area work?

Treated wastewater applied to a land application area may be utilised or simply disposed, depending on the type of application system that is used. The application of the wastewater can be through a soil absorption system (based on disposal) or through an irrigation system (based on utilisation).

Soil absorption systems do not require highly treated effluent, and wastewater treated by a septic tank is reasonable as the solids content in the effluent has been reduced. Absorption systems release the effluent into the soil at a depth that cannot be reached by the roots of most small shrubs and grasses. They rely mainly on the processes of soil treatment and then transmission to the water table, with minimal evaporation and up-take by plants. **These systems are not recommended in sensitive areas as they may lead to contamination of surface water and groundwater.**

Irrigation systems may be classed as either subsurface or surface irrigation. If an irrigation system is to be used, wastewater needs to be pre-treated to at least the quality produced by an aerated wastewater treatment system (AWTS).

Subsurface irrigation requires highly treated effluent that is introduced into the soil close to the surface. The effluent is utilised mainly by plants and evaporation.

Surface irrigation requires highly treated effluent that has undergone aeration and disinfection treatments, so as to reduce the possibility of bacteria and virus contamination.

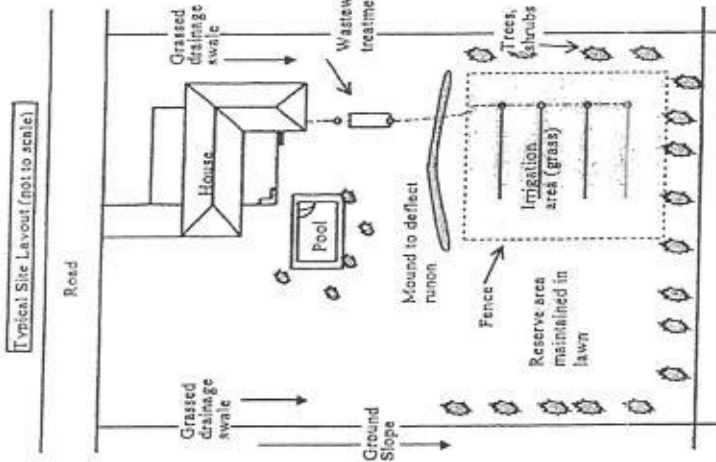

The effluent is then applied to the land area through a series of drip, trickle, or spray points which are designed to eliminate airborne drift and run-off into neighbouring properties.

There are some public health and environmental concerns about surface irrigation. There is the risk of contact with treated effluent and the potential for surface run-off. Given these problems, subsurface irrigation is arguably the safest, most efficient and effective method of effluent utilisation.

Regulations and recommendations

The design and installation of land application areas should only be carried out by suitably qualified or experienced people, and only after a site and soil evaluation is done by a soil scientist. Care should be

taken to ensure correct buffer distances are left between the application area and bores, waterways, buildings, and neighbouring properties.

Heavy fines may be imposed under the Clean Waters Act if effluent is managed improperly.

At least two warning signs should be installed along the boundary of a land application area. The signs should comprise of 20mm high Series C lettering in black or white on a green background with the words:

RECLAIMED EFFLUENT
NOT FOR DRINKING
AVOID CONTACT

Depending on the requirements of your local council, wet weather storage and soil moisture sensors may need to be installed to ensure that effluent is only irrigated when the soil is not saturated.

Regular checks should be undertaken of any mechanical equipment to ensure that it is operating correctly. Local councils may require periodic analysis of soil or groundwater characteristics

Humans and animals should be excluded from land application areas during and immediately after the application of treated wastewater. The longer the period of exclusion from an area, the lower the risk to public health.

The householder is required to enter into a service contract with the installation company, its agent or the manufacturer of their sewage management system, this will ensure that the system operates efficiently.

Location of the application area

Treated wastewater has the potential to have negative impacts on public health and the environment. For this reason the application area must be located in accordance with the results of a site evaluation, and approved landscaping must be completed prior to occupation of the building. Sandy soil and clayey soils may present special problems.

The system must allow even distribution of treated wastewater over the land application area.

Maintaining your land application area

The effectiveness of the application area is governed by the activities of the owner.

DO

- ✓ Construct and maintain diversion drains around the top side of the application area to divert surface water.
- ✓ Ensure that your application area is kept level by filling any depressions with good quality top soil (not clay).
- ✓ Keep the grass regularly mowed and plant small trees around the perimeter to aid absorption and transpiration of the effluent.
- ✓ Ensure that any run off from the roof, driveway and other impermeable surfaces is directed away from the application area.
- ✓ Fence irrigation areas.
- ✓ Ensure appropriate warning signs are visible at all times in the vicinity of a spray irrigation area.
- ✓ Have your irrigation system checked by the service agent when they are carrying out service on the treatment system.

DON'T

- ✗ Don't erect any structures, construct paths, graze animals or drive over the land application area.
- ✗ Don't plant large trees that shade the land application area, as the area needs sunlight to aid in the evaporation and transpiration of the effluent.
- ✗ Don't plant trees or shrubs near or on house drains.
- ✗ Don't alter stormwater lines to discharge into or near the land application area.
- ✗ Don't flood the land application area through the use of hoses or sprinklers.
- ✗ Don't let children or pets play on land application areas.
- ✗ Don't water fruit and vegetables with the effluent.
- ✗ Don't extract untreated groundwater for potable use.

Warning signs

Regular visual checking of the system will ensure that problems are located and fixed early.

The visual signs of system failure include:

- ⊖ surface ponding and run-off of treated wastewater
- ⊖ soil quality deterioration
- ⊖ poor vegetation growth
- ⊖ unusual odours

Volume of water

Land application areas and systems for on-site application are designed and constructed in anticipation of the volume of waste to be discharged. Uncontrolled use of water may lead to poorly treated effluent being released from the system.

If the land application area is waterlogged and soggy the following are possible reasons:

- ⚠ Overloading the treatment system with wastewater.
- ⚠ The clogging of the trench with solids not trapped by the septic tank. The tank may require desludging.
- ⚠ The application area has been poorly designed.
- ⚠ Stormwater is running onto the area.

HELP PROTECT YOUR HEALTH AND THE ENVIRONMENT

Poorly maintained land application areas are a serious source of water pollution and may present health risks, cause odours and attract vermin and insects.

By looking after your sewage management system you can do your part in helping to protect the environment and the health of you and your family.

Your Land Application Area

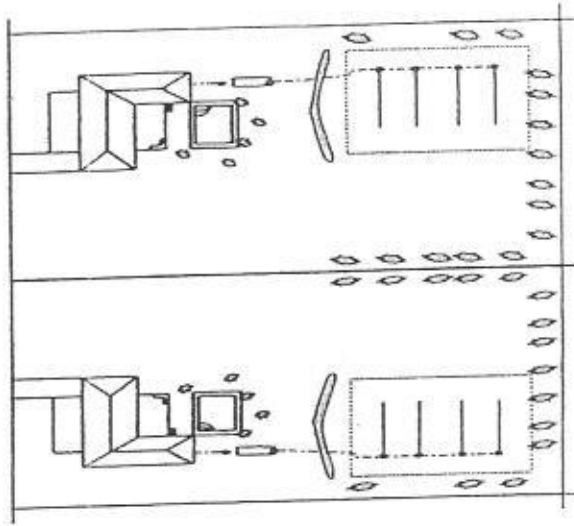

APPENDIX G: WATER CONSERVATION

Whilst this report is based on AA rated plumbing fixtures, AA rated plumbing would further conserve limited water supplies and enhance performance of the irrigation, soil and plant systems. Water saving devices will reduce the volume of water that needs to be applied to the site, and thus reduce the risk of any runoff.

Using the following water saving devices, the average household's water consumption can be reduced from 900 litres to 750 litres per day:

- Dual flush 6/3 litre pan and cistern (average household savings of 93 L/day) *
- AAA rated shower heads to limit flows to 7 L/minute *
- AAA rated dishwasher (not more than 18 litres for each wash cycle) **
- AAA rated washing machine (not more than 22 litres per dry kg of clothes) **

* Source: Independent Pricing and Regulation Tribunal of NSW (1996), Water Demand Management: A Framework for Option Assessment

** Source: Sydney Water Demand Management Strategy, October 1995

Low phosphate, low sodium detergents are recommended to help improve the effluent quality. Low sodium detergents ensure that the soil structure, and hence its absorption capacity, is maintained as close as possible to a natural condition. Sodium in laundry powders is used as a filler. Therefore, in general, liquid detergents are preferred over powder. Low phosphorus detergents ensure that optimum plant growth is maintained and that excess phosphorus is not leached into the environment.

Bleaches, disinfectants and other cleaning compounds can harm wastewater treatment systems, such as septic tanks, because they kill bacteria that colonise the system and help treat wastewater. Use these products sparingly and always check that they are safe for septic systems. Avoid placing oil, paint, petrol, acids, degreasers, photography chemicals, cosmetics, lotions, pesticides and herbicides in the wastewater system. Even small amounts of these products can harm the performance of the onsite effluent management system.

Appendix H: Beds & Trenches Descriptions & Standard Drawings

Absorption Trenches

Australian Standard AS1547:2000 provides design criteria that should be reviewed by the installer. Trenches shall be constructed having a depth of 600mm with a depth of 600mm, lined with a 300mm radius half rounded plastic drain or similar. The drain shall then be encased with a 10mm aggregate to a level of 500mm, with a topsoil of 100mm being placed to existing surface level. Trenches are normally limited to a maximum of 20m in length to ensure even distribution of effluent along their base. An exception to this would be if they were pressure dosed from an AWTS or pump well.

Effluent flows must be distributed evenly to trenches by the use of a distribution box with "V" weirs or similar. In some cases, parallel trenches may be joined cascade fashion so that overflow from one trench flows downslope to the next.

If dosed with septic effluent it is important that the trenches are protected from clogging by the use of a septic outlet filter.

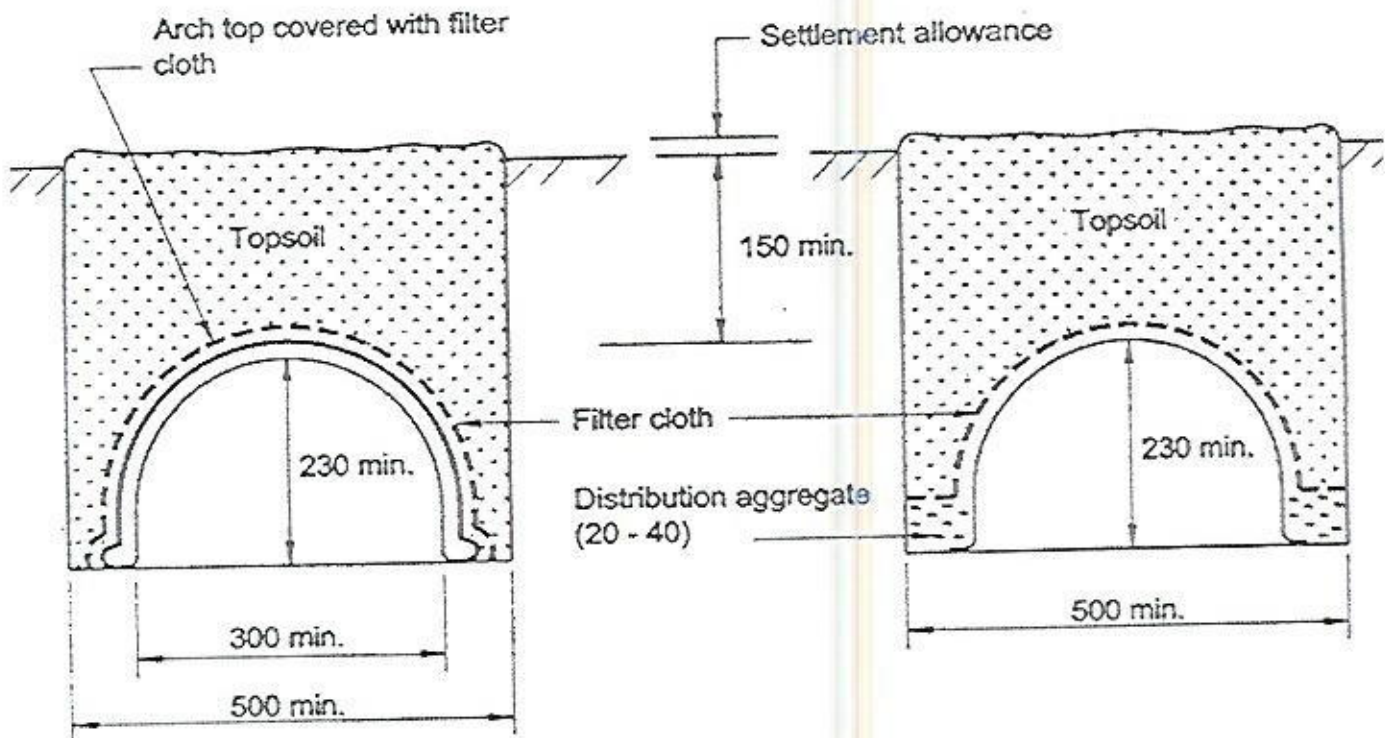

Evapotranspiration Absorption (ETA) Beds

Typical cross sections of an ETA land application area are shown in the figures below. A qualified plumber familiar with the requirements for constructing ETA beds should be employed for building this system.

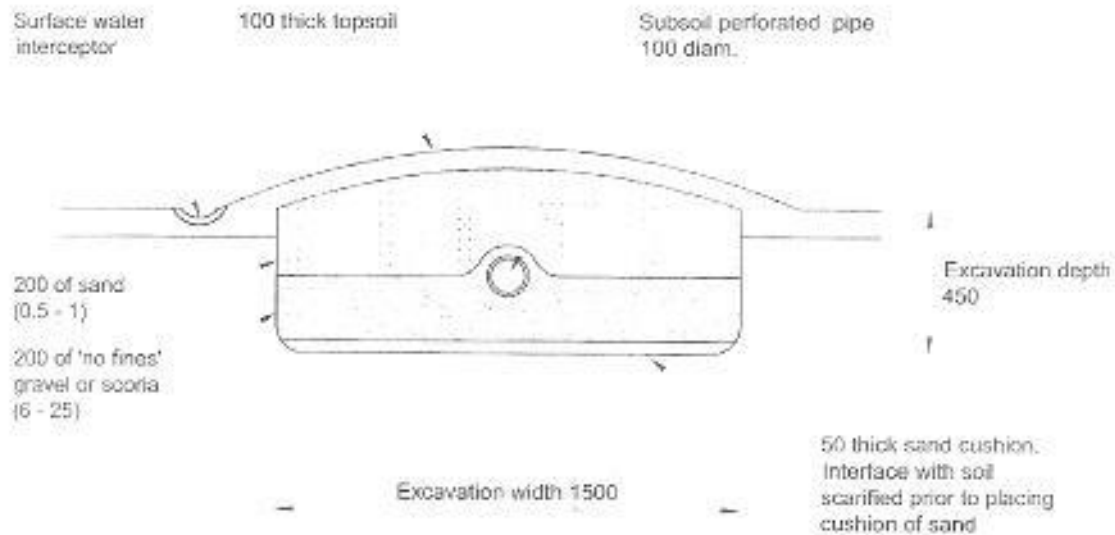

Conventional ETA BED

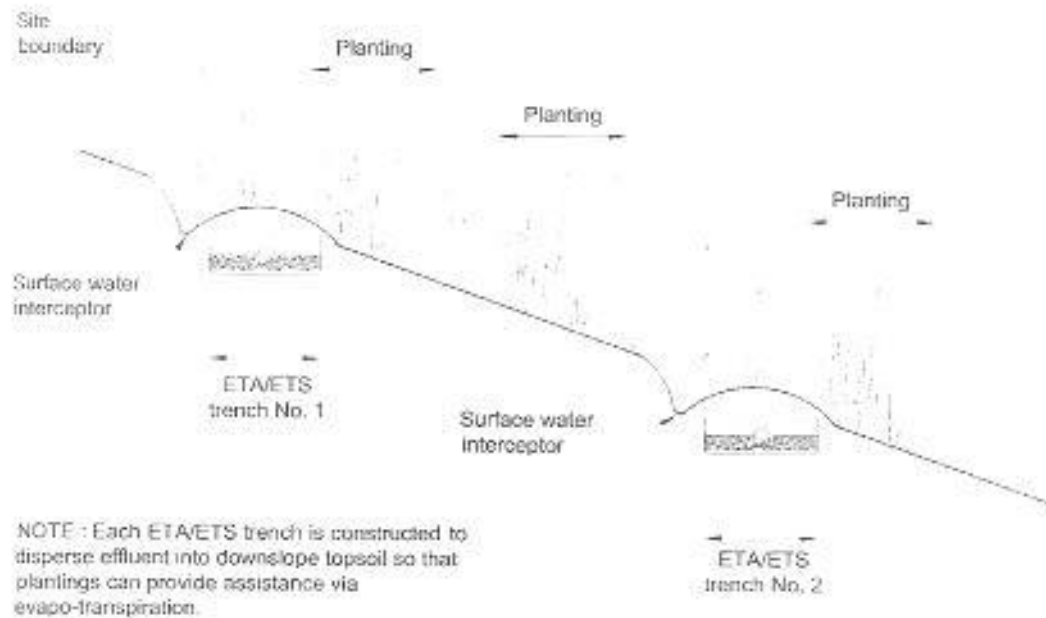

Narrow ETA Beds on Sloped Ground

Some general considerations follow:

- **Good Construction Techniques:**

1) *Excavation:*

- a) Excavation shall not damage the soil by:
 - *Smearing:* where the soil is smoothed; filling cracks and pores.
 - *Compacting:* where the soil porosity is reduced.
 - *Puddling:* where washed clay settles on the base of the bed form a relatively impermeable layer.
- Note:* cohesive soils, or soils containing a significant quantity of clay, are susceptible to damage by excavation equipment during construction.
- b) The spacing between individual ETA beds shall be not less than 1000-mm. Individual bed length shall be limited to around 20 m. The total bed length requirement shall be divided into approximately equal individual bed lengths.
 - c) Plan to excavate only when the weather is fine.
 - d) During wet seasons or when construction cannot be delayed until the weather becomes fine, smeared soil surfaces may be raked to reinstate a more natural soil surface.
 - e) When excavating by machine, fit the bucket with 'raker teeth' if possible.
 - f) Avoid compaction by keeping people off the finished bed floor.
 - g) If rain is forecast then cover any open beds to protect them from rain damage.
 - h) Excavate perpendicular to the line of fall or parallel to the contour of sloping ground.
 - i) Ensure that the bed inverts are horizontal.

2) *Pipe Laying*

- a) A distribution box (or header) shall ensure even flow to each individual bed.
- b) Effluent shall be distributed through perforated pipe laid parallel with the horizontal bottom of the bed. The minimum internal diameter of the pipe shall be not less than 80 mm.

3) *Pre-Commissioning Test:*

- a) A pre-commissioning test may be carried-out on pump-dosed systems after all on-site components, including a pump, have been installed but prior to backfilling the effluent-distribution system in the bed:

Steps:

- 1) Fill pump to 'pump-on' level with potable water;
- 2) Start pump;
- 3) Check effluent distribution pipework to ensure water flows uniformly from all perforations;
- 4) Record time taken to pump from 'pump-on' level to the 'pump-off' level. This shall be approximately 3 minutes.
- 5) Follow pump manufacturer's recommendations for commissioning pump;
- 6) Check pumping main to ensure there are no leaks and that the air-release valve is functioning;
- 7) Check that the high-water level alarm operates.

4) *ETA Bed Backfilling:*

After installation of pipe-work, and any pre-commissioning tests undertaken, the distribution aggregate shall be carefully placed into each bed. This is done so as to avoid damage to the bed floor, sidewalls and the pipe-work. The ETA profile must be:

- 50mm of sand
- 200mm of 'no fines' gravel
- A length of subsoil perforated pipe (100mm diameter)
- A layer of non-woven geo-textile
- 200mm of sand
- 100mm of topsoil high in organic material
- Dense grassland by seeding or turf

The finished form should be mounded in cross-section to promote runoff of incident rainfall and to allow for settling. Surface water shall be diverted around the perimeter and up-slope of the land-application area. Rainfall shall be shed from the mounded surface of the ETA beds.

SEPTIC SYSTEMS

In unsewered areas, the proper treatment and reuse of household wastewater on-site is critical in ensuring minimal impact to public health and the environment. Septic systems have been developed as a way of achieving this.

What is a septic system?

A septic system consists of a septic tank combined with a soil absorption system and/or transpiration beds or pump out connections. The system enables people living in unsewered areas to treat and disperse their sewage.

A septic tank is a structurally sound watertight tank used for the treatment of sewage and liquid wastes from a single household or multiple dwellings.

How does a septic system work?

All the wastewater from a household enters the tank. Most of the solids settle to the bottom and are retained in the tank forming a sludge layer, whilst fats and greases collect at the top in a scum layer.

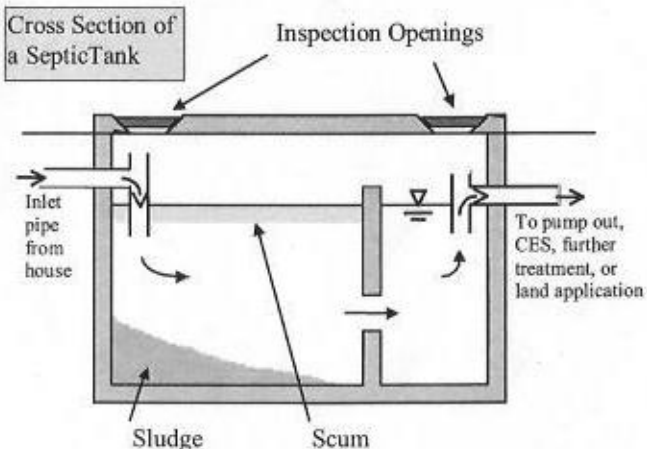

Bacteria in the septic tank break down the solid matter in the sludge and scum layers. Material that cannot be fully broken down gradually builds up in the tank and must be pumped out periodically.

There are three ways to handle septic tank effluent:

On-site application. The effluent flows from the septic tank to transpiration and/or absorption trenches. Here the effluent is mainly absorbed into the soil and partly evaporated by the sun and used by vegetation.

Such application systems have the potential to contaminate groundwater and are not recommended in sensitive locations or in higher density developments. Further treatment followed by subsurface irrigation should be considered.

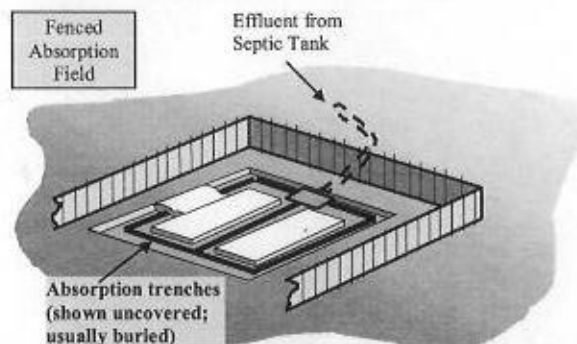

Pump out. The effluent flows from the septic tank into a collection well or holding tank. At regular periods, a tanker pumps out the holding tank and transports the effluent to an off-site management facility.

Common effluent system (CES). The treated wastewater is transported to an off-site management facility through a network of small diameter pipes.

Regulations and recommendations

An on-site septic system requires approval from the local council before it is put in place. The regulations that apply to single household systems differ from those for multiple dwellings. The Environment Protection Authority (EPA) is responsible for approving septic tanks used to treat wastes generated by multiple dwellings like caravan parks and commercial and industrial premises. The NSW Department of Health determines the design and structural requirements for septic tanks and collection wells.

Local councils have the authority to approve systems certified by the NSW Department of Health for individual properties and ensure the systems do not have adverse impacts on health and the environment. Local councils are responsible for ensuring that the approved system is installed according to specifications and any special conditions, and is maintained and serviced correctly. You should consult your local council on the regulations that apply to you.

Care of the septic tank is only a part of the maintenance of your septic system. Management of the treated wastewater from your septic system is your responsibility and is discussed in the pamphlet "Your Land Application Area". Heavy fines may be imposed if the effluent is managed improperly.

Maintaining your septic system

The effectiveness of the system will, in part, depend on how it is operated and maintained. The following is a guide on how to achieve the most from your system.

DO

- ✓ Have your septic tank desludged every three years to prevent sludge build up, which may 'clog' the pipes and absorption trenches.
- ✓ Have your septic tank serviced annually by contractors to check scum and sludge levels, and the presence of blockages in the outlet and inlet pipes.
- ✓ Have your grease trap (if installed) cleaned out at least every two months.
- ✓ Keep a record of pumping, inspections, and other maintenance.
- ✓ Learn the location and layout of your septic system and land application area.
- ✓ Check household products for suitability for use with a septic tank.
- ✓ Use biodegradable liquid detergents, such as concentrates with low phosphorous.
- ✓ Ensure your tank is mosquito-proofed.
- ✓ Conserve water.

DON'T

- ✗ Don't put large quantities of bleaches, disinfectants, whiteners, nappy soakers and spot removers into your septic tank via the sink, washing machine or toilet.
- ✗ Don't allow any foreign materials such as nappies, sanitary napkins, condoms and other hygiene products to enter the system.
- ✗ Don't use more than the recommended amounts of detergents.
- ✗ Don't put fats and oils down the drain and keep food waste out of your system.
- ✗ Don't install or use a garbage grinder or spa bath if your system is not designed for it.

Reducing water usage

Reducing water usage will lessen the likelihood of problems such as overloading with your septic system. Overloading may result in wastewater backing up into your house, contamination of your yard with improperly treated effluent, and effluent from your system contaminating groundwater or a nearby river, creek or dam.

Conservative water use around the house will reduce the amount of wastewater which is produced and needs to be treated.

Your septic system is also unable to cope with large volumes of water such as several showers or loads of washing over a short period of time. You should try to avoid these 'shock loads' by ensuring water use is spread more evenly throughout the day and week.

Warning signs

You can look out for a few warning signs that signal to you that there are troubles with your septic tank. Ensure that these problems are attended to immediately to protect your health and the environment.

Look out for the following warning signs:

- ⚠ Water that drains too slowly.
- ⚠ Drain pipes that gurgle or make noises when air bubbles are forced back through the system.
- ⚠ Sewage smells, this indicates a serious problem.
- ⚠ Water backing up into your sink which may indicate that your septic system is already failing.
- ⚠ Wastewater surfacing over the land application area.

Trouble shooting guide

If there are odours check the following areas:

- ⚠ Greasetrap (if installed), is it full or blocked?
- ⚠ Absorption field, is it wet or soggy?
- ⚠ Has there been recent heavy rain?

Odour problems from a vent on the septic system can be a result of slow or inadequate breakdown of solids. Call a technician to service the system.

HELP PROTECT YOUR HEALTH AND THE ENVIRONMENT

Poorly maintained septic tanks are a serious source of water pollution and may present health risks, cause odours and attract vermin and insects.

By looking after your septic system you can do your part in helping to protect the environment and the health of you and your family.

If you would like more information please contact:

Your Septic System

