

LEGEND

- turf  
Excavate / grade all areas to be turfed to 120mm below required finished levels. Do not excavate within 1500mm of the trunk of any existing tree to be retained. Ensure that all surface water runoff is directed towards inlet pits, kerbs etc. and away from buildings. Ensure that no ponding will occur. Rip the subgrade to 150mm. Install 100mm depth of imported topsoil. Just prior to spreading the turf, spread "Shirley's No. 17 lawn fertilizer" over the topsoil at the recommended rate. Lay "Kikuyu" turf rolls closely butted. Fill and small gaps with topsoil. Water thoroughly.
  - brick garden edging  
Lay a single course of paving bricks in a mortar haunch (200mm wide and 100mm deep). The edges are to be laid in even curves and straight lines as shown on the plan. Where tight curves are shown use half bricks to show a more even curve. The top of the edges to finish flush with the adjacent turf and mulch levels.
  - existing trees to be removed
  - existing trees to be retained
  - stepping stones  
Precast concrete stepping stones in decorative gravel mulch
  - planting areas  
Ensure that the mass planting areas have been excavated to 300mm below finished levels. Rip to a further depth of 150mm. Supply and install 300mm soil mix. Soil mix to comprise of one part approved compost to three parts topsoil. Topsoil shall be either imported topsoil or stockpiled site topsoil (if suitable i.e. No clay). Install 75mm depth of selected mulch.
- maintenance:**  
All landscape works are to be maintained for a period of three months from the date of practical completion. This includes all watering, weeding, spraying and re-mulching necessary to achieve vigorous growth. Any defects which arise during this period are to be rectified immediately. Any plants or areas of turf which fall during this period are to be replaced at no additional cost.
- fencing:**  
For all fencing types and materials refer to the Architects plans.

NOTE: DO NOT EXCAVATE FOR GARDEN BED UNDER BATH EXISTING IRONBARK. PLANTS TO BE PLANTED IN INDIVIDUALLY HAND DUG HOLES

NOTES:  
FOR PLANT SCHEDULE AND DETAILS REFER TO DRAWING NO. L-02

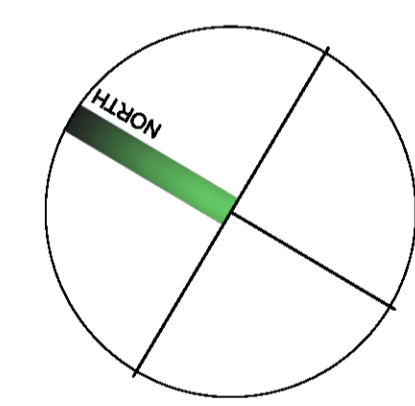

05.07.21 Rev DA to include new bin store and bus shelter B  
09.12.20 DA Issue A  
DATE AMENDMENT ISSUE

**RFA** RAY FUGGLE ASSOCIATES  
landscape architects  
18 NEW FARM ROAD WEST PENNANT HILLS NSW 2125  
email: RAY@fuggle.net.au m 0412 294 712  
a b n 18 003 773 639

Project:  
**PROPOSED SENIORS HOUSING DEVELOPMENT**  
No. 103-109 Laycock Street,  
**CRANEBROOK**

Client:  
**Mr F. CATANEA**

Drawing Title:  
**LANDSCAPE PLAN**

Issue:	rev. DA	date:	05/07/21	Issue no:	B
file name:	c:\			drawing No:	
drawn:	HK	scale:	1:100 @ A1		
checked:	RF	project No:	4527c		L-01/4



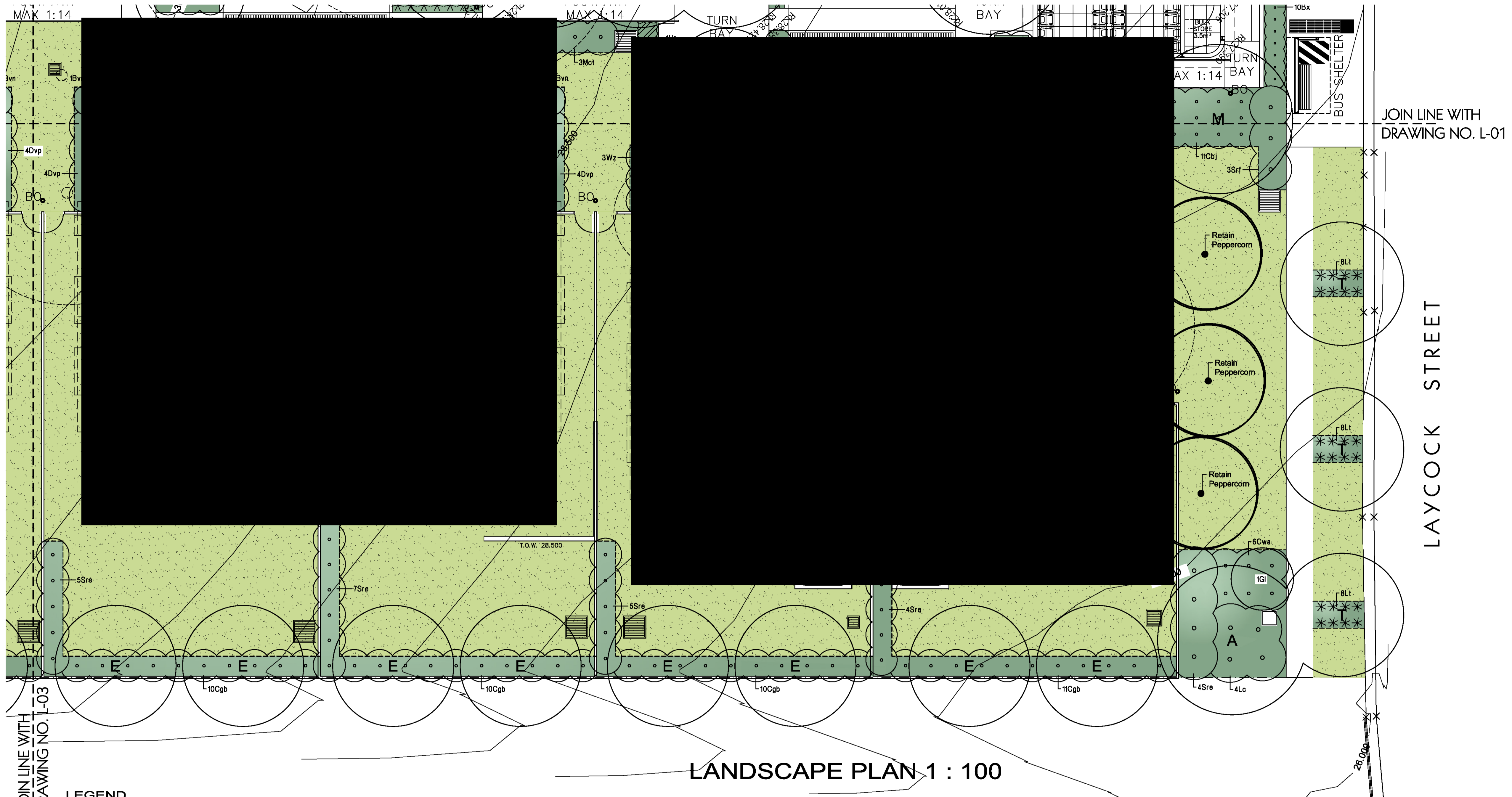

LANDSCAPE PLAN 1 : 100

JOIN LINE WITH DRAWING NO. L-03

JOIN LINE WITH DRAWING NO. L-01

LAYCOCK STREET

LEGEND

- turf**  
Excavate / grade all areas to be turfed to 120mm below required finished levels. Do not excavate within 1500mm of the trunk of any existing tree to be retained. Ensure that all surface water runoff is directed towards inlet pits, kerbs etc., and away from buildings. Ensure that no ponding will occur. Rip the subgrade to 150mm. Install 100mm depth of imported topsoil. Just prior to spreading the turf, spread "Shirley's No. 17 lawn fertilizer" over the topsoil at the recommended rate. Lay "Kikuyu" turf rolls closely butted. Fill and small gaps with topsoil. Water thoroughly.
- brick garden edging**  
Lay a single course of paving bricks in a mortar haunch (200mm wide and 100mm deep). The edges are to be laid in even curves and straight lines as shown on the plan. Where tight curves are shown use half bricks to show a more even curve. The top of the edges to finish flush with the adjacent turf and mulch levels.
- existing trees to be removed**
- existing trees to be retained**
- mulch only area**  
75mm depth selected mulch to base of existing trees
- planting areas**  
Ensure that the mass planting areas have been excavated to 300mm below finished levels. Rip to a further depth of 150mm. Supply and install 300mm soil mix. Soil mix to comprise of one part approved compost to three parts topsoil. Topsoil shall be either imported topsoil or stockpiled site topsoil (if suitable i.e. No clay). Install 75mm depth of selected mulch.
- maintenance:**  
All landscape works are to be maintained for a period of three months from the date of practical completion. This includes all watering, weeding, spraying and re-mulching necessary to achieve vigorous growth. Any defects which arise during this period are to be rectified immediately. Any plants or areas of turf which fail during this period are to be replaced at no additional cost.
- fencing:**  
For all fencing types and materials refer to the Architects plans.

PLANT SCHEDULE

Code	Latin Name (Common Name - Mature Height)	Qty	Size	Stake
<b>■ Shrubs</b>				
Bvn	Baeckea virgata 'nans' (Dwarf baeckea - 0.5m)	27	5 litre	-
Bx	Buxus microphylla 'Japonica' (Box - 1m)	19	5 litre	-
CbJ	Callistemon 'Better John' (Dwarf Bottlebrush - 1m)	104	5 litre	-
CjJ	Callistemon 'Little John' (Dwarf Bottlebrush - 1m)	6	5 litre	-
Cgb	Callistemon salignus 'Great balls of fire' (Bottlebrush - 1.5m)	85	5 litre	-
Cwa	Callistemon 'White Anzac' (White Bottlebrush - 1.5m)	124	5 litre	-
Dvp	Dodonaea viscosa 'Purpurea' (Purple Hop Bush - 2m)	36	5 litre	-
Ep	Eriostemon profusus (Free flowering wax flower - 1.3m)	4	5 litre	-
Gpc	Grevillea 'Peaches & Cream' (Grevillea - 1.5m)	2	5 litre	-
Gi	Grevillea 'Moonlight' (Moonlight grevillea - 3m)	5	5 litre	-
Hyl	Hymenosporum flavum 'Lushious' (Native frangipani - 0.5m)	43	5 litre	-
Lc	Leptospermum 'Cardwell' (Dwarf Tea Tree - 2m)	22	5 litre	-
Mth	Metrosideros thomasi (NZ Christmas Bush - 5m)	8	5 litre	-
Mct	Melaleuca 'Claret Tops' (Paperbark - 1.2m)	3	5 litre	-
Mt	Melaleuca thymifolia (Rock Myrtle - 1m)	97	5 litre	-
Sre	Syzygium australe 'Resilience' (Lilly Pilly - 3m)	48	5 litre	-
Srf	Syzygium leucomanthi 'Royal flame' (Lilly Pilly - 2m)	6	5 litre	-
Wz	Westringia 'Zena' (Westringia - 1m)	10	5 litre	-

PLANT SCHEDULE

Code	Latin Name (Common Name - Mature Height)	Qty	Size	Stake
<b>■ Trees</b>				
A	Angophora floribunda (Rough Barked apple - 12m)	1	35 litre	yes
B	Elaeocarpus eumundi (Smooth leaved Quandong - 8m)	8	35 litre	yes
E	Elaeocarpus reticulatus (Blue berry ash - 8m)	24	35 litre	yes
F	Eucalyptus ficifolia 'Summer Red' (Red flowering gum - 5m)	4	35 litre	yes
G	Melaleuca bracteata revolution green (Bracelet myrtle - 3m)	6	35 litre	yes
M	Melaleuca linarifolia (Narrow leaved Paperbark - 6m)	1	35 litre	yes
T	Tristania laurina 'Luscious' (Water Gum - 10m)	6	35 litre	yes
W	Waterhusia floribunda (Waterhusia - 10m)	1	35 litre	yes
<b>■ Groundcovers</b>				
DjJ	Dianella 'Little jess' (Dianella - 0.4m)	153	150mm pot	
Hs	Hibbertia scandens (Guinea flower - climber)	40	150mm pot	
Lf	Lomandra longifolia (Lomandra - 1m)	12	150mm pot	
Lrj	Liriope 'Evergreen Giant' (Giant liriope - 0.5m)	51	150mm pot	
Lt	Lomandra longifolia 'Tanika' (Fine leaf dwarf lomandra - 0.6m)	107	150mm pot	
Pan	Pandorea 'Jasminoides - Dark pink' (Bower vine - climber)	12	150mm pot	

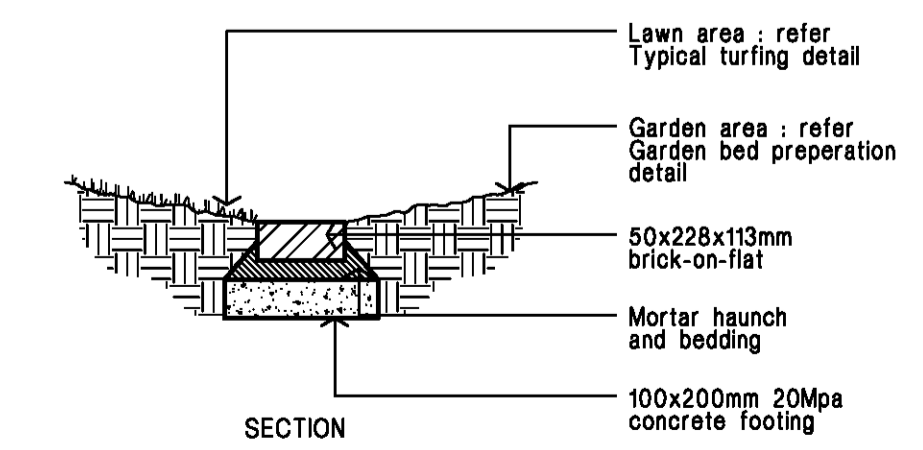
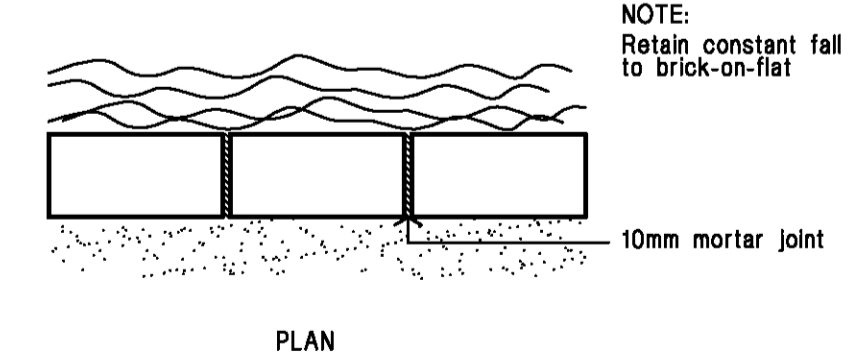

Brick garden edge Detail.

NOTES:  
FOR ADDITIONAL DETAILS  
REFER TO DRAWING NO. L-03

05.07.21 Rev DA to include new bin store and bus shelter B  
09.12.20 DA Issue A  
DATE AMENDMENT ISSUE

**RFA** RAY FUGGLE ASSOCIATES  
landscape architects  
18 NEW FARM ROAD  
WEST PENNANT HILLS  
NSW 2125  
email: RAY@fuggle.net.au  
0412 294 712  
abn 18 003 773 639

Project:  
**PROPOSED SENIORS HOUSING DEVELOPMENT**  
No. 103-109 Laycock Street,  
**CRANEBROOK**

Client:  
**Mr F. CATANEA**

Drawing Title:  
**LANDSCAPE PLAN**

Issue:	rev. DA	date:	05/07/21	Issue no:	B
file name:		scale:	1:100 @ A1	drawing No:	
drawn:	HK	project No:	4527c		
checked:	RF				L-02/4



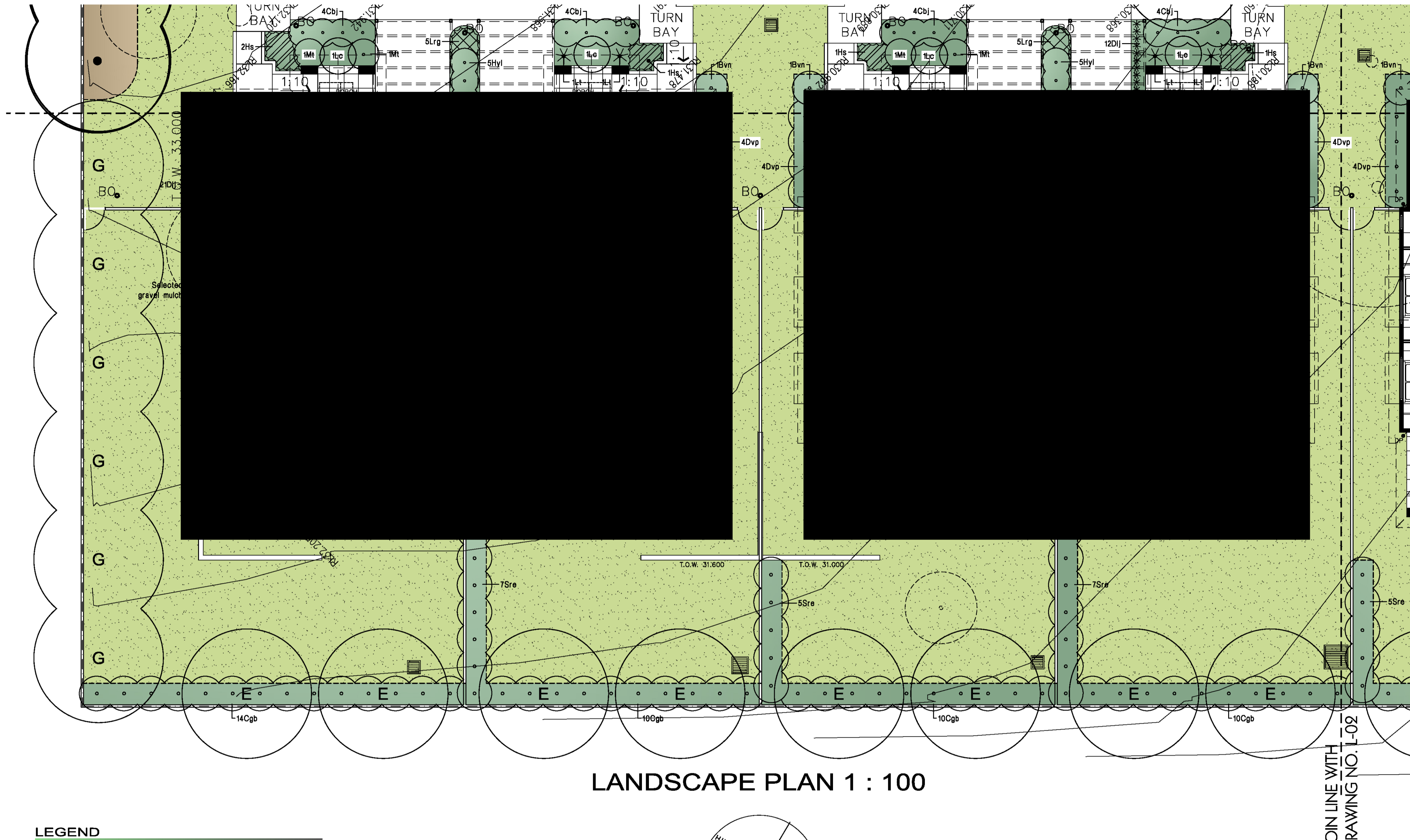



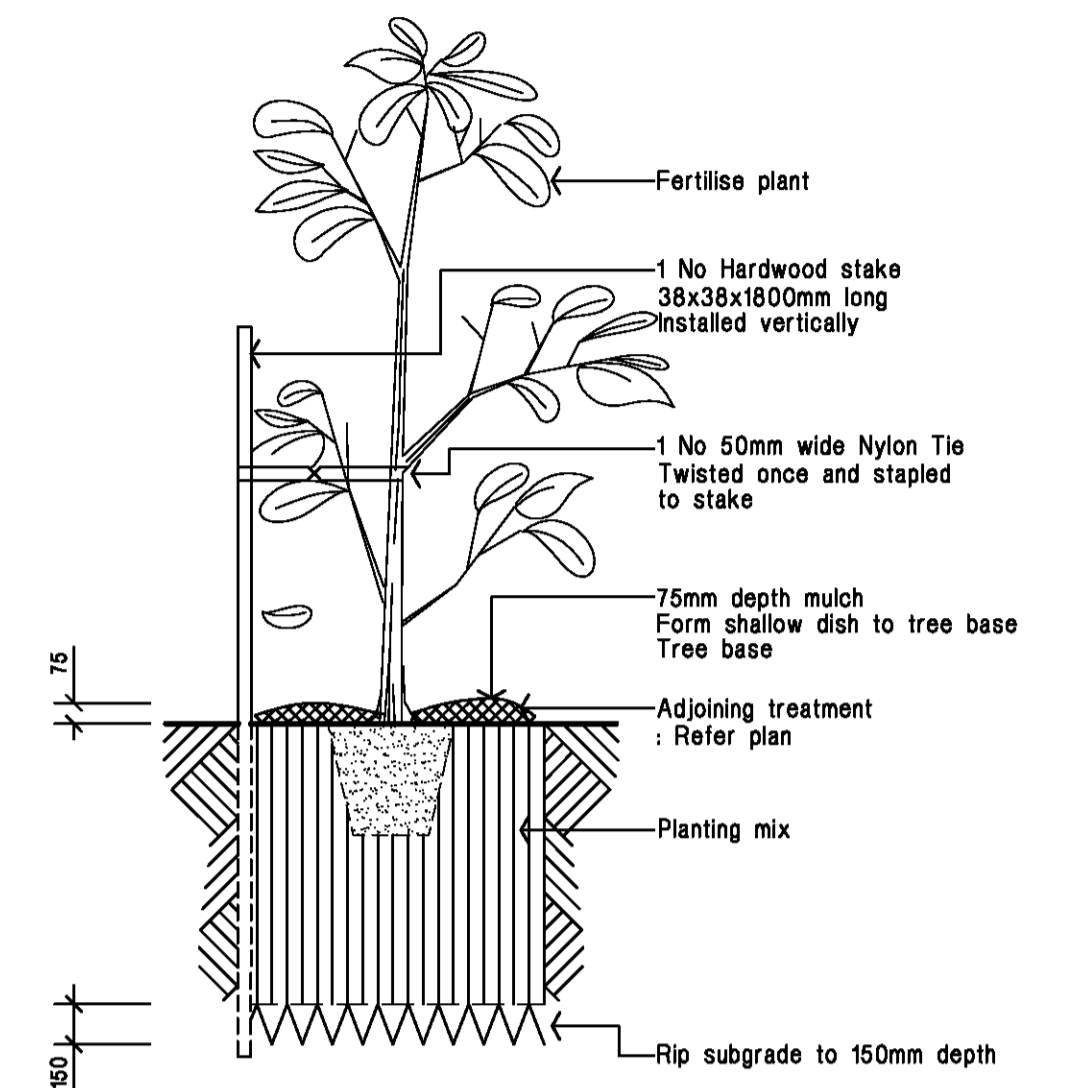

LANDSCAPE PLAN 1 : 100

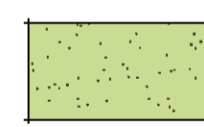
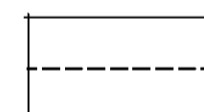

15 - 35 litre Tree planting  
Detail. Not.To.Scale.

NOTES:  
FOR PLANT SCHEDULE AND  
DETAILS REFER TO DRAWING  
NO. L-02

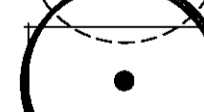
LEGEND

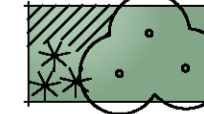
-  turf  
Excavate / grade all areas to be turfed to 120mm below required finished levels. Do not excavate within 1500mm of the trunk of any existing tree to be retained. Ensure that all surface water runoff is directed towards inlet pits, kerbs etc. and away from buildings. Ensure that no ponding will occur. Rip the subgrade to 150mm. Install 100mm depth of imported topsoil. Just prior to spreading the turf, spread "Shirley's No. 17 lawn fertilizer" over the topsoil at the recommended rate. Lay "Kikuyu" turf rolls closely butted. Fill and small gaps with topsoil. Water thoroughly.
-  brick garden edging  
Lay a single course of paving bricks in a mortar haunch (200mm wide and 100mm deep). The edges are to be laid in even curves and straight lines as shown on the plan. Where tight curves are shown use half bricks to show a more even curve. The top of the edges to finish flush with the adjacent turf and mulch levels.
-  existing trees to be removed  
...
-  existing trees to be retained  
...
-  mulch only area  
75mm depth selected mulch to base of existing trees
-  planting areas  
Ensure that the mass planting areas have been excavated to 300mm below finished levels. Rip to a further depth of 150mm. Supply and install 300mm soil mix. Soil mix to comprise of one part approved compost to three parts topsoil. Topsoil shall be either imported topsoil or stockpiled site topsoil (if suitable is: No clay). Install 75mm depth of selected mulch.
- maintenance:**  
All landscape works are to be maintained for a period of three months from the date of practical completion. This includes all watering, weeding, spraying and re-mulching necessary to achieve vigorous growth. Any defects which arise during this period are to be rectified immediately. Any plants or areas of turf which fall during this period are to be replaced at no additional cost.
- fencing:**  
For all fencing types and materials refer to the Architects plans.

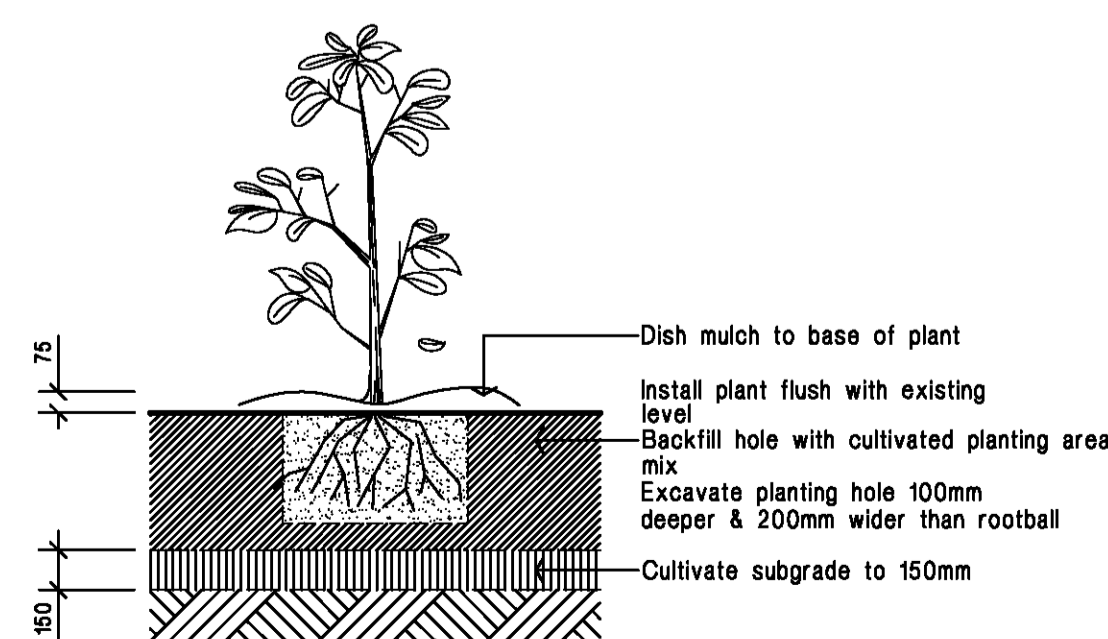
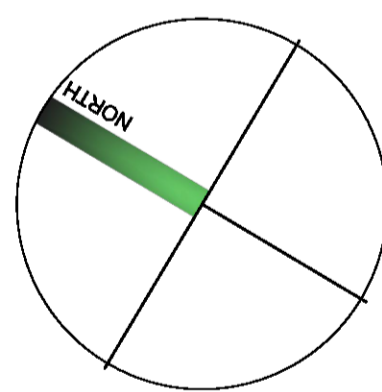

Planting in garden beds  
Detail. Not.To.Scale.

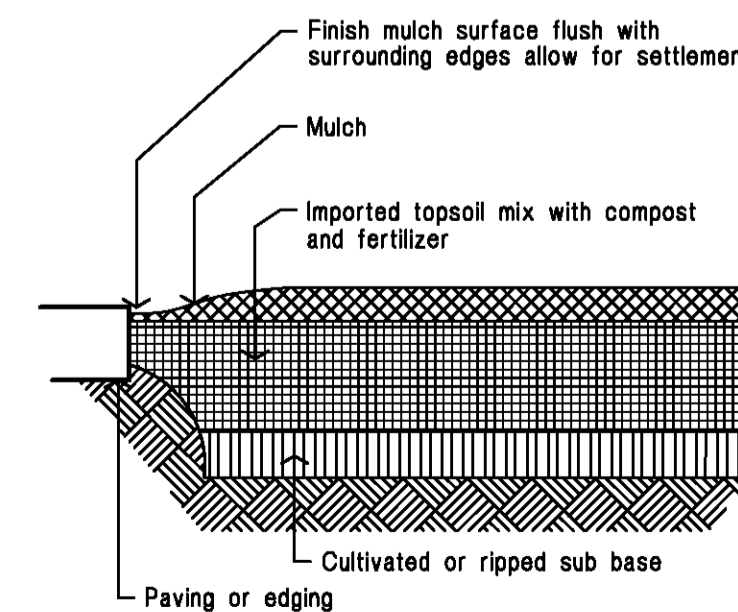

Ground preparation  
Planting area using imported topsoil  
Detail. Not.To.Scale.

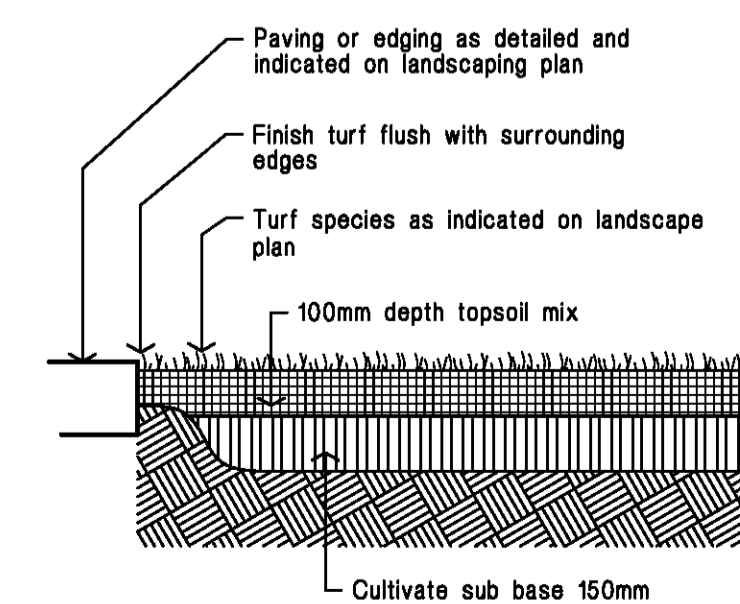

Ground preparation  
Grassed area: turf using imported topsoil  
Detail. Not.To.Scale.

05.07.21 Rev DA to include new bin store and bus shelter B  
09.12.20 DA Issue A  
DATE AMENDMENT ISSUE

**RFA** + RAY FUGGLE ASSOCIATES  
landscape architects  
18 NEW FARM ROAD  
WEST PENNANT HILLS  
NSW 2125  
email: RAY@fuggle.net.au m 0412 294 712  
a 18 003 773 639

Project:  
PROPOSED SENIORS HOUSING DEVELOPMENT

No. 103-109 Laycock Street,  
**CRANEBROOK**



Client:  
Mr F. CATANEA

Drawing Title:  
**LANDSCAPE PLAN**

Issue:	rev. DA	date:	05/07/21	Issue no:	B
file name:		scale:	1:100 @ A1	drawing No:	
drawn:	HK	project No:	4527c		
checked:	RF				L-03/4

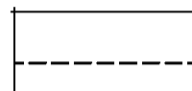
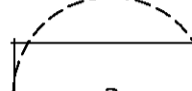
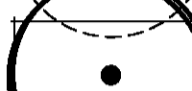

LEGEND

-  turf  
Excavate / grade all areas to be turfed to 120mm below required finished levels. Do not excavate within 1500mm of the trunk of any existing tree to be retained. Ensure that all surface water runoff is directed towards inlet pits, kerbs etc., and away from buildings. Ensure that no ponding will occur. Rip the subgrade to 150mm. Install 100mm depth of imported topsoil. Just prior to spreading the turf, spread "Shirley's No. 17 lawn fertilizer" over the topsoil at the recommended rate. Lay "Kikuyu" turf rolls closely butted. Fill and small gaps with topsoil. Water thoroughly.
-  brick garden edging  
Lay a single course of paving bricks in a mortar haunch (200mm wide and 100mm deep). The edges are to be laid in even curves and straight lines as shown on the plan. Where tight curves are shown use half bricks to show a more even curve. The top of the edges to finish flush with the adjacent turf and mulch levels.
-  existing trees to be removed  
...
-  existing trees to be retained  
...
-  mulch only area  
75mm depth selected mulch to base of existing trees
-  planting areas  
Ensure that the mass planting areas have been excavated to 300mm below finished levels. Rip to a further depth of 150mm. Supply and install 300mm soil mix. Soil mix to comprise of one part approved compost to three parts topsoil. Topsoil shall be either imported topsoil or stockpiled site topsoil (if suitable i.e. No clay). Install 75mm depth of selected mulch.
- maintenance:**  
All landscape works are to be maintained for a period of three months from the date of practical completion. This includes all watering, weeding, spraying and re-mulching necessary to achieve vigorous growth. Any defects which arise during this period are to be rectified immediately. Any plants or areas of turf which fall during this period are to be replaced at no additional cost.
- fencing:**  
For all fencing types and materials refer to the Architects plans.

NOTES:  
FOR PLANT SCHEDULE AND  
DETAILS REFER TO DRAWING  
NO. L-02

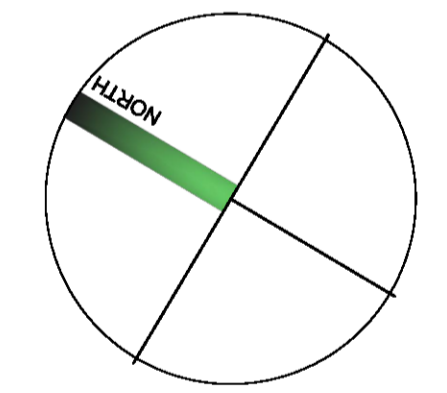

05.07.21 Rev DA to include new bin store and bus shelter B  
09.12.20 DA Issue A  
DATE AMENDMENT ISSUE

**RFA** + RAY FUGGLE ASSOCIATES  
landscape architects  
18 NEW FARM ROAD  
WEST PENNANT HILLS  
NSW 2125  
email: RAY@fuggle.net.au m 0412 294 712  
a/bn 18 003 773 639

Project:  
**PROPOSED SENIORS HOUSING DEVELOPMENT**  
No. 103-109 Laycock Street,  
**CRANEBROOK**

Client:  
**Mr F. CATANEA**

Drawing Title:  
**LANDSCAPE PLAN**

Issue:	rev. DA	date:	05/07/21	Issue no:	B
file name:		scale:	C:1	drawing No:	
drawn:	HK	scale:	1:100 @ A1	project No:	4527c
checked:	RF				L-04/4

LANDSCAPE PLAN 1 : 100