



**BLACKETT
MAGUIRE+
GOLDSMITH**

BCA ASSESSMENT REPORT

The Log Cabin
Memorial Avenue, Penrith NSW
Lots 20, 21, 22 DP 1236215

Prepared For:
FDC Construction & Fitout Pty Ltd

Project No.: 200047

Revision 0

Date: 31.03.2020





CONTENTS

| | | |
|-------------------------------------------------|-------------------------------------------------------|-----------|
| A. | INTRODUCTION | 3 |
| A.1 | BACKGROUND / PROPOSAL | 3 |
| A.2 | AIM | 3 |
| A.3 | PROJECT TEAM | 3 |
| A.4 | DOCUMENTATION | 3 |
| A.5 | REGULATORY FRAMEWORK | 3 |
| A.6 | LIMITATIONS & EXCLUSIONS | 4 |
| A.7 | TERMINOLOGY | 4 |
| B. | BUILDING CHARACTERISTICS | 6 |
| B.1 | BUILDING CLASSIFICATION | 6 |
| B.2 | FIRE SOURCE FEATURE | 6 |
| C. | BCA ASSESSMENT | 6 |
| C.1 | BCA DEEMED-TO-SATISFY COMPLIANCE ISSUES: | 6 |
| | SECTION B – STRUCTURE | 6 |
| | SECTION C – FIRE RESISTANCE | 7 |
| | SECTION D – ACCESS & EGRESS | 9 |
| | SECTION E – SERVICES AND EQUIPMENT | 16 |
| | SECTION F – HEALTH & AMENITY | 18 |
| | SECTION J – ENERGY EFFICIENCY | 21 |
| E. | CONCLUSION | 22 |
| APPENDIX 1 – SPEC. C1.1 FRL REQUIREMENTS | | 23 |
| | TABLE 4 TYPE B CONSTRUCTION: FRL OF BUILDING ELEMENTS | 23 |

| REPORT STATUS | | | | |
|---------------|----------|---------------------------------------------------------|--------|----------|
| DATE | REVISION | STATUS | AUTHOR | REVIEWED |
| 31.03.2020 | 0 | Preliminary Assessment – For Client & Consultant Review | DG | TH |

Prepared by:

Dean Goldsmith
Director

Blackett Maguire + Goldsmith



A. INTRODUCTION

A.1 BACKGROUND / PROPOSAL

Blackett Maguire + Goldsmith Pty Ltd (BM+G) have been commissioned by FDC Construction & Fitout, to undertake a preliminary review of the proposed development, against the deemed-to-satisfy (DTS) provisions of the Building Code of Australia 2019 (BCA) pursuant to the provisions of clause 145 of the *Environmental Planning & Assessment Regulation 2000* and clause 18 of the *Building Professionals Regulation 2007*.

It is noted that the new pub project includes a Ground Floor Open Plan Bar, Restaurant and BOH areas, and a First-Floor Function and Bar area on Lot 21 of DP 1236215. There are also provisions for a proposed new on-grade carpark on Lot 22 of DP 1236215.



Source: Team2 Architects Roof Plan DA202 (Rev.2)

A.2 AIM

The aim of this report is to:

- + Undertake an assessment of the proposed pub facility against the Deemed-to-Satisfy (DtS) Provisions of the BCA 2019.
- + Identify any BCA compliance issues that require resolution/attention for the proposed development at the CC Application stage.

A.3 PROJECT TEAM

The following BM+G Team Members have contributed to this Report:

- + Dean Goldsmith (Director)
- + Tony Heaslip (Peer Review Building Surveyor)
- + Sabine Blakeman (Junior Building Surveyor)

A.4 DOCUMENTATION

The following documentation has been reviewed, referenced and/or relied upon in the preparation of this report:

- + BCA 2019
- + Guide to the BCA 2019.
- + Architectural plans prepared by Team2 Architects, as listed below:

| Drawing No. | Rev. | Date | Drawing No. | Rev. | Date |
|-------------|------|------------|-------------|------|------------|
| DA010 | 8 | 18.03.2020 | DA201 | 2 | 16.03.2020 |
| DA050 | 5 | 16.03.2020 | DA202 | 2 | 16.03.2020 |
| DA100 | 7 | 18.03.2020 | DA301 | 3 | 16.03.2020 |
| DA101 | 7 | 18.03.2020 | | | |

A.5 REGULATORY FRAMEWORK

Pursuant to clause 145 of the Environmental Planning and Assessment (EPA) Regulation 2000 all new building work must comply with the current BCA however the existing features of an existing building need not comply with the BCA unless upgrade is required by other clauses of the legislation.



A.6 LIMITATIONS & EXCLUSIONS

The limitations and exclusions of this report are as follows:

- + The following assessment is based upon a review of the architectural documentation.
- + No assessment has been undertaken with respect to the Disability Discrimination Act (DDA) 1992. The building owner should be satisfied that their obligations under the DDA have been addressed. In this regard however, the provisions of the DDA Access to Premises – Buildings Standards have been considered as they are generally consistent with the accessibility provisions of the BCA.
- + The Report does not address matters in relation to the following:
 - i. Local Government Act and Regulations.
 - ii. NSW Public Health Act 1991 and Regulations.
 - iii. Occupational Health and Safety (OH&S) Act and Regulations.
 - iv. Work Cover Authority requirements.
 - v. Water, drainage, gas, telecommunications and electricity supply authority requirements.
 - vi. DDA 1992.
- + BM+G Pty Ltd do not guarantee acceptance of this report by Local Council, FRNSW or other approval authorities.
- + No part of this document may be reproduced in any form or by any means without written permission from BM+G Pty Ltd. This report is based solely on client instructions, and therefore, should not be used by any third party without prior knowledge of such instructions.

A.7 TERMINOLOGY

Alternative/Performance Solution

A Building Solution which complies with the Performance Requirements other than by reason of satisfying the DtS Provisions.

Building Code of Australia (BCA)

Document published on behalf of the Australian Building Codes Board. The BCA is a uniform set of technical provisions for the design and construction of buildings and other structures throughout Australia and is adopted in New South Wales (NSW) under the provisions of the EPA Act and Regulation. Building regulatory legislation stipulates that compliance with the BCA Performance Requirements must be attained and hence this reveals BCA's performance based format.

Construction Certificate

Building Approval issued by the Certifying Authority pursuant to Part 4A of the EP&A Act 1979.

Construction Type

The construction type is a measure of a buildings ability to resist a fire. The minimum type of fire-resisting construction of a building must be that specified in Table C1.1 and Specification C1.1, except as allowed for—

- (i) certain Class 2, 3 or 9c buildings in C1.5; and
- (ii) a Class 4 part of a building located on the top storey in C1.3(b); and
- (iii) open spectator stands and indoor sports stadiums in C1.7.

Note: Type A construction is the most fire-resistant and Type C the least fire-resistant of the types of construction.

Climatic Zone

Is an area defined in BCA Figure A1.1 and in Table A1.1 for specific locations, having energy efficiency provisions based on a range of similar climatic characteristics.

Deemed to Satisfy Provisions (DtS)

Provisions which are deemed to satisfy the Performance Requirements.

Effective Height

The vertical distance between the floor of the lowest storey included in the calculation of rise in storeys and the floor of the topmost storey (excluding the topmost storey if it contains only heating, ventilating, lift or other equipment, water tanks or similar service units)



Fire Resistance Level (FRL)

The grading periods in minutes for the following criteria-

- (a) structural adequacy; and
- (b) integrity; and
- (c) insulation,

and expressed in that order.

Fire Source Feature (FSF)

The far boundary of a road which adjoins the allotment; or a side or rear boundary of the allotment; or an external wall of another building on the allotment which is not a Class 10 building.

National Construction Code Series (NCC)

The NCC was introduced 01 May 2011 by the Council of Australian Governments. The BCA Volume One (Class 2 to 9 Buildings) is now referenced as the National Construction Code Series Volume One — BCA.

Occupation Certificate

Building Occupation Approval issued by the Principal Certifying Authority pursuant to Part 4A of the EPA Act 1979.

Open Space

A space on the allotment, or a roof or other part of the building suitably protected from fire, open to the sky and connected directly with a public road.

Performance Requirements of the BCA

A Building Solution will comply with the BCA if it satisfies the Performance Requirements. A Performance requirement states the level of performance that a Building Solution must meet.

Compliance with the Performance Requirements can only be achieved by-

- (a) complying with the DtS Provisions; or
- (b) formulating an Alternative Solution which-
 - (i) complies with the Performance Requirements; or
 - (ii) is shown to be at least equivalent to the DtS Provisions; or
- (c) a combination of (a) and (b).

Sole Occupancy Unit (SOU)

A room or other part of a building for occupation by one or joint owner, lessee, tenant, or other occupier to the exclusion of any other owner, lessee, tenant, or other occupier and includes a dwelling.



B. BUILDING CHARACTERISTICS

B.1 BUILDING CLASSIFICATION

The following table presents a summary of relevant building classification items of the proposed pub development:

| | |
|------------------------------|---------------------------------------------------------------------------|
| BCA Class: | Class 6 (Restaurants/Coffee Area) & Class 9b (Function Rooms/Bars) |
| Rise in Storeys: | Two (2) |
| Effective Height: | Effective Height <12m |
| Type of Construction: | Type B Construction |
| Climate Zone: | Zone 6 |
| Maximum Floor Area: | Approximately 4,979m ² - Architect to confirm exact Floor Area |
| Maximum Volume: | Architect to confirm volume |

B.2 FIRE SOURCE FEATURE

The distances from the nearest Fire Source Features are:

| BOUNDARY | DISTANCE TO FIRE SOURCE FEATURE |
|--------------------------|-----------------------------------|
| Western Boundary | >6m (the side allotment boundary) |
| Southern Boundary | 3m (the side allotment boundary) |
| Northern Boundary | >6m (the side allotment boundary) |
| Eastern Boundary | >6m (the side allotment boundary) |

C. BCA ASSESSMENT

C.1 BCA DEEMED-TO-SATISFY COMPLIANCE ISSUES:

The following comments have been made in relation to the relevant BCA provisions relating to the compliance issues associated with the proposed pub building.

SECTION B – STRUCTURE

1. Part B1 – Structural Provisions

Structural engineering details prepared by an appropriately qualified structural engineer to be provided to demonstrate compliance with Part B1. This will include the following Australian Standards (where relevant):

- + AS 1170.0 – 2002 General Principles
- + AS 1170.1 – 2002, including certification for balustrades (dead and live loads)
- + AS 1170.2 – 2011, Wind loads
- + AS 1170.4 – 2007, Earthquake loads
- + AS 3700 – 2018, Masonry Structures
- + AS 3600 – 2018, Concrete Structures
- + AS 4100 – 1998, Steel Structures and/or
- + AS 4600 – 2018, Cold formed steel Structures.
- + AS 2159 – 2009, Piling Design & Installation
- + AS 1720 – 2010, Design of Timber Structure
- + AS/NZS 1664.1 & 2 – 1997, Aluminium Structures
- + AS 2047 – 2014, Windows and External Glazed Doors in buildings.
- + AS 1288 – 2006, Glass in buildings.
- + AS 3660.1 – 2014, Termite control (or confirmation no primary building elements are timber).



Comments: Structural design and certification will be required at CC application stage.

SECTION C – FIRE RESISTANCE

FIRE RESISTANCE AND STABILITY

2. C1.1 – Type of Construction Required

The minimum type of fire-resisting construction of a building must be that specified in Table C1.1 and Specification C1.1 except as allowed for in this clause.

Comments: Type B construction applies to the building as it has a rise in storeys of two (2) in a Class 6 & Class 9b Building, taking on the most fire-resisting construction type per C1.3 see below.

3. Clause C1.3 – Buildings of Multiple Classification

In a building of multiple classifications, the type of construction required for the building is the most fire-resisting type resulting from the application of Table C1.1 on the basis that the classification applying to the top storey applies to all storeys.

Comments: The higher Type of Construction is required for the Class 9b building with a rise in storeys of two (2), Type B construction to apply or otherwise to be fire separated.

4. Clause C1.9 – Non-Combustible Building Elements

In a building of Type A or Type B Construction a number of building elements are required to be non-combustible including external walls & common walls (including elements incorporated in them including the façade coverings, framing and insulation), lift pit flooring and floor framing, services risers, load-bearing internal walls and fire walls.

Note: C1.9(e) provides a list of materials that may be deemed as non-combustible without the need for verification testing per AS 1530.1.

Comments: The external walls (including all elements incorporated in the walls) of the building are required to be of non-combustible construction in accordance with C1.9 (a) & (b) – see further comments below under C1.14 also. Details are required at the Construction Certificate Application stage.

5. Clause C1.10 – Fire Hazard Properties

The fire hazard properties of the proposed wall, floor & ceiling linings, materials (such as insulation & sarking) and other assemblies in a Class 2 to 9 building must comply with Specification C1.10 and the additional requirements of the NSW Provisions of Spec. C1.10.

Comments: Architect to note. Details demonstrating compliance to be provided at the Occupation Certificate stage.

6. Clause C1.14 – Ancillary Elements

An ancillary combustible element must not be fixed, installed or attached to the internal or external parts of a non-combustible wall unless it is one of the concession items listed in items (b) – (m).

Comments: The architectural elements in the proposed development facades will require review to confirm that the proposed internal & external attachments to the external walls achieve compliance with the non-combustibility requirements of this clause – see comments under C1.9 also.

COMPARTMENTATION AND SEPARATION

7. Clause C2.2 – General Floor Area and Volume Limitations

Sets out the parameters for the area and volume of Class 5, 6, 7, 8 & 9 buildings as required by sub-clauses (a), (b) & (c).

Note: Table C2.2 maximum size of Fire Compartments or Atriums.

Comments: The maximum compartment size permitted to the Class 6 part is 3,500m² with a volume of 21,000m³, and in Class 9b part is 5,500m² with a volume of 33,000m³. Based on a percentage split calculation between the Class 6 & Class 9b areas (As outlined in the BCA Guide) the maximum permitted fire compartment size for the building is estimated (Ground Floor + First Floor Combined) = 63% Class 6; 37% Class 9b) – Maximum Compartment Size per C2.2 = 4,240m². & 25,440m³. Compliance is readily achievable – Architect to confirm exact floor area + volume.



8. Clause C2.10 – Separation of Lift Shafts

Applies to all classes of buildings and specifies the protection requirements for openings for lift shafts and lift landing doors. The requirements are set out in sub-clauses (a), (b) (c) & (d) which relate to openings in Type A, B and C construction. Also note the Deemed to Satisfy Provisions of Clause C3.10.

Comments: The lifts serving all parts of both the building are not required to be enclosed in a fire rated shaft as they only connect two (2) storeys.

9. Clause C2.12 – Separation of Equipment

Equipment as listed below must be separated from the remainder of the building with construction complying with (d), if that equipment comprises –

- (i) Lift motors and lift control panels; or
- (ii) Emergency generators used to sustain emergency equipment operating in the emergency mode; or
- (iii) Central smoke control plant; or
- (iv) Boilers; or
- (v) A battery or batteries installed in the building that have a voltage exceeding 12 volts and a storage capacity exceeding 200kWh.

Note: Separating construction must have –

- (A) an FRL as required by Specification C1.1, but not less than 120/120/120; and
- (B) any doorway protected with a self-closing fire door having an FRL of not less than -/120/30.

Comments: Architect to note. Details of the enclosures containing the above equipment (where applicable) are to be noted on the floor plan and enclosed in 120/120/120 FRL construction.

10. Clause C2.13 – Electricity Supply System

(a) An electricity substation, main switchboard which sustains emergency equipment operating in the emergency mode, located within a building must –

- (i) Be separated from any other part of the building by construction having an FRL of not less than 120/120/120; and
- (ii) Having any doorway in that construction protected with a self-closing fire door having an FRL of not less than -/120/30

(b) A main switchboard located within the building which sustains emergency equipment operating in the emergency mode must—

- (i) Be separated from any other part of the building by construction having an FRL of not less than -/120/30.
- (ii) Have any doorway in that construction protected with a self-closing fire door having an FRL of not less than -/120/30.

(c) Electrical conductors located within a building that supply

Note: Where emergency equipment is required in a building, all switchboards in the electrical installation, which sustain the electricity supply to the emergency equipment switchgear is separated from the non-emergency equipment switchgear by metal partitions designed to minimise the spread of fault from the non-emergency equipment switchgear.

Comments: Architect to note. Details of the enclosures containing the above equipment (where applicable) are to be noted on the floor plan and enclosed in 120/120/120 FRL construction.

PROTECTION OF OPENINGS

11. Clause C3.2 – Protection of Openings in External Walls

Openings in external walls that are required to have an FRL, which are to be exposed to a fire-source feature, are required to be protected in accordance with C3.2(a) & C3.2(b).

Openings in an external wall that is required to have an FRL must –

- (a) If the distance between the opening and the fire-source feature to which it is exposed is less than –
 - (i) 3 m from a side or rear boundary of the allotment; or
 - (ii) 6 m from the far boundary of a road, river, lake or the like adjoining the allotment, if not located in a storey at or near ground level; or
 - (iii) 6 m from another building on the allotment that is not a Class 10, be protected in accordance with C3.4 and if wall-wetting sprinklers are used, they are located externally; and



- (b) If the required to be protected under (a), not occupy more than 1/3 of the area of the external wall of the storey in which it is located unless they are in a Class 9b building used as an open spectator stand.

Comments: There are no openings in the external walls that require protection per clause C3.2.

12. Clause C3.15 – Openings for Services Installations

All opening for services installations in building elements required to be fire-resisting with respect to integrity and insulation must be protected in accordance with the provisions of Spec. C3.15.

Comments: Compliance is to be demonstrated with the Construction Certificate documentation.

SPECIFICATIONS

13. Specification C1.1 – Fire Resisting Construction

The new building works are required to comply with the requirements detailed under Table 5 of Specification C1.1 for Type C Construction. In this regard the proposed building elements are required to comply.

Comments: Compliance is readily achievable for the requirements of Type B construction. In this regard the following building elements are required to achieve a FRL:

- + Load-bearing elements in the external walls within 18m of the Southern Allotment Boundary
- + External Columns within 18m of the Southern Allotment Boundary.
- + Internal Columns on the Ground Floor Level supporting the Level 1 Floor.

Note: A Performance Solution may be required for the external columns on the terraces in the South-west corner of the building.

14. Specification C1.10 – Fire Hazard Properties.

This Specification sets out requirements in relation to the fire hazard properties of linings, materials and assemblies in Class 2 to 9 buildings as set out in the Tables.

Comments: Design team to note. Materials test reports and specifications will need to be provided to allow for further assessment to ensure compliance with the above addressed in Clause C1.9.

SECTION D – ACCESS & EGRESS

PROVISION FOR ESCAPE

15. Clause D1.2 -- Number of Exits Required

This clause requires the provision of sufficient exits to enable safe egress in case of an emergency. D1.2 provides that all buildings must have at least one exit from each storey and sets out circumstances in which more than one exit may be required (particularly in relation to Class 9 buildings).

Note 1: Not less than 2 exits must be provided from each storey if the building has an effective height of more than 25m.

Note 2: Not less than 2 exits must be provided from any storey that involves a vertical rise within the building of more than 1.5m unless the floor area of the storey is not more than 50m² and the distance of travel from any point on the floor to a single exit is not more than 20m.

Comments: The proposed number of exits in the building complies with the above requirements (2 Exits provided from each storey).

16. Clause D1.4 – Exit Travel Distances

This clause specifies the permitted travel distances allowable from Class 2 to Class 9 buildings. Sub-clauses (a) to (f) specify the maximum distances to be taken into account for the various uses in each Class of building.

Comments: Exit travel distances do not comply within the building. The following areas have been identified and will need to be addressed by the Fire Safety Engineer as an Performance Solution addressing Performance Requirement DP4 & EP2.2.

- + Ground Floor – 42.2m

17. Clause D1.5 – Distances Between Alternative Exits

Exits required as alternative exits must be –

- (a) not less than 9m apart; and



- (b) not more than – 60m apart.
- (c) Located so that the alternative paths of travel do not converge such that they become less than 6m apart.

Comments: The distances between alternative exits in the proposed building are considered to be non-compliant with the requirements of Clause D1.5. The following areas have been identified and will need to be addressed by the Fire Safety Engineer as a Performance Solution addressing Performance Requirement DP4 & EP2.2.

- + Ground Floor – 65m

18. Clause D1.6 – Dimensions of Exits

This clause details the minimum dimensions such as height and width of paths of travel from Class 2 to 9 buildings. It also specifies the minimum dimensions of doorways from the various compartments and the width of exit doors from buildings depending on the uses and functions carried out within them.

Comments: Exit corridors and stairs and other paths of travel are to be a minimum 1m in width and 2m in height clear of any obstructions. The unobstructed height of any doorway may be reduced to not less than 1980mm and the width may be reduced by 250mm from the required exit dimensions listed below.

The population numbers have been determined in accordance with D1.13 (see below) and as a result the following minimum exit widths area required from each floor as follows:

- + Ground Floor – 5.5m (Complies – 6.5m proposed)
- + First Floor – 5.5m (Non-compliant – 5.0m proposed - Performance Solution from the Fire Engineer will be required).

Note: The width of the corridors and the discharge door on Ground Level must maintain the minimum clear width of the First-Floor exit stairs directly to open space – via the Coffee Shop and Loading Dock exits (Minimum 2.5m wide corridors and 2.25m wide doorways). This is applicable to the exit doors/ passageway in the South-east corner from the Café and to the exit doors/ BOH passageway from the northern side of the loading dock.

19. Clause D1.9 – Travel by Non-fire-isolated Stairways or Ramps

Sub-clauses (a) to (f) set out the prescribed travel distances to be provided in required exits of Class 2 to 9 buildings and Class 4 parts of buildings. The sub-clauses set out the maximum distances to be taken into account for the various uses in each Class of building.

A non-fire isolated stairway or ramp serving as a required exit must provide a continuous means of travel by its own flights and landings from every storey served to the level at which egress to a road or open space is available. This clause sets out the prescribed travel distances to be provided in required exits of Class 2 to 9 buildings and Class 4 parts of buildings, and also maximum total distances to be taken into account for the various uses in each Class of building.

Comments: Compliance with the provisions of D1.9 is readily achievable.

20. Clause D1.10 – Discharge From Exits

Requires that an exit must not be blocked at the point of discharge. Barriers such as bollards must be installed to prevent vehicles from blocking the discharge from exits.

This clause also provides the methods of construction, location and separation, at exit discharge points for all building Classes.

Comments: The pathways from exit discharges points around the site to the public road are to be detailed to comply with the requirements of this clause at Construction Certificate Application stage. Noting where a change in level is present, compliant stairways or ramps not steeper than 1:8 is required.

21. Clause D1.13 – Number of Persons Accommodated

Clause D1.13 and Table D1.13 are used to calculate the anticipated number of people in particular types of buildings so that minimum exit widths and the required number of sanitary and other facilities can be calculated. This clause and table are not to be used for non-BCA purposes.

Comments: The population numbers within each level have been calculated as follows based upon assumptions of each areas use and calculated per square metre:

- + Ground Floor = Population of 701 persons (Patrons and Staff).
- + First Floor = Population of 598 persons (Patrons and Staff).



22. Clause D1.17 – Access to Lift Pits

This clause provides the requirements for access to lift pits not more than 3m deep and the requirements of construction of access for lift pits that are more than 3m deep. The requirement for signage to lift pits is also set out.

Comments: Lift Contractor to note. Details are to be provided with the Construction Certificate documentation.

CONSTRUCTION OF EXITS

23. Clause D2.3 – Non-fire-isolated Stairways & Ramps

This clause requires that required non-fire-isolated stairways and ramps must be either constructed in accordance with D2.2 with non-combustible materials or the alternative options set out in D2.3 (a) to (c).

Comments: The requirements of D2.3 apply to the proposed First floor exit stairs - details are to be provided of the stair design at CC application stage.

24. Clause D2.7 – Installations in Exits & Paths of Travel

This clause restricts the installation of certain services in fire-isolated exits, non-fire-isolated exits and certain paths of travel to exits. It prescribes which services shall not be installed as well as the circumstances in which certain services may be installed in fire-isolated and non-fire-isolated exits. If installed in a path of travel to an exit, electrical distribution boards, communication cupboards and the like containing motors, etc are to be enclosed with non-combustible construction, and doors are to be provided with smoke seals to the perimeter.

Comments: Architect to note. Details are to be provided with the Construction Certificate documentation.

25. Clause D2.8 – Enclosure of Space under Stairs and Ramps

The space below a required fire-isolated stairway or ramp in a fire-isolated shaft must not be enclosed to form a cupboard or other enclosed space. If the required stairway or ramp is non-fire-isolated, (including an external stairway) any cupboard underneath must have an FRL of 60/60/60, with a self-closing -60/30 door.

Comments: Applies to Cupboards/enclosures under exit stairs on Ground Floor. Details are to be included on the CC Plans.

26. Clause D2.13 – Goings & Risers

This clause sets out the detailed requirements for the construction and geometry of the goings and risers in required stairways. These details are set out in sub-clauses (a) to (c) and Table D2.13 Riser and Going Dimensions.

Comments: All stairs are to be designed with compliant dimensions per Table D2.13 below, have solid risers, and are to have contrasting nosings, slip resistant surfaces throughout in accordance with clause 11 of AS1428.1-2009. Refer to the slip resistance for stairs below under Clause D2.14 also. Details to be confirmed with the Occupation Certificate documentation.

| Riser and Going Dimensions (mm) | | | |
|---------------------------------|-----------|-----------|-------------------|
| | Riser (R) | Going (G) | Quantity (2R + G) |
| Maximum | 190 | 355 | 700 |
| Minimum | 115 | 250 | 550 |

27. Clause D2.14 – Landings

The dimensions and gradients of landings in stairways are set out in this clause; the configuration will depend on the proposed use of a building. Sub-clause (b) details the layout for a Class 9a building to allow for the movement of a stretcher.

Comments: Details to be confirmed with the Occupation Certificate documentation.

| Application | Surface conditions | |
|--------------------------------------------------|--------------------|-----------|
| | Dry | Wet |
| Ramp steeper than 1:14 | P4 or R11 | P5 or R12 |
| Ramp steeper than 1:20 but not steeper than 1:14 | P3 or R10 | P4 or R11 |
| Tread or landing surface | P3 or R10 | P4 or R11 |



28. Clause D2.15 – Thresholds

The threshold of a doorway must not incorporate a step or ramp at any point closer to the doorway than the width of the door leaf unless –

- (i) the doorway opens to a road or open space, external stair landing or external balcony; and
- (ii) the door sill is not more than 190mm above the finished surface of the ground, balcony, or the like, to which the doorway opens.

Comments: Architect to note, details demonstrating compliance will be required to be included in the CC plans.

29. Clause D2.16 – Balustrades or Other Barriers

This clause details where balustrades are required to be provided and sets out in specific detail the construction requirements in sub-clauses (a) to (i) and Tables D2.16(a), D2.16(b) & D2.16(c). Typically, the following will apply to this class of building:

- + Balustrades are required where the fall to the level below is more than 1m in height. The minimum height of a balustrade is 1m above the floor of the landing, walkway or the like; and 865mm above the floor of a stairway or a ramp.
- + For a fall of more than 4m to the surface level below, a window sill must be a minimum of 865mm in height above the height of the floor surface.
- + Where the floor is more than 4m above the surface beneath the balustrade any horizontal or near horizontal members between 150mm and 760mm above the floor must not could facilitate climbing.
- + Balustrades must be constructed so as to not permit a sphere of 125mm diameter to pass through. The exception to this is within fire isolated exits within the building, or within a class 7 or 8 building, where the rails can be positioned a maximum of 460mm apart, so long as a bottom rail is located so a sphere of 150mm cannot pass through the opening between the nosing of the stair treads and the rail or between the floor of the landing, balcony or the like.

Comments: Details of the proposed balustrades are to be provided with the application for the Construction Certificate for assessment detailing the above.

30. Clause D2.17 – Handrails

This Clause sets out the requirements regarding the location, spacing and extent of handrails required to be installed in buildings.

Comments: Details of the proposed handrails are to be provided for assessment with the application for the Construction Certificate. See also parts of this report relating to Part D3 for the additional requirements for handrails. (See Part D3 below)

31. Clause D2.20 – Swinging Doors

A swinging door in a required exit or forming part of a required exit must be installed to the requirements of sub-clauses (a), (b) & (c). This clause only applies to swinging doors in doorways serving a required exit or forming part of a required exit. It does not apply to other doorways – see notes in the Guide to the BCA.

Comments: Compliance with the requirements of this Clause is readily achievable.

32. Clause D2.21 – Operation of Latch

A door in a required exit or forming part of a required exit and in a path of travel to a required exit must be readily openable without a key from the side that faces a person seeking egress, by a single downward action or pushing action on a single device which is located between 900mm & 1.1m from the floor. This clause prohibits the use of devices such as deadlocks and knobs where knobs must be operated in a twisting motion in accordance with sub-clauses (a) & (b). D2.21 also sets out exceptions in relation to buildings where special security arrangements are required in relation to the uses carried out.

Comments: Architect to note. Sliding Doors to be used as exit path to Main Entry Door, Games Room Door and South-west Terraces on Ground Floor and First Floor are required to be compliant with the provisions of this clause and details demonstrating compliance will be required to be included in the CC plans.



ACCESS FOR PEOPLE WITH A DISABILITY

33. Clause D3.1 - General Building Access Requirements.

The extent of access required depends on the classification of the building. Buildings and parts of buildings must be accessible as set out in Table D3.1 unless exempted by Clause D3.4.

Comments: Compliant accessibility is required throughout all parts the proposed buildings (except those areas exempted under D3.4 - see notes below) or that are not required to be accessible in the Class 3 SOU and some parts of the Class 7a portions of the building. In this regard, we note the following:

- + Compliant Access is required to the accessible parking spaces and the adjoining lifts as well and throughout the staff accessible areas on all levels.
- + Compliant Access is required throughout all parts (excluding those exempted under D3.4 below) of all floors.

Note: Compliance with the above is readily achievable – refer to Access Consultant's Report.

34. Clause D3.2 –Access to Buildings

This part requires accessways to be provided to accessible buildings from the main points of pedestrian entry at the allotment boundary and any accessible car parking space or accessible associated buildings connected by a pedestrian link.

Comments: AS 1428.1-2009 compliant access is required to be provided to the main entry lobby doors from the adjoining external drop off area and accessible carparks in the adjoining allotment – refer to Access Consultant's Report.

35. Clause D3.3 – Parts of the Building to be Accessible

This part specifies the requirements for accessways within buildings and where the requirements of AS 1428.1-2009 are applicable.

Comments: The following is a summary of some of the key matters which need to be considered to ensure compliance with the requirements of this part and AS 1428.1-2009 have been achieved:

The following is a summary of some of the key matters which need to be considered from Clause D3.3 and AS 1428.1-2009:

- + Access for persons with disabilities must be provided, at a minimum, to and within all areas normally used by the occupants including staff.

Accessways and Doors

- + The minimum width of an accessible doorway must have a clear opening width of not less than 850mm in accordance with AS1428.1.
- + All doorways on a continuous path of travel shall have a minimum luminance contrast of 30% provided between: door leaf and door jamb; or door leaf and adjacent wall; or architrave and wall; or door leaf and architrave; or door jamb and adjacent wall. The minimum width of the area of luminance contrast shall be 50mm.
- + Internal surfaces are to comply with Section 7 of AS1428.1-2009.
- + Internal tiles or internal vinyls are to comply with AS 4586.
- + All finished floor surfaces are to be trip free, the following details demonstrate the tolerance level for floor finishes:

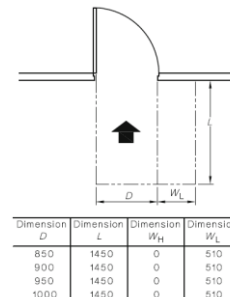
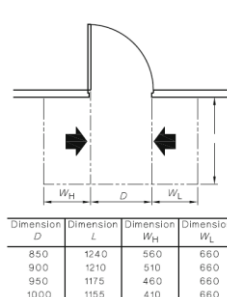
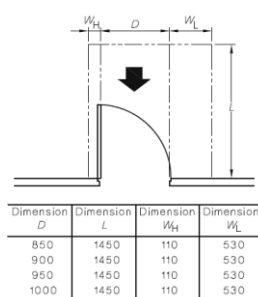
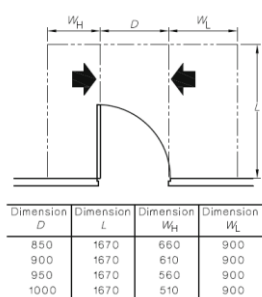



- + Any proposed carpets within the building are to have a pile height or pile thickness not exceeding 11mm and the carpet backing thickness shall not exceed 4mm (total thickness shall not exceed 15mm)
- + Circulation space to the new doorways that are required to be accessible are to comply with Section 13 of AS1428.1-2009, examples of which are as follows:

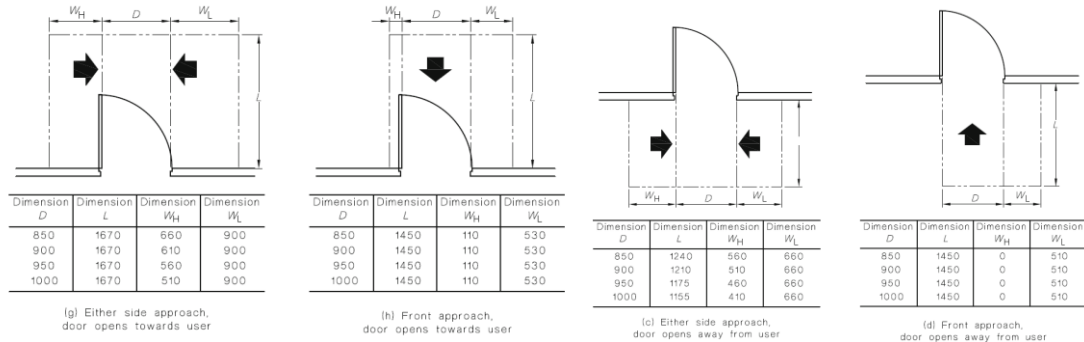

Circulation space requirements at doorways

- + Turning Spaces and Passing Spaces in Common Corridors are required to be provided on each level in accordance with Clauses 6.4 & 6.5 of AS 1428.1-2009.
- + All frameless glass panels or fully glazed doors on an accessway are to be clearly marking in accordance with AS 1428.1. In this instance, all frameless glass panel or fully glazed doors, including glazing capable of being mistaken for a doorway or opening, shall be marked with a full width solid non transparent contrast line not less than 75mm wide is required to be located between 900mm and 1000mm above floor level.

Stairways

- + Every common area stairway must be constructed in accordance with Clause 11 of AS1428.1, except if they are within a fire isolated exit or serve the areas in the building that a D3.4 Exemption has been applied to. As such, the stairways must be designed to comply with the accessibility requirements of Clause 11 of AS1428.1-2009 and details will need to be confirmed on the plans for CC.

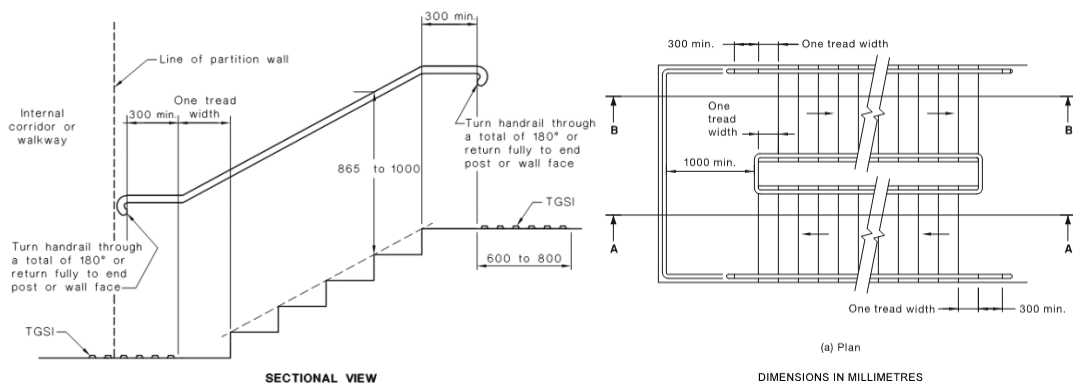

- + Stairs shall have opaque risers (i.e. Solid)
- + Stair nosing's shall comply with the following diagram, which achieve a colour contrast luminance of 30% to the background (tread):

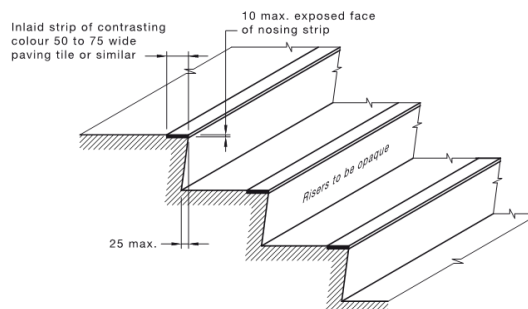



- + Stairways are to be served by Tactile Ground Surface Indicators in accordance with AS1428.4.1, except if they are within a fire isolated exit.

Handrails

- + Handrails shall be installed along stairways as follows:
 - o Shall be continuous through the flight and where practicable, around landings and have no obstruction on or above up to a height of 600mm,
 - o Installed along both sides of the stairway (giving consideration also to 1m unobstructed width),
 - o Shall have a compliant hand clearance in accordance with Figure 29 of AS 1428.1-2009.

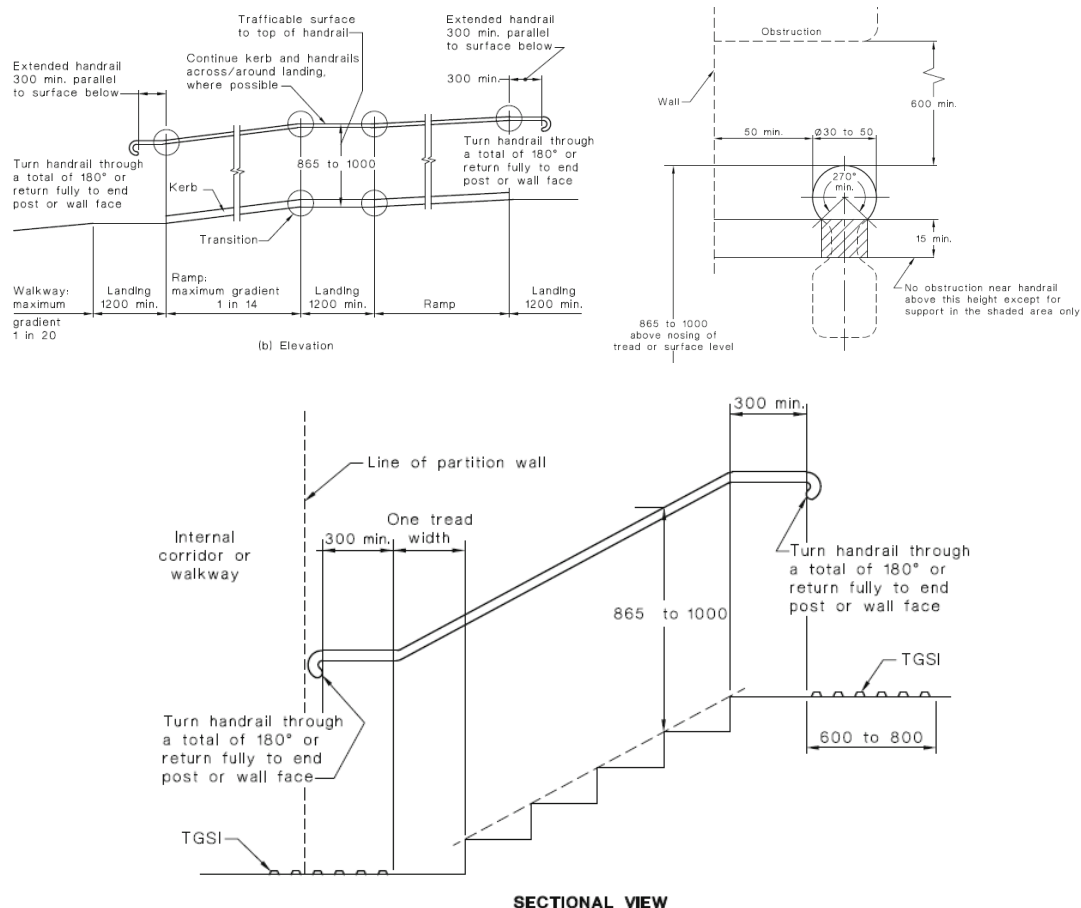

36. Clause D3.4 – Exemptions

This part provides exemptions to the Deemed-to-Satisfy provisions for access by people with a disability. This part provides details on buildings or parts of buildings not required to be accessible under the BCA where providing access would be inappropriate because of the nature of the area or the tasks undertaken.

Comments: It is recommended that advice be obtained from an accredited Access Consultant at the CC Application stage, however, It is noted that any concessions to be applied under D3.4 will need to be the subject of an application by FDC at the CC Application to the Certifier. The most likely areas where D3.4 may be applied are the plantrooms, Loading Dock area and the back-of-house kitchen areas on Ground Floor and First Floor.

37. Clause D3.5 – Accessible Carparking

This part provides details of the number of accessible carparking spaces required in a carpark depending on the classification of the building.

Comments: Accessible compliant carparking is required to be provided at the following rates:

- + Class 6 & 9b – 1 accessible compliant space per 50 parking spaces provided on site – To be confirmed.



Note: Design details to be provided at Construction Certificate Application stage.

38. Clause D3.6 – Signage

This section provides requirements for signage in buildings required to be accessible By Part D3.

Comments: Signage, including Braille & tactile signage where appropriate, is required to comply with BCA clause D3.6 and Section 8 of AS 1428.1-2009 for sanitary facilities, ambulant facilities and disabled car parking spaces. In addition, the signage to the accessible toilet facilities is to also identify the facility for left and right-handed use.

39. Clause D3.7 – Hearing Augmentation

This part provides requirements for provision of hearing augmentation in accessible buildings, i.e. to be provided where an in-built amplification system (other than one used for emergencies), is installed:

- + In a room in a Class 9b building;
- + In an auditorium, conference room, meeting room, or room for judiciary purposes.

At any ticket office, teller's booth, reception area or the like where the public is screened from the service provider.

Comments: A Hearing Augmentation System will be required to be installed where an inbuilt amplification system is installed in the Class 9b Bar & Function areas.

40. Clause D3.8 – Tactile Indicators

This clause provides for the installation of tactile indicators in buildings required to be accessible and must be provided to warn people who are blind or have a vision impairment that they are approaching a stairway, escalator, passenger conveyor, ramp, overhead obstruction or an accessway meeting a vehicular way, except for areas exempted by D3.4.

Comments: Stairways and ramps serving the building along with any overhead obstructions less than 2.1m in height, will need to be provided with Tactile Ground Surface Indicators in accordance with AS1428.4.

41. Clause D3.12 – Glazing on an Accessway

This part requires the provision of a contrasting strip, chair rail, handrail or transom across all frameless or fully glazed doorways and surrounding glazing capable of being mistaken for an opening.

Comments: Design details to note requirements for full height glazing

SECTION E – SERVICES AND EQUIPMENT

FIRE FIGHTING EQUIPEMENT

42. Clause E1.3 - Fire hydrants

E1.3(a) – A fire hydrant system must be provided to serve a building having a total floor area greater than 500m² and where a fire brigade is available to attend a building fire.

E1.3(b) – Requires that the fire hydrant system must be installed in accordance with the provisions of AS2419.1 and also details where internal hydrants must be located.

Comments: The Building is required to be served by a hydrant system that is compliant with AS 2419.1-2005. The location of the proposed booster assembly is required to be on the allotment and in view of the main entry of the building and will need to be addressed as an Performance Solution from the Fire Engineer if this is not achievable.

43. Clause E1.4 – Fire hose reels

A fire hose reel system must be provided to serve a building where one or more internal fire hydrants are installed or in a building with a floor area greater than 500m².

This clause requires that the fire hose reel system must be installed in accordance with AS 2441 and sets out the detail for location and uses of fire hose reels.

Comments: The Building is required to be served by a system of fire hose reels. A plan shall be provided with the CC application together with a design certificate to AS2441-2005 that details the coverage provided by the fire hose reels.



44. Clause E1.5 – Sprinklers

A sprinkler system must be installed in a building or part of a building when required by Table E1.5 and comply with Specification E1.5. Table E1.5 sets out which types of building occupancies and Classes which are required to have sprinkler systems installed in them.

Specification E1.5 sets out requirements for the design and installation of sprinkler systems.

Comments: The building is not required to be sprinkler protected.

45. Clause E1.6 – Portable fire extinguishers

Portable fire extinguishers must be provided as listed in Table E1.6 and must be selected, located and distributed in accordance with Sections 1, 2, 3 and 4 of AS 2444.

Comments: Fire extinguishers will be required to be installed in the proposed building in accordance with Table E1.6 and AS 2444-2001.

SMOKE HAZARD MANAGEMENT

46. Clause E2.2 – General Requirements

Class 2 to 9 buildings must comply with the provisions of this Clause to remove smoke during a fire, to control the operation of air handling systems and to prevent the spread of smoke between compartments.

Buildings must comply with the provisions of **Table E2.2a**, as applicable to Class 2 to 9 buildings. It deals with the design and construction of air handling systems that are part of a smoke hazard management system and air handling system that are not part of a smoke hazard management system.

The details relating to the installation and operation of the systems are set out in **Specifications E2.2a, E2.2b and E2.2c**.

Comments: A smoke detection and alarm system is required to be provided throughout the building in accordance with Table E2.2b and Spec. E2.2a, as the Class 9b Fire Compartment exceeds 2,000m² per Spec. E2.2a clauses.

It is also noted that the mechanical ventilation systems in the Pub/Bar facility are required to be designed in accordance with a system of automatic shutdown on activation of the smoke detection system.

PART E3 LIFT INSTALLATIONS

47. Clause E3.3 – Warning Against use of Lifts in Fire

Warning signs required be provided must be displayed where they can be readily seen and must comply with the details and dimensions of **Figure 3.3**.

Comments: Applies to the proposed lift in the building - Lift Contractor to note. Compliance is readily achievable. Details to be confirmed with the documentation provided with the CC application.

48. Clause E3.5 – Landings

E3.5(a) The provisions of clause 12.2 – “Access” of AS 1735.2 do not apply.

E3.5(b) The provisions of Clause A3.2 – “Access to landings” of Appendix A of AS 1735.1 do not apply.

E3.5(c) Access and egress to and from lift well landings must comply with the Deemed-to-Satisfy Provisions of Part D, including AS 1428.1-2009.

Comments: Design certification from the lift supplier shall be provided with the documentation submitted with the Construction Certificate application.

49. Clause E3.6 – Passenger Lifts

In an accessible building, every passenger lift must be one of the types identified in **Table E3.6a**, have accessible features in accordance with **Table E3.6b** and not rely on a constant pressure device for its operation if the lift car is fully enclosed.

Comments: The passenger lifts are required to be designed to comply with AS1735.2 and AS1735.12. and design certification from the lift supplier shall be provided with the documentation submitted with the Construction Certificate application.



EMERGENCY LIGHTING, EXIT SIGNS AND WARNING SYSTEMS

50. Clause E4.2 – Emergency Lighting Requirements

This clause details when emergency lighting must be installed in Class 2 to 9 buildings. The requirements for buildings and parts of buildings are detailed in sub-clauses (a) to (i) and each sub-clause must be considered as more than one may apply to any single building

Comments: Emergency Lighting is required throughout the building in accordance with E4.2, E4.4 and AS/NZS 2293.1-2005. Design details shall be provided with the documentation provided with the Occupation Certificate application.

51. Clause E4.4 – Design & Operation of Emergency Lighting

Every required emergency lighting system must comply with AS2293.1.

Comments: Electrical Consultant to note.

52. Clause E4.5 – Exit Signs

An exit sign must be clearly visible to persons approaching the exit and must be installed on, above or adjacent to each door providing egress from a building. Sub-clauses (a) to (d) set out the situations where exit signs are required to be installed.

Comments: Electrical Consultant to note, details demonstrating compliance will be required to be included in the CC plans.

53. Clause E4.6 – Direction Signs

If an exit is not readily apparent to persons occupying or visiting the building then exit signs must be installed in appropriate positions in corridors, hallways, lobbies, and the like, indicating the direction to a required exit.

Comments: Design details shall be provided with the documentation provided with the Occupation Certificate application.

54. Clause E4.8 – Design & Operation of Exit Signs

Every required exit sign must comply with AS/NZS 2293.1 and be clearly visible at all times when the building is occupied by any person having the legal right of entry into the building.

Comments: Electrical Consultant to note, details demonstrating compliance will be required to be included in the CC plans.

SECTION F – HEALTH & AMENITY

DAMP AND WEATHERPROOFING.

55. Clause F1.1 – Stormwater drainage

Stormwater drainage must comply with AS/NZ 3500.3-2018.

Comments: Details of stormwater disposal, from a suitably qualified consultant are required to be submitted with documentation for the CC.

56. Clause F1.5 – Roof Coverings

This clause details the materials and appropriate standards, with which roofs must be covered with. The roofing requirements are set out in sub-clauses (a), (b) (c), (d), (e) & (f) which set out the types of materials that may be used and the adopted Australian Standards that apply to their quality and installation.

Comments: Note – design certification required at CC Application stage.

57. Clause F1.7 – Waterproofing of Wet Areas

This clause requires that wet areas in Class 2 to 9 buildings must be waterproofed. It prescribes the standards to which the work must be carried on the construction of rooms containing urinals and their installation.

Comments: Note – design certification required at CC Application stage.



58. Clause F1.13 – Glazed Assemblies

Glazed assemblies in an external wall must comply with AS2047 requirements for resistance to water penetration for windows, sliding doors with a frame, adjustable louvres, shop fronts and windows with one-piece framing

Comments: Note – design certification required at CC Application stage.

SANITARY AND OTHER FACILITIES

59. Clause F2.2 – Calculation of Numbers of Occupants & Facilities

This clause sets out the requirements for the calculation of the number of occupants and the number of sanitary facilities required to be installed in Class 2 to 9 buildings. The parameters for the calculation are set out in sub-clauses (a) to (d).

Comments: See comments under Clause D1.13.

60. Clause F2.3 – Facilities in Class 3 to 9 Buildings

This clause provides the requirements for sanitary facilities to be installed in Class 3, 5, 6, 7, 8 and 9 buildings in accordance with **Table F2.3**. The requirements and variations are set out in sub-clauses (a)-(h).

Comments: The required sanitary facilities for the Class 6 & 9b portions of the proposed building have been calculated as follows, based upon the population numbers detailed in D1.13 above:

Patrons (Population: 1268 – 634M/F Split) -

+ Male: 4 WC's, 9 Urinals, 5 Wash Basins; and Female: 10 WC's, 5 Wash Basins

Staff (Population: 33 – 17M/F Split) -

+ Male: 1 WC, 1 Urinals, 1 Wash Basins; and Female: 2 WC, 1 Wash Basins

Note: Sanitary requirements were calculated from Table F2.3 as Class 6 – Restaurants, cafes, bars for Patrons and Class 3, 5, 6 and 9 (other than schools) for Staff.

Note 1: Compliance with the above requirements is readily achievable, based on the current design.

Note 2: As the other portions of the building are ancillary to the Pub/Bar Function facility additional sanitary facilities are not considered to be required, however confirmation of staff numbers for assessment will be required at CC Application Stage to confirm the adequacy of Staff Toilet facilities.

61. Clause F2.4 – Accessible Sanitary Facilities

Accessible unisex sanitary compartments must be provided, in accordance with **Table F2.4(a)** and unisex showers must be provided in accordance with **Table F2.4(b)**, in buildings or parts that are required to be accessible. The details for the provision of disabled facilities and the standard, AS 1428.1, are set out in sub-clauses (a) to (i).

Comments: Accessible compliant toilets are required at each bank of toilets where one or more toilets is provided. In addition, to an Accessible unisex sanitary compartment at that bank of toilets, an ambulant sanitary facility is required to be provided for use by male and female persons per AS 1428.1-2009. Note: Compliance with the above requirement is readily achievable.

62. Clause F2.5 – Construction of Sanitary Compartments

Other than in an early childhood centre, sanitary compartments must have doors and partitions that separate adjacent compartments and extend –

- + from floor level to the ceiling in the case of a unisex facility; or
- + a height of not less than 1.5m above the floor if primary school children are the principal users; or
- + 1.8m above the floor in all other cases.

The door to a fully enclosed sanitary compartment must open outwards; or slide; or be readily removable from the outside of the sanitary compartment, unless there is a clear space of at least 1.2m, measured in accordance with Figure F2.5 between the closet pan within the sanitary compartment and the doorway.

Comments: Architect to note.



ROOM HEIGHTS

63. Clause F3.1 – Height of Rooms and other spaces

The ceiling heights in Class 2 to 9 buildings must not be less than required in sub-clauses (a) to (f) of this clause.

The ceiling minimum heights for a Class 5, 6, 7 or building are as follows:

- + 2,4m;
- + Corridor, passageway or the like – 2.1m;
- + A bathroom, shower room, sanitary compartment, other than an accessible adult change facility, airlock, tea preparation room, pantry, store room, garage, car parking area, or the like – 2.1m;
- + A commercial kitchen – 2.4m; and
- + A required accessible adult change facility – 2.4m.

Comments: Architect to ensure compliance. Ceiling heights to be reviewed at the Construction Certificate stage with the detailed section drawings.

LIGHT AND VENTILATION

64. Clause F4.4 – Artificial Lighting

Artificial lighting is required where it is necessary to minimise the hazard to occupants during an emergency evacuation. Sub-clauses (a), (b) & (c) sets out the places where artificial lighting is always required in all classes of buildings and the standard to which it must be installed.

Comments: Design certification to be submitted at CC Application Stage for the building.

65. Clause F4.5 – Ventilation of Rooms

A habitable room, office, shop, factory, workroom, sanitary compartment, bathroom, shower room, laundry and any other room occupied by a person for any purpose must have natural ventilation complying with F4.6 or a mechanical or air-conditioning system complying with AS1668.2 and AS/NZS 3666.1.

Note: NSW F4.5(b) a mechanical ventilation or air-conditioning system complying with AS 1668.2 – the reference to AS/NZS 2666.1 is deleted from the BCA in NSW as the need to comply with this standard is regulated under the relevant section of the Public Health Act 1991.

Comments: Design certification from the Mechanical Consultant to be submitted at CC Application Stage for the building.

66. Clause F4.8 – Restriction on Position of Water Closets & Urinals

A room containing a water closet pan or urinal must not open directly into a kitchen or pantry, public dining room or restaurant, a dormitory in a Class 3 building, a room used for public assembly (which is not an early childhood centre, primary school or open spectator stand) or a workplace normally occupied by more than 1 person.

Comments: Compliance readily achievable.

67. Clause F4.9 – Airlocks

If a room containing a closet pan or urinal is prohibited under F4.8 from opening directly into another room then the provisions of sub-clauses (a) & (b) apply relating to the requirements of airlocks and mechanical ventilation standards

Comments: Compliance readily achievable.

68. Clause F4.12 – Kitchen Local Exhaust Ventilation

A commercial kitchen must be provided with a kitchen exhaust hood complying with AS/NZS 1668.1 and AS 1668.2 in accordance with the provisions of sub-clauses (a) and (b).

Comments: Compliance is readily achievable for the proposed Commercial Kitchens within the building.



SECTION J – ENERGY EFFICIENCY

69. Part J1 – Building Fabric

The provision of insulation of the building envelope will be required in the proposed Building, in accordance with **Clauses J1.0 to J1.6**, and the **Tables therein**, including Thermal Construction General, Roof and Ceiling Construction, Rooflights, Walls, and Floors. Design details and/or certification of design will be required to be provided in this regard.

Comments: This section applies to any air-conditioned spaces proposed within the proposed building. Design details and/or certification of building envelope design will be required to be submitted with the application for a Construction Certificate.

70. Part J2 – Glazing

Glazing within the external building envelope will be required to be assessed/designed to achieve compliance with **Clauses J2.0 to J2.5**, including the **Tables therein**, having regard to the maximum aggregate air-conditioning energy attributable to each façade of the proposed building. A calculation demonstrating that the proposed design of the building complies with the requirements of **Part J2** is required to be provided in this regard.

*Comments: This section applies to any air-conditioned spaces proposed within the proposed building. A calculation demonstrating that the proposed design of the glazing in each building complies with the requirements of **Part J2** is required to be submitted with the application for a Construction Certificate.*

71. Part J3 – Building Sealing

The proposed building envelope will be required to be sealed to prevent air infiltration in accordance with the requirements of **Clauses J3.0 to J3.6**. Details or certification that the proposed building design complies with the requirements of **Part J3** is required to be provided.

*Comments: This section applies to any air-conditioned spaces proposed within the proposed building. Details or certification that the proposed design complies with the requirements of **Part J3** will need to be submitted with the application for a Construction Certificate.*

72. Part J5 – Air-Conditioning & Ventilation Systems

Details and/or design certification which confirm that any proposed air-conditioning system or unit within the proposed building achieves compliance with the relevant requirements of **Part J5** will be required to be provided from the mechanical engineer.

Comments: Details or certification demonstrating compliance will need to be submitted with the application for a Construction Certificate for the building.

73. Part J6 – Artificial Light & Power

Details and/or design certification which confirm that all artificial lighting, power control, and boiling/chilled water units within the proposed building achieves compliance with the relevant requirements of **Part J6** will be required to be provided from the electrical engineer.

Comments: Details or certification demonstrating compliance will need to be submitted with the application for a Construction Certificate for the building.

74. Part J7 – Hot Water Supply, & Swimming Pool & Spa Pool Plant

Details and/or design certification which confirm that any proposed hot water supply system within the proposed building achieves compliance with the relevant requirements of **Part J7** (Section 8 of AS 3500.4) will be required to be provided from the hydraulic engineer.

Comments: Details or certification demonstrating compliance will need to be submitted with the application for a Construction Certificate for the building.

75. Part J8 – Facilities for Energy Monitoring

Provision for monitoring of energy consumption must be provided to a building where the floor area exceeds 500m², and must be capable of recording the consumption of gas and electricity. In addition, where the floor area of the building exceeds 2,500m² the energy monitoring facilities must be capable of individually recording air-conditioning, lighting, appliance power, central hot water supply, lifts/escalators, and other ancillary plant.



Comments: Details or certification demonstrating compliance will need to be submitted with the application for a Construction Certificate.

E. CONCLUSION

This report contains an assessment of the referenced architectural documentation for the proposed Pub/Bar Function venue building located in Memorial Avenue, Penrith against the Deemed-to-Satisfy Provisions of the BCA 2019. Arising from the review, it is considered that the proposed development can readily achieve compliance with the relevant provisions of the BCA. Where compliance matters are proposed to comply with the performance requirements (rather than DTS Provisions), the development of a Performance Solution Report will be required prior to the issue of the Construction Certificate.

The following essential fire safety measures will be required for the building;

| Essential Fire and Other Safety Measures | Standard of Performance |
|-------------------------------------------------|--------------------------------------------------------------------------------------------|
| Access Panels, Doors & Hoppers | BCA Clause C3.13 & AS 1530.4 - 2014 |
| Alarm Signaling Equipment | AS1670.3 – 2018 |
| Automatic Smoke Detection & Alarm System | BCA Spec. E2.2a & AS 1670.1 - 2018 |
| Emergency Lighting | BCA Clause E4.4 & AS 2293.1 - 2005 |
| Exit Signs | BCA Clauses E4.5, E4.6 & E4.8 and AS 2293.1 – 2005 |
| Fire Doors | BCA Clause C2.12, C2.13, C3.2, C3.4, C3.5, C3.6 & C3.7, C3.8, C3.11 and AS 1905.1 – 2005 |
| Fire Hose Reels | BCA Clause E1.4 & AS 2441 – 2005 |
| Fire Hydrant Systems | Clause E1.3 & AS 2419.1 - 2005 |
| Fire Seals | BCA Clause C3.15 & AS 1530.4 – 2014 & AS 4072.1 – 2005 |
| Lightweight Construction | BCA Clause C1.8 & AS 1530.3 – 1999 |
| Mechanical Air Handling Systems | BCA Clause E2.2, AS/NZS 1668.1 - 2015 & AS 1668.2 – 2012 |
| Paths of Travel | EP & A Regulation Clause 186 |
| Portable Fire Extinguishers | BCA Clause E1.6 & AS 2444 – 2001 |
| Warning & Operational signs | Section 183 of the EP & A Regulations 2000, AS 1905.1 - 2005, BCA Clause D3.6, D2.23, E3.3 |

Note the above fire safety schedule is indicative only and could be subject to change as result of design changes.



APPENDIX 1 – SPEC. C1.1 FRL REQUIREMENTS

Table 4 TYPE B CONSTRUCTION: FRL OF BUILDING ELEMENTS

| Building element | Class of building—FRL: (in minutes) | | | |
|-------------------------------------------------------------------------------------------------------------------------------------------------------------------------------------------------------------------|---------------------------------------------------|-------------|-------------|-------------|
| | <u>Structural adequacy/ Integrity/ Insulation</u> | | | |
| | 2, 3 or 4 part | 5, 7a or 9 | 6 | 7b or 8 |
| EXTERNAL WALL (including any column and other building element incorporated therein) or other external building element, where the distance from any <u>fire-source feature</u> to which it is exposed is— | | | | |
| For <u>loadbearing</u> parts— | | | | |
| less than 1.5 m | 90/ 90/ 90 | 120/120/120 | 180/180/180 | 240/240/240 |
| 1.5 to less than 3 m | 90/ 60/ 30 | 120/ 90/ 60 | 180/120/ 90 | 240/180/120 |
| 3 to less than 9 m | 90/ 30/ 30 | 120/ 30/ 30 | 180/ 90/ 60 | 240/ 90/ 60 |
| 9 to less than 18 m | 90/ 30/– | 120/ 30/– | 180/ 60/– | 240/ 60/– |
| 18 m or more | –/–/– | –/–/– | –/–/– | –/–/– |
| For non- <u>loadbearing</u> parts— | | | | |
| less than 1.5 m | –/ 90/ 90 | –/120/120 | –/180/180 | –/240/240 |
| 1.5 to less than 3 m | –/ 60/ 30 | –/ 90/ 60 | –/120/ 90 | –/180/120 |
| 3 m or more | –/–/– | –/–/– | –/–/– | –/–/– |
| EXTERNAL COLUMN not incorporated in an <u>external wall</u> , where the distance from any <u>fire-source feature</u> to which it is exposed is— | | | | |
| less than 3 m | 90/–/– | 120/–/– | 180/–/– | 240/–/– |
| 3 m or more | –/–/– | –/–/– | –/–/– | –/–/– |
| COMMON WALLS and FIRE WALLS— | 90/ 90 / 90 | 120/120/120 | 180/180/180 | 240/240/240 |
| INTERNAL WALLS— | | | | |
| <u>Fire-resisting</u> lift and stair <u>shafts</u> — | | | | |
| <u>Loadbearing</u> | 90/ 90/ 90 | 120/120/120 | 180/120/120 | 240/120/120 |
| <u>Fire-resisting</u> stair <u>shafts</u> | | | | |
| Non- <u>loadbearing</u> | –/ 90/ 90 | –/120/120 | –/120/120 | –/120/120 |
| Bounding <u>public corridors</u> , public lobbies and the like— | | | | |
| <u>Loadbearing</u> | 60/ 60/ 60 | 120/–/– | 180/–/– | 240/–/– |
| Non- <u>loadbearing</u> | –/ 60/ 60 | –/–/– | –/–/– | –/–/– |
| Between or bounding <u>sole-occupancy units</u> — | | | | |
| <u>Loadbearing</u> | 60/ 60/ 60 | 120/–/– | 180/–/– | 240/–/– |
| Non- <u>loadbearing</u> | –/ 60/ 60 | –/–/– | –/–/– | –/–/– |
| OTHER LOADBEARING INTERNAL WALLS and COLUMNS— | | | | |
| | 60/–/– | 120/–/– | 180/–/– | 240/–/– |
| ROOFS | –/–/– | –/–/– | –/–/– | –/–/– |