



DESIGN CONFIDENCE

FDC

Access Design Assessment Report
Design Development

Jordan Springs Tavern
Lot 3989 of DP 1190132

ACCESSIBILITY | BUILDING REGULATIONS | FIRE ENGINEERING | MANAGEMENT SERVICES

Project: Jordan Springs Tavern
Document Type: Access Design Assessment Report
Our Reference: P220_052-3_JST (ACCESS) JLS

The following report register documents the development and issue of this and each subsequent report(s) undertaken by Design Confidence (Sydney) Pty Ltd.

The technical and intellectual content contained herein remain the property of Design Confidence (Sydney) Pty Ltd and have been prepared and may only be used for the development / buildings being the subject of this report.

Revision History—

OUR REFERENCE	REMARKS	ISSUE DATE
P220_052-1_JST (ACCESS) JLS	Draft report issued to client for review and comment	29 June 2020
P220_052-2_JST (ACCESS) JLS	Report issued as FINAL	10 July 2020
P220_052-3_JST (ACCESS) JLS	Report issued as FINAL v2	17 July 2020

CONTENTS

EXECUTIVE SUMMARY	4
1.0 INTRODUCTION.....	5
1.1 General	5
1.2 Purpose of Report	5
1.3 Documentation Provided for Assessment.....	5
1.4 Limitations	5
1.5 Report Exclusions.....	5
1.6 BCA Assessment – Interpretation Notes	6
2.0 BCA ACCESS DESIGN ASSESSMENT SUMMARY	7
2.1 Interpretation.....	7
2.2 Part D3 – Access for People with a Disability.....	7
2.3 Part E3.6 – Passenger Lifts.....	7
2.4 Part F2.4 – Accessible Sanitary Facilities.....	7
2.5 Part F2.9 – Accessible Adult Change Facilities.....	7
3.0 BCA DETAILED ASSESSMENT	8
3.1 General	8
3.2 Part D3 – Access for People with a Disability.....	8
3.3 Part E3.6 – Passenger Lifts.....	11
3.4 Part F2.4 – Accessible Sanitary Facilities.....	11
3.5 Part F2.9 – Accessible Adult Change Facilities.....	12
4.0 CONCLUSION.....	13
4.1 General	13
APPENDIX 1 – Documentation Provided for Assessment	14
APPENDIX 2 – Design Checklist – Prescriptive Requirements	15
APPENDIX 3 – Inclusive Design Recommendations	34
APPENDIX 4 – Drawing Mark-ups.....	35

EXECUTIVE SUMMARY

This Access Design Assessment Report has been prepared by Design Confidence at the request of FDC and relates to the proposed Jordan Springs Tavern.

The recommendations in this report are to be developed with the ongoing design development and should be confirmed prior to construction certificate stage. As the design progresses, further review of documentation shall be undertaken to ensure that compliance with the accessibility provisions of the BCA is achieved.

Based upon our assessment to date we are of the opinion that the subject development is capable of achieving compliance with the accessibility provisions of the BCA, either by complying with the prescriptive requirements or via a performance-based approach.

With respect to the assessment undertaken, the following items shall be reviewed further as the project develops—

ITEM	DESCRIPTION	RESPONSIBILITY
1	Accessible path of travel from non-accessible entry to accessible entry is greater than 50m.	Project Architect
2	Internal circulation provisions presented with shortfalls relating to door circulation spaces.	Project Architect
3	Lack of accessible path of travel from the accessible car bay to the entrance of the building.	Project Architect
4	As design progresses, further details shall be provided to ensure compliance with the requirements of the BCA / AS1428.1-2009 is achieved, such as: <ul style="list-style-type: none"> a. Ramp / walkway details; b. Wet area (sanitary facilities) details. 	Project Architect

1.0 INTRODUCTION

1.1 General

This report has been prepared at the request of FDC and relates to the proposed Jordan Springs

The proposed development is a new Tavern/Club which includes a gaming area, bars, dining, external beer garden and kids play area.

In the context of this report and the BCA the building use can be described as follows—

CLASSIFICATION	DESCRIPTION
Class 7a	Car parking
Class 9b	Assembly Building / Function Areas

STOREYS CONTAINED (INCLUDING BASEMENT LEVELS)	
One (1)	Tavern

1.2 Purpose of Report

The purpose of this report is to identify the extent to which the architectural design documentation complies with the *accessibility provisions* of the National Construction Code – Building Code of Australia Volume 1, Edition 2019 (hereinafter referred to as the BCA), as are principally contained within Parts D3, E3.6, F2.4 and F2.9 and relevant Australian Standards.

1.3 Documentation Provided for Assessment

This assessment is based upon the architectural documentation prepared by Team 2 Architects and listed within **Appendix 1**.

1.4 Limitations

This report is based upon, and limited to, the information depicted in the documentation provided for assessment and does not make any assumptions regarding design intention or the like.

This assessment does not contain comments regarding detailed design issues such as (but not limited to): luminance contrast, slip resistance, handrail design, door schedule and door hardware specification, hearing augmentation systems, location of fittings within sanitary compartments and lift specification.

1.5 Report Exclusions

It is conveyed that this report should not be construed to infer that an assessment for compliance with the following has been undertaken—

- (i) Work Health & Safety Act and Regulations; and
- (ii) Work Cover Authority requirements; and
- (iii) Structural and Services Design Documentation; and
- (iv) The Disability Discrimination Act (DDA) 1992; and

- (v) Any parts of the BCA or any standards other than those directly referenced in this report.

1.6 BCA Assessment – Interpretation Notes

To provide the reader with additional context the following information regarding assessment methodology used in this assessment is provided below—

- (i) The following rooms / areas and associated accessways have been afforded the concession under D3.4 and access for people with disabilities need not be provided to these areas—
- Plant and equipment rooms;
 - Fire control room;
 - Services meters;
 - Commercial Kitchens;
 - Store rooms;
 - Staff WC's.
- (ii) Movable furniture is the ongoing responsibility of the occupants who should maintain appropriate circulation spaces between and around furnishings;
- (iii) The internal fit out of the retail tenancy has not been included in this assessment.

2.0 BCA ACCESS DESIGN ASSESSMENT SUMMARY

2.1 Interpretation

The following tables summarise the compliance status of the architectural design in terms of each *applicable* prescriptive provision of the BCA and indicates a **capability for compliance** ('COMPLIES') with the accessibility provisions of the BCA.

A detailed analysis and commentary are provided in **Section 3.0** of this report in the instance that prescriptive non-compliance occurs ('DOES NOT COMPLY') or further 'DESIGN DETAIL' is required. Such instances should not necessarily be considered BCA deficiencies, but rather matters which need to be considered by the design team, the certifying authority and all other relevant stakeholders as design progresses.

2.2 Part D3 – Access for People with a Disability

BCA CLAUSE	COMPLIES	DOES NOT COMPLY	DESIGN DETAIL
D3.1 General building access requirements	✓		
D3.2 Access to buildings		✓	
D3.3 Parts of buildings to be accessible		✓	
D3.5 Accessible carparking			✓
D3.6 Signage			✓
D3.7 Hearing augmentation			✓
D3.8 Tactile indicators	N/A		
D3.9 Wheelchair seating spaces	N/A		
D3.10 Swimming pools	N/A		
D3.11 Ramps			✓
D3.12 Glazing on an accessway			✓

2.3 Part E3.6 – Passenger Lifts

BCA CLAUSE	COMPLIES	DOES NOT COMPLY	DESIGN DETAIL
E3.6 Passenger lifts	N/A		

2.4 Part F2.4 – Accessible Sanitary Facilities

BCA CLAUSE	COMPLIES	DOES NOT COMPLY	DESIGN DETAIL
F2.4 Accessible unisex sanitary compartments			✓
F2.4 Sanitary facilities for people with ambulant disabilities			✓

2.5 Part F2.9 – Accessible Adult Change Facilities

BCA CLAUSE	COMPLIES	DOES NOT COMPLY	DESIGN DETAIL
F2.9 Accessible adult change facilities	N/A		

3.0 BCA DETAILED ASSESSMENT

3.1 General

With reference to the BCA Access Design Assessment Summary contained in **Section 2.0** above, the following analysis and commentary is provided.

In all instances, reference is also made to **Appendix 2**, which contains design guidance and other items which shall be coordinated by the relevant stakeholders as design progresses to ensure compliance with the deemed-to-satisfy (DTS) accessibility provisions of the BCA is achieved.

Furthermore, the analysis below contains preliminary advice regarding opportunities for the implementation of a performance-based approach in lieu of complying with the prescriptive (DTS) provisions of the BCA.

3.2 Part D3 – Access for People with a Disability

3.2.1 Clause D3.1 – General building access requirements

BUILDING CLASS	ACCESSIBILITY REQUIREMENTS
Class 7a	Access is required to and within any levels containing accessible car parking spaces.
Class 9b	Access is required to be provided to and within all areas normally used by the occupants, including to wheelchair seating spaces provided in accordance with Clause D3.9. Access is not required to be provided to tiers/platforms of seating areas that do not contain wheelchair seating spaces.
All buildings	Access is not required to be provided to the areas afforded the concession under Clause D3.4 and identified in Section 1.6 above.



3.2.2 Clause D3.2 – Access to buildings

Access into the building is provided via three (3) points, via Connection Road, along the Lake/Pond boundary and via the car park.



Figure 1 – Pedestrian Entries

The following comments are provided in regards the requirements of Clause D3.2 of the BCA—

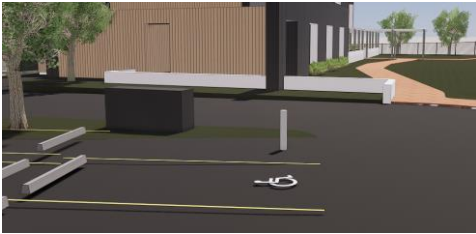
DESCRIPTION	COMMENT	SOLUTION
Gaming Entry	<p>The Gaming entrance is deemed to be non-accessible due to the step at the external step.</p> <p>The accessible entrance (Main Bar & Dining) is located ~51.3m from the accessible entry.</p> 	<p>As per Clause D3.2 of the BCA, where there is a non-accessible entry into a building, an accessible entrance must be located no greater than 50m away.</p>
Accessway	<p>The 3D model indicates a graded accessway is provided from the Lakeside Parade Road boundary to the main entry of the building.</p> 	<p>Confirmation required as to what the gradient of this accessway is.</p> <p>Ensure compliance is achieved with AS1428.1-2009 if this graded accessway is deemed to be a ramp or walkway.</p>
Access	<p>The 3D model indicates a step between the finished floor level of the car park and the path.</p> 	<p>Ensure a kerb ramp is provided between the car park and path way to allow an accessible path of travel from the accessible car bay to the entrance of the building, compliant with the BCA and AS1428.1-2009.</p>

3.2.3 Clause D3.3 – Parts of the building to be accessible

The following comments are provided in regards the requirements of Clause D3.3 of the BCA—

DESCRIPTION	COMMENT	SOLUTION
Door Circulation Space	<p>The sliding door between the Main Dining area and Gaming area on the ground floor level is provided with a latch side clearance of ~180mm.</p>	<p>Sliding doors are required to have a latch side clearance of 530mm, compliant with AS1428.1-2009.</p>

DESCRIPTION	COMMENT	SOLUTION
		Alternatively, if this door is automated via a sensor or push button, compliance is achieved as latch side clearances are not required for automated doors.

3.2.4 Clause D3.4 – Exemptions

Refer to **Section 1.6** above for areas afforded the concession under D3.4.

3.2.5 Clause D3.5 – Accessible carparking

A total of fifty-one (51) car parking spaces have been provided to the external car park. One (1) has been designated as accessible parking spaces, therefore meeting the requirements of Clause D3.5 of the BCA in regards the minimum number of accessible parking spaces required in a car parking area associated with a Class 9b building.

3.2.6 Clause D3.6 – Signage

Signage details have not yet been provided for assessment. Refer to **Appendix 2** below for further design guidance in this regard.

The following comment is provided in regards the requirements of Clause D3.6 of the BCA—

DESCRIPTION	COMMENT	SOLUTION
General	Signage details have not yet been provided for assessment.	Signage will be required in accordance with the requirements of this clause. Provide detailed drawings for review and comment.

3.2.7 Clause D3.7 – Hearing augmentation

Inbuilt amplification systems and/or hearing augmentation system details have not yet been provided for assessment. Refer to **Appendix 2** below for further design guidance in this regard.

The following comment is provided in regards the requirements of Clause D3.7 of the BCA—

DESCRIPTION	COMMENT	SOLUTION
General	Confirmation is required whether an inbuilt amplification system is provided within the building.	A hearing augmentation system will be required where an inbuilt amplification system (not being one for emergency warning only) is provided. Provide detailed drawings for review and comment.

3.2.8 Clause D3.8 – Tactile indicators

Not applicable.

3.2.9 Clause D3.9 – Wheelchair seating spaces in Class 9b assembly buildings

Not applicable.

3.2.10 Clause D3.10 – Swimming pools

Not applicable.

3.2.11 Clause D3.11 – Ramps

Refer to **Sections 3.2.3** above.

3.2.12 Clause D3.12 – Glazing on an accessway

Visual indicators have not yet been detailed within the design documentation. Refer to **Appendix 2** below for further design guidance in this regard.

The following comment is provided in regards the requirements of Clause D3.12 of the BCA—

DESCRIPTION	COMMENT	SOLUTION
General	Visual indicators have not yet been detailed within the design documentation.	Visual indicators will be required in accordance with the requirements of this clause. Provide detailed drawings for review and comment.

3.3 Part E3.6 – Passenger Lifts

Not applicable.

3.4 Part F2.4 – Accessible Sanitary Facilities

3.4.1 Accessible unisex sanitary facilities

A total of two (2) accessible sanitary compartments have been provided within the subject development.

The following comment is provided in regards the requirements of Clause F2.4 of the BCA relating to accessible sanitary facilities—

DESCRIPTION	COMMENT	SOLUTION
General	Drawings do not provide a level of details to provide comment on the accessible sanitary facilities.	As the design progresses, further details of the accessible sanitary facilities will be required to ensure

DESCRIPTION	COMMENT	SOLUTION
	Internal dimensions of each accessible sanitary facility will ensure compliance with circulation spaces required will be achieved with AS1428.1-2009.	compliance with the BCA and AS1428.1-2009 has been achieved. Refer to Appendix 2 below for further design guidance.

3.4.2 Sanitary compartment for people with ambulant disabilities

The following comments are provided in regards the requirements of Clause F2.4 of the BCA relating to sanitary facilities for people with ambulant disabilities—

DESCRIPTION	COMMENT	SOLUTION
Unisex Sanitary Facility	Although not an accessibility requirement under F2.4 of the BCA, it is assumed that the sanitary facility located on the ground floor level within the gaming area is to be used as unisex.	Male and female sanitary facilities are required to be separated. If this sanitary facility is for the use of a single sex, then compliance has been achieved.
General	Drawings do not provide a level of details to provide comment on the ambulant sanitary facilities.	At least one cubicle within each male and female sanitary facility is required to have ambulant features. As the design progresses, further details of the ambulant sanitary facilities will be required to ensure compliance with the BCA and AS1428.1-2009 has been achieved. Refer to Appendix 2 below for further design guidance.

3.5 Part F2.9 – Accessible Adult Change Facilities

Not applicable.

4.0 CONCLUSION

4.1 General

Our strategy for ensuring compliance has been refined and documented during the design process in conjunction with the continual development of the architectural documentation, as required.

Based upon our assessment to date we are of the opinion that the subject development is capable of achieving compliance with the relevant accessibility provisions of the National Construction Code – Building Code of Australia Volume 1, Edition 2019, subject to the comments provided in **Section 3.0** and the design detail contained in **Appendix 2**.

Compliance can be achieved either by meeting the deemed-to-satisfy requirements of the BCA, as are principally contained within Parts D3, E3.6, F2.4 and F2.9, or via a performance-based approach.

We trust that the above information is sufficient for the consent authority in assessing the merit of the architectural design from a planning perspective.

Report By



John La Scala
Associate | Accessibility
For Design Confidence (Sydney) Pty Ltd

Verified By



Luke Sheehy
Principal
For Design Confidence (Sydney) Pty Ltd

APPENDIX 1 – Documentation Provided for Assessment

This accessibility assessment was based upon the architectural documentation prepared by Team 2 Architects namely—

DRAWING	REV	TITLE	DATE
DA010	1	Site Plan	15.07.2020
DA100	1	Ground Floor Plan	15.07.2020

APPENDIX 2 – Design Checklist – Prescriptive Requirements

The following design guidance checklist is provided for implementation and coordination during construction in order to achieve compliance with the prescriptive requirements of the BCA, AS1428.1-2009, AS/NZS1428.4.1:2009, AS1735.12-1999 and AS/NZS2890.6:2009.

1. ACCESS TO BUILDINGS	
1.1.	Provide an accessible path of travel compliant with AS1428.1-2009 from all main pedestrian entry points at the site boundary to the principal pedestrian entrance/s of the building.
1.2.	Where a building is afforded with multiple pedestrian entries, an accessway shall be provided through and through: <ul style="list-style-type: none"> (i) The principal pedestrian entrance (PPE); and (ii) Not less than 50% of pedestrian entrances, including the PPE. <p>Where the building area is greater than 500m²:</p> <ul style="list-style-type: none"> (i) A non-accessible pedestrian entrance shall not be located more than 50m from an accessible pedestrian entrance.
1.3.	Provide an accessible path of travel compliant with AS1428.1-2009 from another building connected by a pedestrian link (not being the public footpath) within the allotment.
1.4.	Provide an accessible path of travel compliant with AS1428.1-2009 from accessible car parking spaces on the site.
1.5.	An accessible path of travel/accessway shall be in accordance with AS1428.1-2009 as applicable. <i>Note: this includes requirements relating to floor finishes, stairway, ramps, doorways etc. Refer to the relevant section below for further detail.</i>

2. PATHS OF TRAVEL	
2.1.	A continuous accessible path of travel shall not include a step, stairway, turnstile, revolving door, escalator, moving walk or the like.
2.2.	Provide 1000mm minimum clear width of path of travel compliant with AS1428.1-2009. <i>Note: the width of the path of travel shall be taken clear of any obstructions, such as handrails, kerb rails, skirting, fire hose reels, fire extinguishers or the like.</i>
2.3.	The minimum unobstructed height of a continuous path of travel shall be 2000mm or 1980mm at doorways.
2.4.	An accessway shall be provided with turning spaces in accordance with the BCA and AS1428.1-2009 where required.
2.5.	A turning space not less than 1500 x 1500mm is required to allow for a 60-90° turn on the accessway. A splay across the internal corner is permitted in accordance with Figure 4 of AS1428.1-2009.

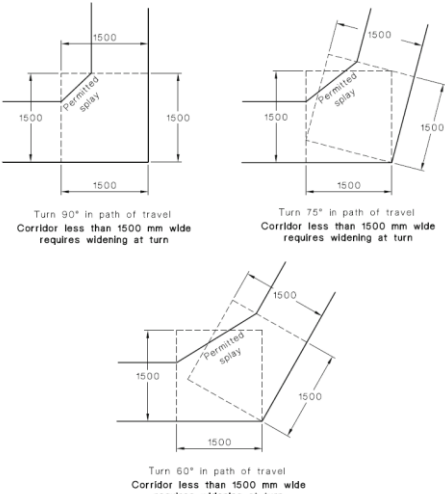

Turn 90° in path of travel
Corridor less than 1500 mm wide
requires widening at turn

Turn 75° in path of travel
Corridor less than 1500 mm wide
requires widening at turn

Turn 60° in path of travel
Corridor less than 1500 mm wide
requires widening at turn

2. PATHS OF TRAVEL

- 2.6. A turning space not less than 1540mm W x 2070mm L in accordance with Figure 5 of AS1428.1-2009 shall be provided:
- (i) to allow for a 180° turn on the accessway;
 - (ii) along pathways at maximum 20m intervals;
 - (iii) at corridor ends, within 2m of the corridor end.

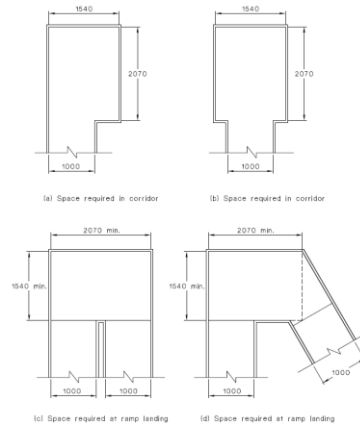

- 2.7. Where the width of the path of travel is less than 1200mm, a minimum 500x500mm splay is required to allow for a 30 to <60° turn on the accessway in accordance with Figure 4 of AS1428.1-2009.

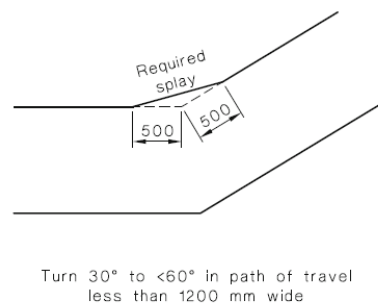

- 2.8. A passing space not less than 1800mm W x 2000mm L is required along pathways at maximum 20m intervals where a direct line of sight is not available.

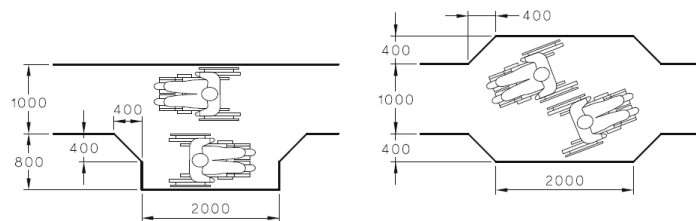

- 2.9. Floor finishes and abutment of surfaces shall be in accordance with Clause 7 of AS1428.1-2009.
Note: Reference is made to BCA Clause D2.14 in regards slip resistance requirements.

- 2.10. Where carpet or similar soft flexible flooring surface is proposed, the pile height shall be no more than 11mm with 4mm max backing surface.

- 2.11. Ensure drainage grates on accessible path of travel have openings no more than 13mm wide (or 13mm diameter).
Slotted openings shall be oriented such that the long dimension is transverse to the direction of travel.

- 2.12. Where recessed matting is proposed, it shall be in accordance with Clause 7.4.2 of AS1428.1-2009.

3. DOORS

3.1. Every door and/or gate on the accessway shall be in accordance with Clause 13 of AS1428.1-2009.

3.2. Minimum 850mm clear opening width (generally required 920mm door leaf), measured from the face of the door to the door stop.
Note: where double doors are proposed, at least the active/operable leaf shall achieve the minimum 850mm clear opening width.

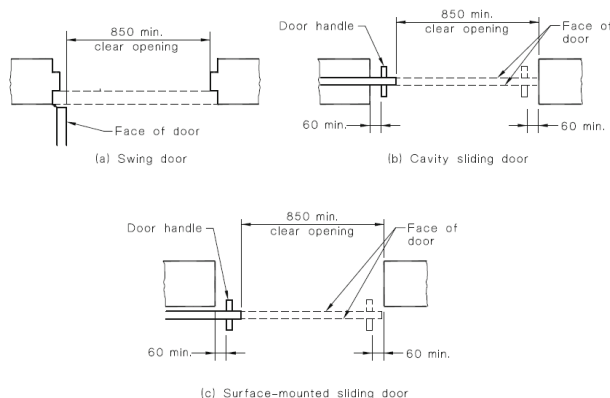

3.3. A minimum 30% luminance contrast shall be provided at doorways for ease of visual identification for people with vision impairment. The contrasting area (e.g. wall, architrave etc.) must have minimum 50mm width.

3.4. Every door and/or gate on the accessway shall be provided with circulation space on both sides to allow for operation of the door.

3.5. Circulation spaces shall be not steeper than 1:40. Refer to Figure 31 (hinged doors) and Figure 32 (sliding doors) of AS1428.1-2009 for the minimum required depth, latch-side and hinge-side circulation spaces as applicable.

3.6. Where surface-mounted sliding doors are proposed, the circulation spaces shall be increased by a factor of t as shown in Figure 33 of AS1428.1-2009.
Note: The factor t is the wall thickness to the face of the door.

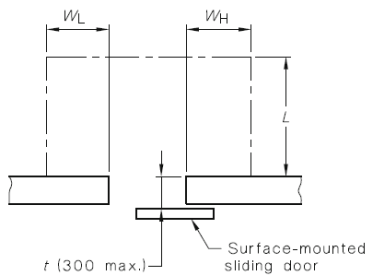

Door approach	Increase from Figure 32
Figure 32(d)	Add dimensions t to dimensions W_L and W_H
Figure 32(a), 32(b), 32(c)	Add dimensions t to dimensions L , W_L and W_H

3.7. Provide minimum 1450mm length between successive door swings in airlocks/vestibules or other similarly enclosed spaces on accessible path of travel.

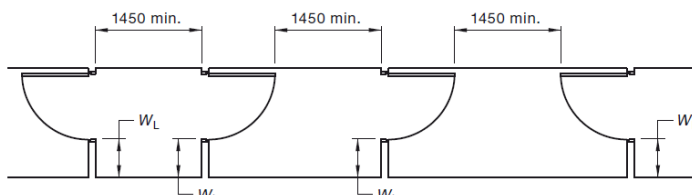

3.8. All fully glazed doors and surrounding glazing (including glazed walls with no transom or similar) shall be clearly marked with 75mm min. wide, solid, non-transparent, contrasting line across their full width. The lower edge of line must be between 900-1000mm FFL and have 30% luminance contrast when viewed against floor or background surface within 2m of glazing.

3.9. Door hardware shall:

3. DOORS

- (i) be a type that allows the doors to be operated with one hand;
- (ii) allow for adequate grip for people with hand impairments;
- (iii) have a clearance between the handle and the backplate or door face of 35-45mm;
- (iv) where snibs are installed, have a lever handle with minimum 45mm length from the centre of the spindle.

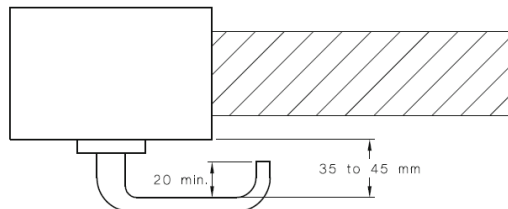

3.10. Door controls shall be located:

- (i) Door handles: 900-1100mm above FFL;
- (ii) Panic bars on egress routes: 900-1200mm above FFL;
- (iii) Intercoms, push buttons and the like: 900-1250mm above FFL and minimum 500mm from an internal corner;
- (iv) Handles on sliding doors shall be not less than 60mm from the door jamb or doorstop in the open or closed position;
- (v) Manual controls to power-operated doors (push buttons) shall be 1-2m from the door leaf (hinged or cavity-sliding doors) or clear of a surface-mounted sliding door in the open position.

Note 1: this is not applicable in early childhood centres, swimming pools and the like.

Note 2: Per BCA 2019 Clause D2.21, push buttons for emergency release power operated doors shall comply with item (iv) above. Braille and tactile signage in accordance with Clause 3 and 6 of Spec. D3.6 of the BCA is also required.

3.11. Door operational forces shall be not more than 20 N.

Note: If this cannot be achieved, the subject door shall be automated, or power operated.

3.12. A threshold ramp may be employed to address a maximum 35mm rise / FFL difference. Threshold ramp shall be in accordance with Clause 10.5 of AS1428.1-2009.

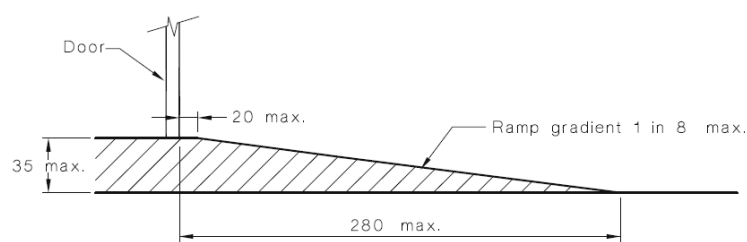

Note: Where ramp edges are not enclosed by walls/other side barrier, ensure ramp edges are splayed at 45 degrees.

4. STAIRWAYS

4.1. The requirements of this section shall apply to all stairways for general circulation and to external (non-fire isolated) egress stairways.

4.2. Stairs located at site boundary shall be recessed (900mm min. from boundary) to allow required handrail extensions and TGSIs to not protrude into transverse path of travel.

4. STAIRWAYS

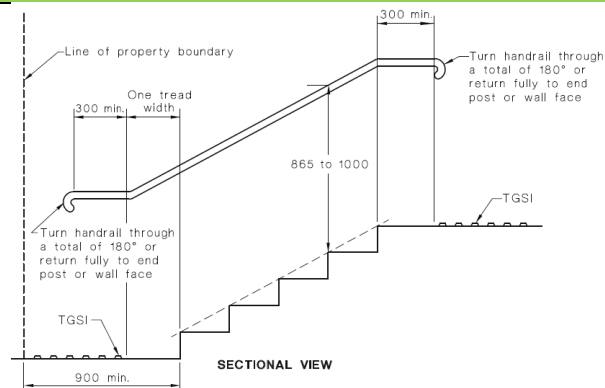

- 4.3. Stairs adjacent to internal corridors shall be recessed to allow required handrail extensions & termination to not protrude into transverse path of travel. The set-back shall be:
- 1 tread width plus handrail extension/turn down (approx. 650mm) at the bottom of a flight of stairs;
 - Handrail extension/turn down (approx. 400mm) at the top of a flight of stairs.

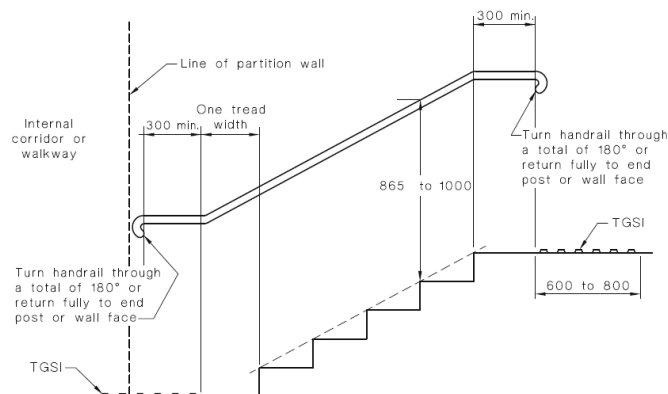

- 4.4. Minimum 1m clearance required between handrails.
- 4.5. Stairways shall have closed risers.
- 4.6. Stair nosings shall not project beyond the face of the riser. Risers shall be vertical or splay backwards a max. 25mm.
- 4.7. In order to achieve consistent height of the handrail along stairways, an offset tread is required at the bottom of the flight, as shown in Figure 28 of AS1428.1-2009.
- 4.8. Handrails compliant with Clause 12 of AS1428.1-2009 shall be provided to both sides of stairs. Refer to handrail section below for handrail requirements.
- 4.9. Handrail extensions are required at landings in accordance with the above:
- At the top of a flight of stairs: min. 300mm horizontal extension past the nosing;
 - At the bottom of a flight of stairs: one tread depth parallel to the line of nosings + min. 300mm horizontal extension;
 - Where the inner handrail is continuous at landings, the 300mm horizontal handrail extension is not required.
- 4.10. Provide warning tactile ground surface indicators (TGSIs) stairs landings in accordance with AS/NZS1428.4.1:2009. Refer to TGSIs section below for TGSIs requirements.
- 4.11. Provide contrasting step nosing strips on all stair treads compliant with AS1428.1 as follows:
- Step nosing strips to be across full width of stair, between 50-75mm wide, in a continuous colour solid strip with 30% luminance contrast to background surface.
 - Step nosing strips to be located on edge of tread (15mm max. setback if applied) and not extend onto risers more than 10mm. (if exposed).

4. STAIRWAYS

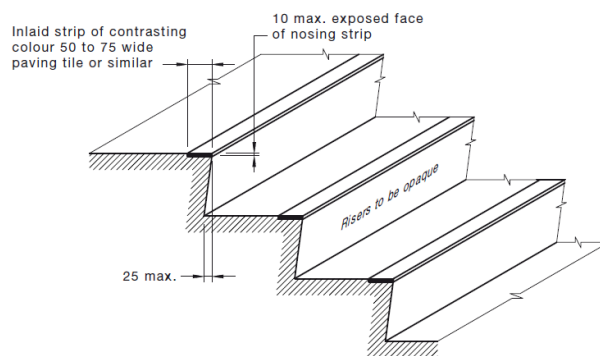

- 4.12. Where people can traverse under open stairs, a suitable barrier to the underside of the stairs shall be provided such that people do not traverse where the headroom is less than 2 meters. An example of a suitable barrier is illustrated in Figure 2.6(A) of AS/NZS1428.4.1:2009.

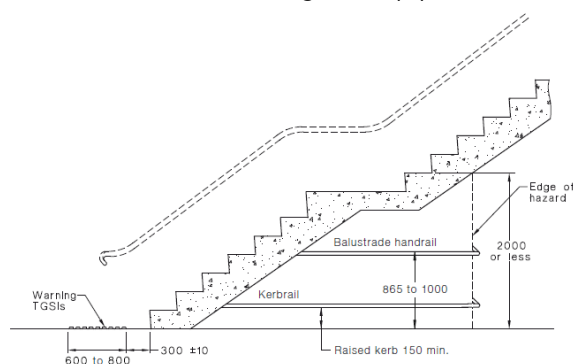

5. FIRE-ISOLATED STAIRWAYS

- 5.1. Provide contrasting step nosing strips on all stair treads compliant with AS1428.1 as follows:
- Step nosing strips to be across full width of stair, between 50-75mm wide, in a continuous colour solid strip with 30% luminance contrast to background surface.
 - Step nosing strips to be located on edge of tread (15mm max. setback if applied) and not extend onto risers more than 10mm. (if exposed).
- 5.2. Handrails compliant with Clause 12 of AS1428.1-2009 shall be provided to at least one side of stairs. Refer to handrail section below for handrail requirements.
- 5.3. In order to achieve consistent height of the handrail along stairways, an offset tread is required at the bottom of the flight, as shown in Figure 28 of AS1428.1-2009.
- 5.4. Minimum 1m clearance required between handrail and opposite wall.
Note: subject to BCA D1.6 relating to minimum requirements for exits.

6. RAMPS

- 6.1. Ensure a series of connected ramps does not exceed 3.6m vertical rise, in accordance with BCA Clause D3.11.
- 6.2. A ramp shall be not steeper than 1:14 and shall be constant throughout.
- 6.3. 1:14 walkways shall have suitable landings at 9m maximum intervals.
Note: for gradients other than 1:14, the maximum interval between landings shall be confirmed with Design Confidence.
- 6.4. Ramp landings shall be not steeper than 1:40.
- 6.5. Landings shall be:
- Minimum 1200mm length where there is no change in direction;
 - Where there is a change in direction, refer to Section 2 – Paths of Travel above;
 - Where there is a doorway, the landing shall be capable of accommodating the required doorway circulation spaces.

6. RAMPS

- 6.6. Ramps shall be set back from a transverse path of travel, being:
- Minimum 900mm set back at property boundary;
 - Minimum 400mm set back other than at property boundary.

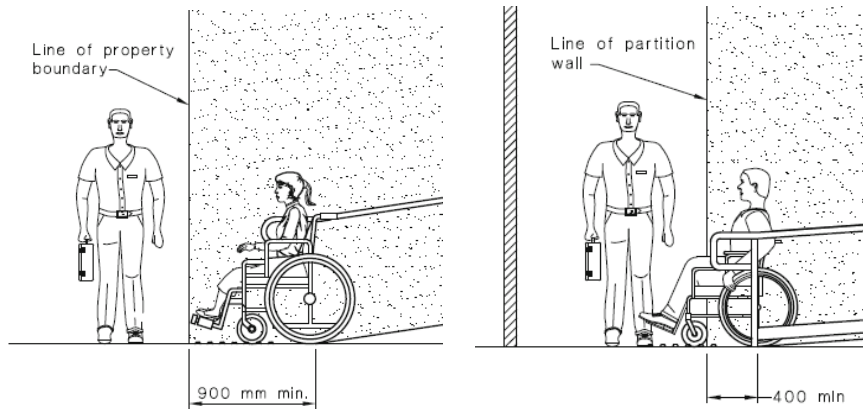

- 6.7. Handrails shall be provided on both sides of a ramp.

- 6.8. Handrail extensions are required at landings in accordance with the above:
- At the top and bottom landings: min. 300mm horizontal extension past the nosing;
 - Where the inner handrail is continuous at landings, the 300mm horizontal handrail extension is not required.

- 6.9. Ramps and intermediate landings shall have kerbs or kerb rails on both sides, being:
- Kerbing to be between 65-75mm height above FFL, or;
 - At least 150mm height above FFL;
 - The top of kerbing must not be within 75-150mm range above FFL to minimise risk of wheelchair footplate entrapment. If kerbing extends within 75-150mm range between it must be continuous with no gap greater than 20mm.

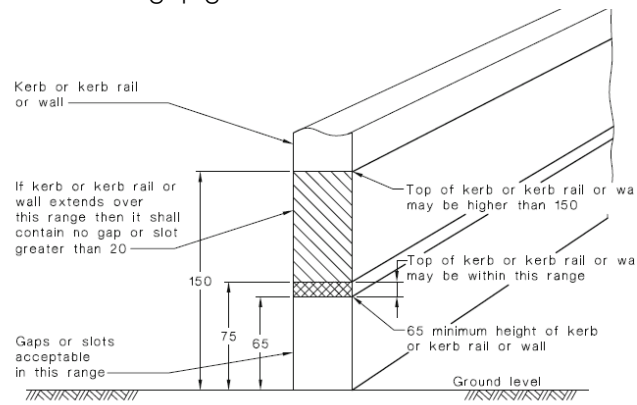

Note: where a handrail is wall mounted, the wall serves as a suitable side barrier, subject to the ramp-side face of the handrail being not more than 100mm from the wall (refer to Fig. 19 (d)).

- 6.10. The kerb to be suitably located in relation to handrail (and vertical supports if provided) i.e. Internal face of kerb in line with internal face of handrail or up to 100mm max. off-set inside the ramp, compliant with AS1428.1-2009 fig. 19.

6. RAMPS

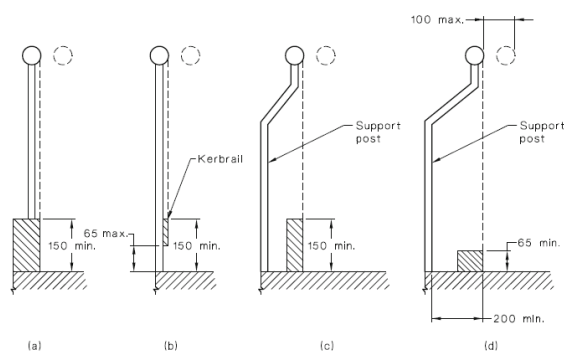

- 6.11. Provide warning tactile ground surface indicators (TGSIs) at top and bottom of ramps in accordance with AS/NZS1428.4.1:2009.
At intermediate landings, TGSIs are only required where the outer handrail is not continuous.
- 6.12. Curved ramps shall have 1500mm min. clear width with appropriate min. inside curve radius compliant with AS1428.1-2009 fig. 20.

7. HANDRAILS

- 7.1. All stairs and ramps shall be provided in accordance with Clause 12 of AS1428.1-2009, including fire-isolated stairways and ramps.
Note: for stairs/ramps in areas afforded the concession under D3.4, handrails are only required to comply with Clause D2.17 of the BCA.
- 7.2. The cross section of handrail shall be circular/elliptical handrails have 30mm - 50mm diameter, with 270-degree clear arc around top of handrail (extending for 600mm min. height) compliant with Figure 29 of AS1428.1-2009.

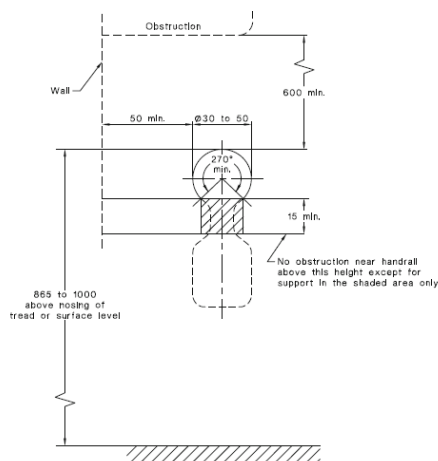

- 7.3. Handrails shall be installed at a consistent height between 865mm - 1000mm height above step nosing or FFL ramp surface.
NB. The specified height should allow for construction tolerance as outside of this range will be non-compliant.
- 7.4. Where a balustrade for fall protection is required at a height above 1m, both the balustrade and the handrails shall be provided.
- 7.5. Handrails shall have no vertical sections.
- 7.6. In order to achieve consistent height of the handrail along stairways, an offset tread is required at the bottom of the flight, as shown in Figure 28 of AS1428.1-2009.

7. HANDRAILS

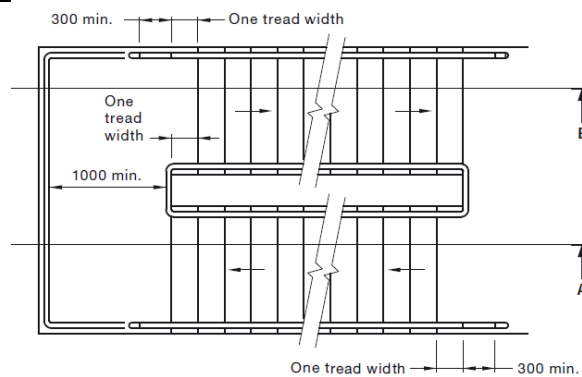

7.7. Handrails shall be installed no less than 50mm away from an adjacent side wall/ obstruction (finger clearance).

7.8. Refer to Stairs and Ramps sections for the requirements relating to handrail extensions.

7.9. Handrail ends shall be turned through a total of 180° OR to the ground OR returned fully to the end post/wall face. Suitable handrail ends are shown in Figure 26 (C) of AS1428.1-2009.

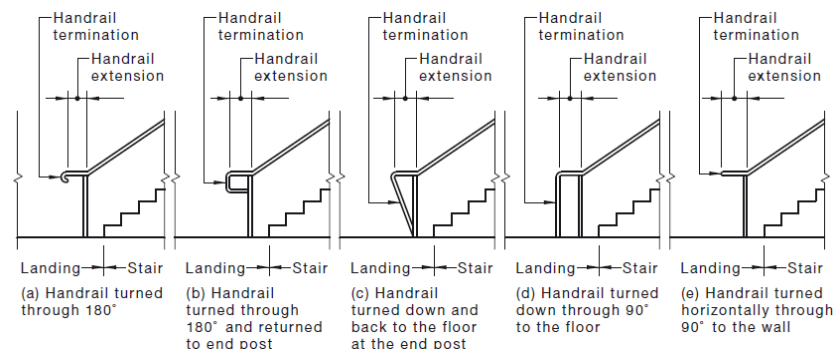

Note: fire-isolated stairs and ramps are not required to be provided with handrail extensions at landings, however handrail ends shall be in accordance with Figure 26 (C) of AS1428.1-2009 as shown above.

7.10. The inner handrail shall always be continuous at landings.

8. ACCESSIBLE PARKING

8.1. Minimum required dimensions:

- (i) Dedicated parking space shall be 2400mm W x 5400mm L (minimum);
- (ii) A shared area shall be provided to one side of the dedicated parking space, being 2400mm W x 5400mm L (minimum);
- (iii) A shared area shall be provided at one end of the parking space, being 2400mm W x 2400mm L.

8.2. The ground surface shall be firm, plane, slip resistant and traversable by people with disabilities (hence surfaces such as loose gravel and grass are not acceptable).

8.3. Accessible parking spaces and shared areas shall at the same grade and the ground surface shall be not steeper than 1:40 (1:33 for external bitumen surfaces is acceptable).

8.4. Vertical clearance leading to the accessible parking spaces shall be not less than 2200mm.

8.5. Vertical clearance at the accessible parking spaces and associated shared areas shall be not less than 2500mm.

Note: reduced headroom may be permitted in accordance with Figure 2.7 of AS/NZS2890.6:2009.

8. ACCESSIBLE PARKING

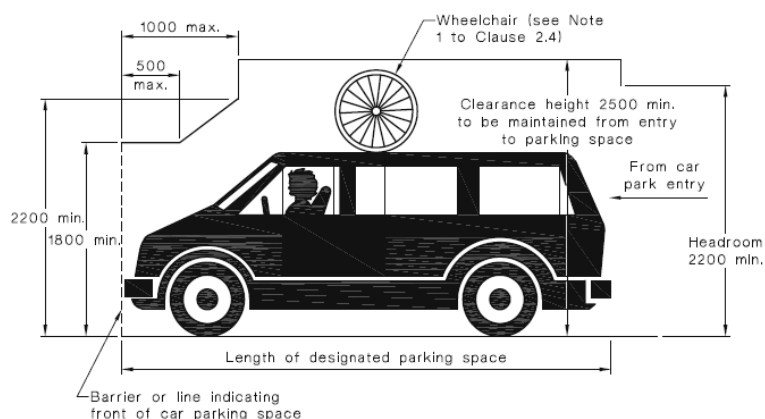

- 8.6. An accessible parking space shall be provided with pavement markings for identification, being the white symbol of access inside a blue rectangle with dimensions in accordance with Figure 3.1 of AS/NZS2890.6:2009.

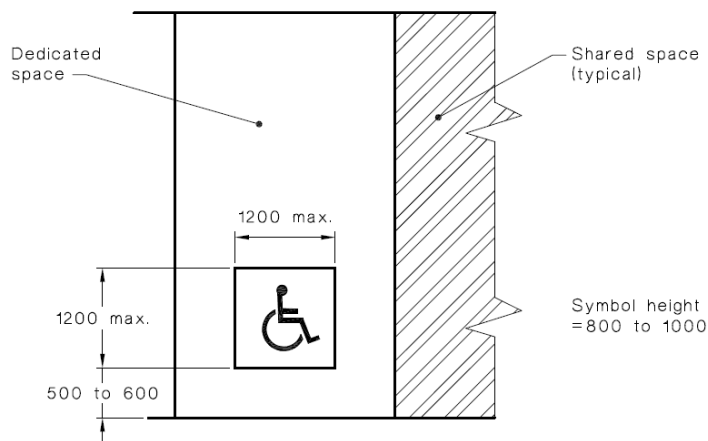

- Line markings shall be yellow, have a slip resistance surface and shall not be raised;
- The parking spaces and shared areas shall be outlined on all sides with an unbroken line 80-100mm wide, except where delineated by a kerb, barrier or wall;
- The shared areas shall be marked with diagonal stripes at an angle $45 \pm 10^\circ$ to the side of the space. The diagonal stripes shall be 150-200mm wide and spaced 200-300mm;
- No shared area markings shall be placed in trafficked areas (this is generally applicable to the 2400x2400mm shared area).

Note: the requirement for space identification is not applicable where:

- A total of not more than 5 parking spaces is provided;*
- An accessible parking space is privately owned parking space for people with disabilities associated with a single residence and intended primarily for use by the occupants of that residence (i.e. adaptable units).*

- 8.7. A bollard shall be provided within the shared area located in accordance with Figure 2.3 of AS/NZS2890.6:2009.

- 8.8. Residential accessible parking spaces are subject to the requirements of AS4299-1995.
Note: a parking space 3800mm W x 5400mm L is generally suitable for adaptable units.

9. SIGNAGE

- 9.1. Braille and tactile signage will be required to:
- Identify each sanitary facility, including an accessible sanitary facility and a sanitary compartment suitable for people with ambulant disabilities;
 - Identify each space provided with hearing augmentation;
 - Within each space provided with hearing augmentation;

9. SIGNAGE

- (iv) Identify each door required by BCA Clause E4.5 to be provided with an exit sign;
- (v) Identify a sanitary compartment suitable for people with ambulant disabilities;
- (vi) At entry doors to airlocks containing either accessible and/or ambulant WCs, identifying each facility provided within.

- 9.2. Braille and tactile directional signage will be required at:
- (i) A non-accessible pedestrian entrance to direct a person to the nearest accessible entrance;
 - (ii) A sanitary bank which is not provided with an accessible sanitary facility to direct a person to the nearest accessible sanitary facility.

9.3. Signage required to comply with Clause D3.6 of the BCA shall be in accordance with BCA Spec. D3.6 and Clause 8 of AS1428.1-2009.

9.4. Per BCA 2019, signage complying with Clause 3 and 6 of Specification D3.6 shall be provided to identify the latch-operation device (manual controls for power-operated doors).

- 9.5. At standard sanitary facilities, the signage shall include:
- (i) Minimum required message: "Male Toilet" or "Female Toilet", as applicable;
 - (ii) Raised & visual versions of the male and female symbols;
 - (iii) Braille that fully describes the information displayed by symbols and text.

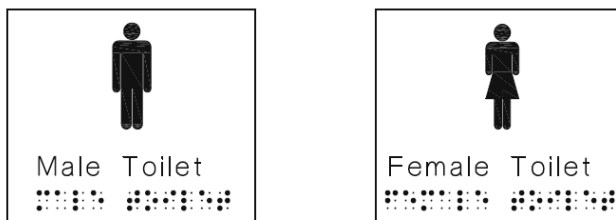

- 9.6. At an accessible sanitary facility, the signage shall include:
- (i) Minimum required message: "Unisex Toilet RH" or "Unisex Toilet LH" (as applicable)
 - (ii) Information if the toilet pan is suitable for RH or LH transfer;
 - (iii) Raised & visual versions of the international symbol of access;
 - (iv) Raised & visual versions of the male and female symbols;
 - (v) Braille that fully describes the information displayed by symbols and text.



- 9.7. At an ambulant sanitary compartment, the signage shall include:
- (i) Minimum required message: "Ambulant Male Toilet" or "Ambulant Female Toilet", as applicable;
 - (ii) Raised & visual versions of the male and female ambulant symbols;
 - (iii) Braille that fully describes the information displayed by symbols and text.

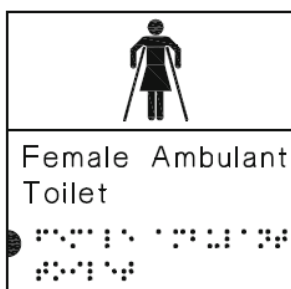

9. SIGNAGE

9.8. At exits, the signage shall include:

- (i) The word "Exit"; and
- (ii) The word "Level" and the floor level number OR a floor level descriptor OR a combination of both the number and the descriptor;
- (iii) Braille that fully describes the information display by text.

9.9. At the door to rooms/spaces provided with hearing augmentation, the signage shall include raised & visual versions of the international symbol of deafness.

9.10. Within the room/spaces provided with hearing augmentation, the signage shall include:

- (i) The type of hearing augmentation;
- (ii) The area covered within the room;
- (iii) If receivers are being used & where they can be obtained.

9.11. Directional signage shall include:

- (i) A wayfinding arrow that indicates the location of the subject accessible facility (being an accessible toilet or accessible entry);
- (ii) Raised & visual versions of the international symbol of access;
- (iii) Raised text that describes the subject accessible facility;
- (iv) If the accessible path of travel to the subject accessible facility is on a different level, include a symbol to denote travel via lift (if applicable).



9.12. Location of signage:

- (i) Braille and tactile components shall be at a height of 1200-1600mm above FFL; and
- (ii) On the wall on the latch-side of the door, leading edge of the sign 50-300mm from the architrave, except at ambulant sanitary facilities;
- (iii) Where b. is not possible, signage shall be on the door itself; and
- (iv) At ambulant sanitary facilities, the signage shall be placed on the door.

9.13. Minimum 30% luminance contrast between the wall/door to the backplate of the sign and between the backplate and the symbols, tactile and braille contained in the sign.

10. HEARING AUGMENTATION

10.1. Provide hearing augmentation in the following areas if an inbuilt amplification system is installed (except one used for emergency warning systems only):

- (i) Rooms in Class 9 buildings;
- (ii) Auditoriums, conference and meeting rooms, judicatory, and;
- (iii) Service counters screened to the public (e.g. reception, ticket/teller booths).

10.2. Hearing loops are required to at least 80% of floor area with inbuilt amplification system.

10.3. For Class 9b buildings, any screen or scoreboard that can display public announcements, to be capable of supplementing the public address system (excluding emergency warning only).

11. TACTILE GROUND SURFACE INDICATORS (TGSIs)

- 11.1. Ensure that TGSIs are slip-resistant and achieve minimum luminance contrast against background surface in accordance with the following:
- (i) Integrated TGSIs (i.e. tiles) require 30% min. luminance contrast.
 - (ii) Discrete TGSIs (i.e. buttons) require 45% min. luminance contrast.
 - (iii) Composite TGSIs with 2 materials/colours requires 60% min. luminance contrast.
- 11.2. Ensure that warning TGSIs extend across the full width of the path of travel and commence 300mm from the edge of stairs, ramps etc.
- Note 1: tactile indicators are **not** required where the gradient is not steeper than 1:20 (walkways) or at step ramps and kerb ramps.*
- Note 2: tactile indicators are **not** required at fire-isolated stairs and ramps.*
- Note 3: tactile indicators **are** required at external (non-fire-isolated) egress stairs and ramps.*
- 11.3. Ensure that warning TGSIs have between 600mm - 800mm depth at open areas, or at landings >3m length and/or when handrail is discontinuous.
- 11.4. Ensure that warning TGSIs have between 300mm - 400mm depth at enclosed landings (<3m) when external handrail is discontinuous.
- 11.5. Where a pedestrian pathway and vehicular way are at the same level (i.e. no kerb provided), warning tactile indicators shall be provided.

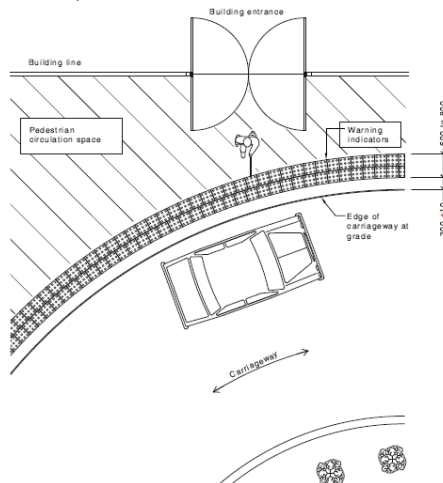

- 11.6. TGSIs may be provided in lieu of a barrier to the underside of stairs where the headroom is less than 2 meters.

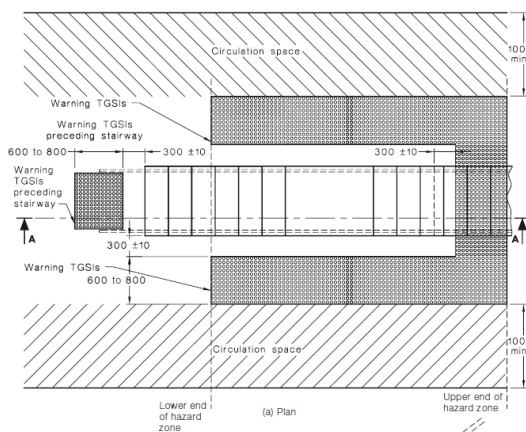

12. PASSENGER LIFTS

- 12.1. All passenger lifts are required to be of a type in accordance with BCA Table E3.6a, have accessible features in accordance with BCA Table E3.6b and shall not rely on a constant pressure device for operation if the lift car is fully enclosed.
- 12.2. Passenger lifts travelling more than 12m require 1400mm W x 1600mm L min. dimensions.
- Note: a concession is available for existing lifts in existing building, subject to the requirements of the Disability (Access to Premises – Buildings) Standards 2010.*

12. PASSENGER LIFTS	
12.3.	Passenger lifts travelling less than 12m (except stair platform lifts) require 1100mm W x 1400mm L min. dimensions.
12.4.	Stairway platform lifts (previous AS1735.7) require 810mm W x 1200mm L min. dimensions, compliant with BCA Part E3.6. Note: the use of stairway platform lifts is subject to a case-by-case assessment.
12.5.	Low-rise platform lifts (previous AS1735.14), require 1100mm W x 1400mm L min. dimensions compliant with BCA Part E3.6 and must not travel more than 1000mm height variation.
12.6.	Low rise, low speed constant pressure lifts, unenclosed type (previous AS1735.15), require 1100mm W x 1400mm L min. dimensions compliant with BCA Part E3.6 and must not travel more than 2m. They cannot be used high traffic public areas.
12.7.	Low rise, low speed constant pressure lifts, enclosed type (previous AS1735.15), require 1100mm x 1400mm min. dimensions compliant with BCA Part E3.6 and must not travel more than 4m. They cannot be used high traffic public areas.
12.8.	Any low-rise lifts (previous part AS1735.14 or 15) that require constant pressure to be applied to the lift control buttons to either call and/or operate the lift (i.e. Press and Hold) are to include signage to explain operations of use.
12.9.	Small size low-speed automatic lifts (previous AS1735.16), require 1100mm W x 1400mm L min. dimensions and must not travel more than 12m.
12.10.	Ensure all passenger lifts (except stair platform lifts) have 900mm min. clear door opening, compliant with AS1735.12.
12.11.	Ensure all Low-rise platform and Low rise, low speed constant pressure lifts with manual door opening (previous AS1735.14, 15 and 16) have suitable door circulation areas compliant with AS1428.1.
12.12.	Ensure the centre line of standard lift call buttons in all lift lobbies are located at height of 900-1200mm and at least 500mm distance from an internal corner to be accessible to people using wheelchairs, compliant with AS1735.12.
12.13.	Ensure all passenger lifts (except stair platform and low-rise platform lifts) include an internal lift control panel with centre line of control buttons located at a height no less than 700mm and no greater than 1250mm above FFL. The components of the floor level buttons shall possess Braille, raised tactile symbols and numbers, visual and auditory indicators, compliant with AS1735.12. <i>Advisory note: horizontal lift control panels are preferred over vertical panels for ease of reach as they generally can be positioned with control buttons within 900-1100mm FFL which is the preferred range for most wheelchair users.</i>
12.14.	Ensure all passenger lifts (except stair platform and low-rise platform lifts) include 2 x lift control panels when the width/length dimension is less than 1400mm.
12.15.	Ensure all passenger lifts (except stair platform and low-rise platform lifts) include an internal handrail installed at a height 850-950mm. The handrail ends shall be no more than 500mm away from any operating device or button.
12.16.	Ensure all passenger lifts (except stair platform lifts) include emergency hands free communication, including a button to alert call centre of a problem and a signal light to confirm that call has been received.
12.17.	Ensure all lifts serving more than 2 levels provides automatic audible information within the lift car to identify each level the lift stops.
12.18.	Ensure all lifts serving more than 2 levels provides appropriate visual and audible arrival signals of the lift car in all lift lobbies.
12.19.	Ensure all lifts serving more than 2 levels provides appropriate audible range and frequency, (between 20-80dbA at maximum frequency of 1500 Hz).
12.20.	The lighting in all enclosed lift cars must be at least 100 lux.
12.21.	All visible information to provide 30% min. luminance contrast to background surface.

13. ACCESSIBLE SANITARY FACILITIES	
13.1.	Provide 1 unisex accessible toilet at each bank of male/female toilets on each storey compliant with BCA Table F2.4a.

13. ACCESSIBLE SANITARY FACILITIES

NB. Where more than 1 toilet bank on each storey provide an accessible facility at 50% of banks.

13.2. Ensure a balance of left- and right-handed WC pans within the building.

13.3. Circulation space associated with the toilet pan min. 1900mm W x 2300mm L. The washbasin is permitted to encroach a max. 100mm within the WC circulation space in accordance with Figure 43 of AS1428.1-2009.

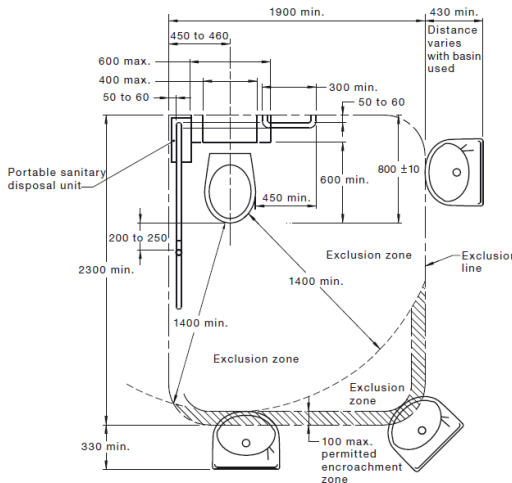

13.4. The required circulation spaces associated with toilet pan, washbasin, shower and door are allowed to overlap.

13.5. The washbasin is permitted to encroach into the doorway circulation space, however a min. 300mm is required between the door swing (for a hinged door) and the washbasin. Other fixtures such as toilet pan and shower seat are not allowed within the door circulation.

13.6. The centreline of the accessible toilet pan shall be 450-460mm from side wall.

13.7. Toilet projection from the back wall to the front of the toilet seat shall be 800mm ± 10mm.
Note: This is a critical dimension.

13.8. The height to top of the toilet seat shall be 460-480mm above FFL.

13.9. The toilet seat shall achieve 30% luminance contrast against background (e.g. pan, wall or floor surface).

13.10. Provide grabrails on wall of toilet at a height of between 800-810mm (to top of grabrail) above FFL.

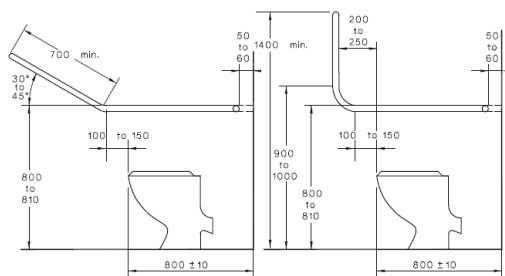

(a) Side view showing optional systems for grabrail at sides of pan

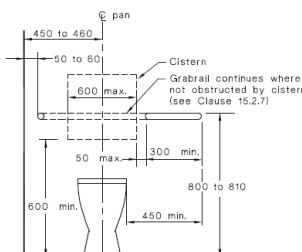

Note: If concealed cistern used, WC grab-rails are to be continuous across side and rear walls. If exposed cistern used, rear grabrail to commence 50mm max. from cistern edge.

13. ACCESSIBLE SANITARY FACILITIES

- 13.11. Provide angled toilet backrest (350-400mm W x 150-200mm H) installed between 120-150mm height from top of pan seat and 50mm max. distance from seat bolt hole.
NB. No toilet lid to be provided as this impedes use of back rest.

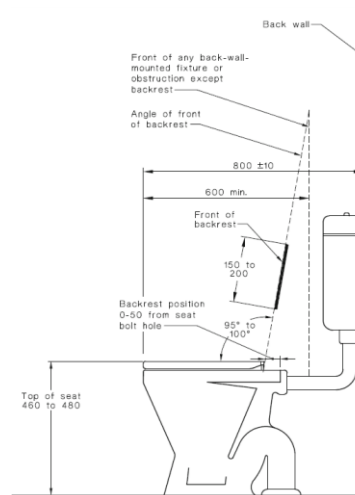

- 13.12. Flushing controls shall be located in accordance with Figure 40 of AS1428.1-2009.

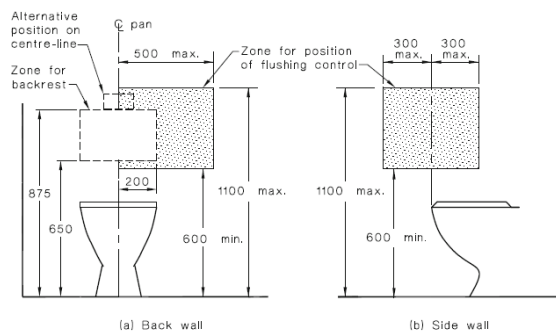

- 13.13. Toilet roll holder to be installed on adjacent wall to toilet at 600mm centre-line height from FFL within 300mm max. length from front of pan and no closer than 50mm to grabrail.

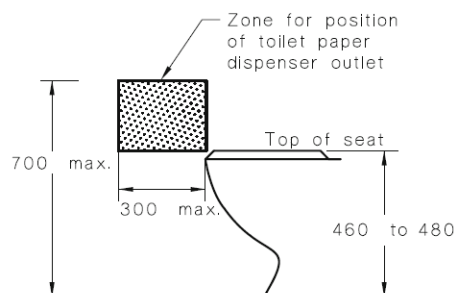

- 13.14. The centreline of the basin shall be min. 425mm from side wall.
- 13.15. The height of the basin shall be 800-830mm from FFL with lever action taps and insulation of water pipes.
- 13.16. Provide basin with a 430mm min. depth projection (from back wall to front of the basin) and suitable wheelchair knee/toe height clearance, compliant with Figure 44 of AS1428.1-2009. Knee/toe clearance shall be clear of water supply and/or sewage pipes.

13. ACCESSIBLE SANITARY FACILITIES

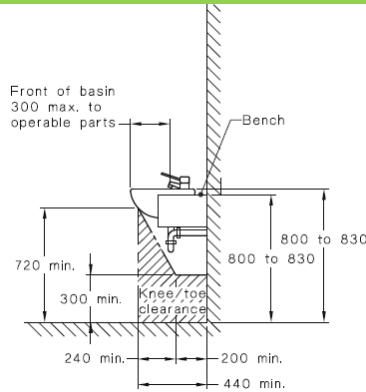

13.17. Washbasin shall have min. 450mm width and circulation space in accordance with Figure 44 of AS1428.1-2009.

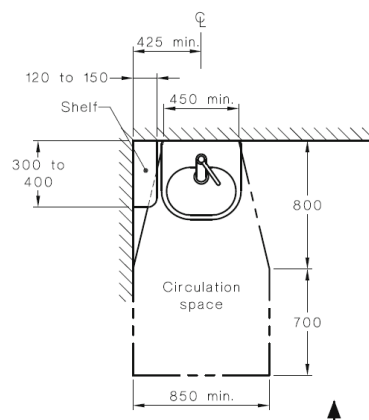

13.18. 300mm max. distance from the front of the basin to the operable part of taps.
Note: operable parts of taps shall be understood as the tap handle (for its full arc of operation) OR the position where a sensor is reliably activated AND the water spout.

13.19. Provide separate fixed shelf (120mm - 150mm W x 300mm - 400mm L) next to wash basin, installed at 900mm - 1100mm above FFL.
Shelf space may also be provided as a vanity top, min. 120mm W x 300mm L.

13.20. Provision of soap dispenser, hand drier or paper towel dispenser shall be installed at a height of 900-1100mm to the operative component.
Note: it is recommended that soap dispenser and hand dryer/paper towel dispenser are within reach from the washbasin (for example, that would allow for a wheelchair user not to need to move away from washbasin to dry hands).

13.21. Provide mirror above washbasin, with base installed at 900mm max. above FFL and extending to a height not less than 1850mm. The width of the mirror shall be min. 350mm.

13.22. 1 x clothes hanging device to be installed between 1200-1350mm from FFL and at least 500mm from an internal corner.

13.23. Door shall include an in-use indicator and a bolt/catch that can be opened from outside in an emergency. If snib turn is used, the handle shall be 45mm min from centre.

13.24. A baby change table (if provided) cannot impede into required circulation spaces (when folded up). The top of table to be installed at 820mm height with 720mm min. under bench clearance above FFL.

13.25. Light switches to be installed 900-1100mm above FFL and 500mm min. from internal corner.

13.26. GPO's to be installed 600-1100mm above FFL and 500mm min. from internal corner.

13.27. Rocker action/toggle type switches at least 30mm x 30mm dimensions are required to assist people with dexterity impairment.

13.28. Accessible shower shall be hobless/step-free.

13.29. Minimum dimensions of the shower recess 1100mm (side wall) x 1160mm (back wall).

13.30. The circulation space associated with the shower shall be in accordance with Figure 47 of AS1428.1-2009.

13. ACCESSIBLE SANITARY FACILITIES

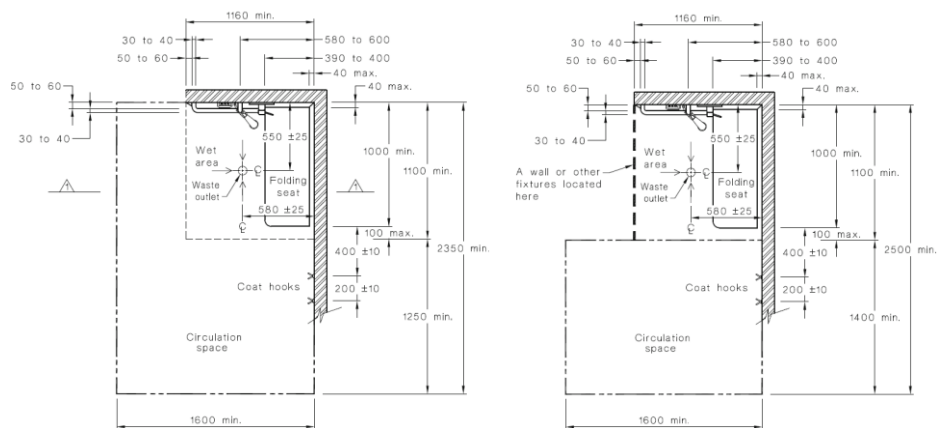

- 13.31. All accessible showers have shower rail/curtain installed.
Note: if shower screens are proposed, it shall be clear of the minimum circulation space (min. 1600 x 2350mm). Moreover, the shower door shall be in accordance with Clause 13 of AS1428.1-2009.
- 13.32. The height to the top of shower seat shall be 470-480mm above FFL.
- 13.33. Provide a horizontal grab rail (660mm min), to be placed beneath the vertical shower support rail, between 390-400mm from side wall (leading edge of grabrail aligned with end of shower seat), installed 800-810mm height from FFL.
- 13.34. Provide vertical shower support rail to start between 1000-1100mm from FFL. The top of the shower support rail to finish between 1880-1900mm FFL. The rail to be placed between 580-600mm from the side wall.
- 13.35. Ensure the shower taps and soap holders to be placed between 900mm - 1100mm from FFL. The shower taps and soap holders shall be 300-800mm from side wall and there shall be 50mm clear from the vertical support grabrail.
- 13.36. Hand-held shower head required, with flexible hose min. 1500mm in length.
- 13.37. The height of the hose wall outlet to be 700±5mm height above FFL to ensure suitable hose length when showering. A suitable back-flow prevention device shall be provided.
- 13.38. Provide 2 x clothes hanging devices required outside the shower recess. First hook shall be 400mm from the edge of the toilet seat and the second hook shall be 600mm from the edge of the seat, installed between 1200-1350mm from FFL.

14. AMBULANT SANITARY FACILITIES

- 14.1. Ambulant facilities for males and females shall be provided at each bank of toilets where there are one or more toilets in addition to an accessible WC.
- 14.2. Minimum 900mm x 900mm circulation area shall be provided between successive door swings in airlocks/vestibules on path of travel leading to ambulant toilets.
- 14.3. Minimum 900mm x 900mm circulation area shall be provided outside the ambulant cubicles.
- 14.4. The cubicle shall be between 900mm - 920mm clear width with WC pan centred (i.e. 450-460mm set out).
- 14.5. The cubicle door shall have a min. 700mm clear opening width.
- 14.6. 900mm x 900mm clear area shall be provided in front of WC pan and clear of door swing.
- 14.7. Projection of WC (distance from back wall to the front of the seat) shall be 610-660mm.
- 14.8. Height to top of pan seat shall be 460-480mm above FFL.
- 14.9. Ambulant cubicle door shall be provided with in-use indicator and bolt/catch that is able to be opened from outside (in emergency). If snib catch used, the handle shall be 45mm min. length from centre.
- 14.10. Grabrails provided on both sides of cubicle at 800mm - 810mm height (to top of grabrail) from FFL.
 Refer to Figure 53 (A) of AS1428.1-2009 for further guidance.

14. AMBULANT SANITARY FACILITIES

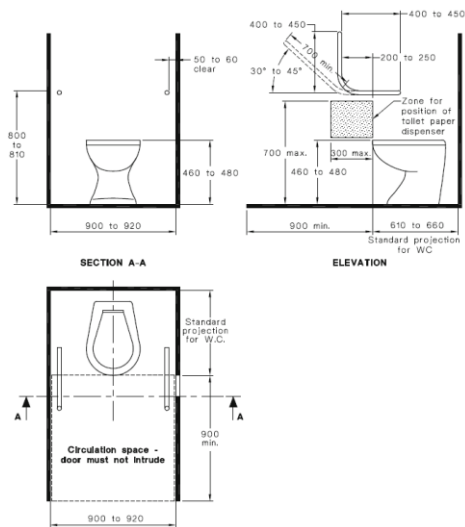

14.11. Toilet roll holder to be placed at 700mm max. height from FFL and 300mm max. distance from front of pan on adjacent wall, no closer than 50mm to grabrails.

14.12. Clothes hook to be installed between 1350mm - 1500mm from FFL.

15. GRABRAILS

15.1. Grabrails shall have 30-40mm outside diameter.

15.2. Grabrails shall be installed 800-810mm height to the top of grabrail.

15.3. Grabrails shall be able to withstand a force of 1100N applied at any position and in any direction.

15.4. The clearance between the face of the grabrail and the wall shall be 50-60mm (finger/knuckle clearance).

15.5. 270-degree clear arc around top of handrail required (extending for 600mm min. height above the grabrails).

APPENDIX 3 – Inclusive Design Recommendations

The following design guidance checklist includes recommendations which may be implemented in order to add value to the project in relation to enhanced accessibility provisions.

1. INCLUSIVE / UNIVERSAL DESIGN RECOMMENDATIONS	
1.1.	There are multiple bars proposed. As a common facility, the bars that provide different services should be made accessible by providing a lower section of the service counter to include the following: <ul style="list-style-type: none"> (i) The lower section of the counter to be at 850mm±20mm AFFL (ii) Knee clearance of not less than 720mm in height
1.2.	It should be considered to provide a minimum 1200mm between furniture (fixed or loose) to allow an accessible path of travel throughout the building.
1.3.	A different selection of seating options is recommended throughout the building to cater for people with ambulant disabilities.
1.4.	The proposed kids playground area, located east of the subject building is recommended to be provided with inclusive elements to cater for a diverse range of occupants, with reference made to the Everyone Can Play (ECP) Guideline prepared by NSW Government.

APPENDIX 4 – Drawing Mark-ups

Design Confidence Pty Limited

Shop 2, 35 Buckingham Street, Surry Hills NSW 2010
ABN: 72 896 582 485

T: (02) 8399 3707
E: sydney@designconfidence.com
W: www.designconfidence.com

This document is and shall remain the property of Design Confidence. The technical and intellectual content contained herein may only be used for the purpose for which it was commissioned and in accordance with the Terms of Engagement for the commission.

Unauthorised use of this document in any form whatsoever is prohibited.