

Report Type: DA Access Report
Reference Number: 19024
Client: Stema Pty Ltd
Site Address: 28-32 Evan Street, Penrith NSW



ACCESS REPORT

Vista Access Architects



Company Details

Vista Access Architects Pty. Ltd
ABN 82 124 411 614 ARN 6940
ACAA 281, CP 006, LHA 10032

Postal Address

POBox 353
Kingswood
NSW 2747

Contact details

www.accessarchitects.com.au
admin@accessarchitects.com.au
Farah Madon 0412 051 876

Project Summary:

This Access Compliance Report is to accompany a Development Application for the development proposed at 28-32 Evan Street, Penrith NSW.

This development proposes a New Building with a total of 40 Residential units. The development is within Penrith Council LGA that requires the provision of 10% Adaptable units and therefore the development proposes 4 Adaptable units. A total of 4 Accessible parking spaces have been provided in the development.

The project also provides 8 Livable units to comply with the SEPP 65 Objective 4Q1, that requires 20% of the units to incorporate the features of the Silver level of the Livable Housing Guidelines.

The development has building classification as detailed below;

- Class 2 (building containing more than 2 SOUs i.e. sole-occupancy units)
- Class 7a (car park)

This Access report is based on the relevant components of;

- Building Code of Australia (BCA) 2016, Volume 1- Performance requirements of DP1, DP2, DP8, DP9, EP3.4, FP2.1 and Parts D2, D3, E3 and F2 (where applicable)
- Disability (Access to Premises-Building) Standards 2010 (henceforth referred to as APS)
- AS1428.1-2009 Part 1: General requirements for access, including any amendments
- AS1428.4.1-2009 Part 4.1: TGSIs (Tactile ground surface indicators), including any amendments
- AS2890.6-2009 Part 6: Off-street parking for people with disabilities.
- AS4299-1995 Adaptable Housing
- AS1735 Lifts types included in the BCA including Part 12: Facilities for persons with disabilities
- State Environmental Planning Policy 65 (SEPP 65), Objective 4Q1, relating to requirements of the provision of Livable Housing Australia's Silver Level Apartments
- Livable Housing Australia's Livable Housing Design Guidelines- Fourth Edition

The assessment of the proposed development has been undertaken to the extent necessary to issue DA (Development application) consent under the Environmental Planning and Assessment Act. The proposal achieves the spatial requirements to provide access for people with a disability and it is assumed that assessment of the detailed requirements such as assessment of internal fit-out, details of stairs, ramps and other features will occur at CC (Construction Certificate) stage.

By compliance with the recommendation in this report, the development complies with the requirements of Access Code of Disability (Access to Premises-Building) Standards 2010, the Disability Access relevant sections of Building Code of Australia 2016, the requirements of SEPP 65 related to Objective 4Q1 - Livable Housing, and the essential criteria of AS4299-Adaptable Housing.

ASSESSED BY



Vanessa Griffin

*Accredited Access Consultant and LHA Assessor
ACAA Accredited Membership number 500
LHA Assessor Licence number 20035*

PEER REVIEWED BY



Farah Madon

*Accredited Access Consultant and LHA Assessor
ACAA Accredited Membership number 281
LHA Assessor Licence number 10032*

Vista Access Architects Pty. Ltd.

Relevant dates:

Fee proposal, number FP-9040 dated 06-02-2019. Fee proposal was accepted by Client on 11-02-2019.

Assessed Drawings:

The following drawings by Morson Group Architects have been assessed for compliance.

Drawing no	Issue	Date	Details
DA05	P4	02-04-2019	Ground Level
DA06	P4	02-04-2019	Level 1
DA07	P4	02-04-2019	Level 2
DA08	P4	02-04-2019	Level 3
DA09	P4	02-04-2019	Level 4
DA10	P4	02-04-2019	Level 5
DA12	P4	02-04-2019	Basement 1
DA13	P4	02-04-2019	Basement 2

Document Issue:

Issue	Date	Details
Draft 1	15-02-2019	Issued for Architect's review
A	10-04-2019	Issued for Development Application

Limitations and Copyright information:

This report is based on discussions with the project architect and a review of drawings and other relevant documentation provided to us. No site visit was undertaken for the purposes of this project.

This assessment is based on the provided drawings and not based on constructed works, hence the assessment will provide assurance of compliance only if all the recommendations as listed in this report are complied with and constructed in accordance with the requirements of the current BCA, AS1428.1-2009 and other latest, relevant standards and regulations applicable at the time of construction. Assessment is based on classification/use of the building. If the Class of the building changes to any other building Class, this access report will have to be updated accordingly.

Unless stated otherwise, all dimensions mentioned in the report are net (CLEAR) dimensions and are not be reduced by projecting skirting, kerbs, handrails, lights, fire safety equipment, door handles less than 900mm above FFL (finished floor level) or any other fixtures/fit out elements. When we check drawings, we assume that the dimensions noted are CLEAR dimensions and therefore the Architect / Builder is to allow for construction tolerances. Only some numerical requirements from relevant AS (Australian Standards) have been noted in the report and for further details and for construction purposes refer to the latest relevant AS.

This report and all its contents are a copyright of Vista Access Architects Pty Ltd (VAA) and can only be used for the purposes of this particular project. This document may also contain Standards Australia Ltd copyrighted material that is distributed by SAI Global on Standards Australia Ltd.'s behalf. It may be reproduced in accordance with the terms of SAI Global Ltd.'s Licence 1901c001. Standards Australia Ltd.'s material is not for resale, reproduction or distribution in whole or in part without written permission from SAI Global Ltd.

This report is does not assess compliance matters related to WHS, Structural design, Services design, Parts of DDA other than those related to APS or Parts of BCA or Parts of AS other than those directly referenced in this report. VAA gives no warranty or guarantee that this report is correct or complete and will not be liable for any loss arising from the use of this report. We will use our best judgement in regards to the LHA assessments. However, we are not to be held responsible if another licenced LHA assessor comes to a different conclusion about compliance, certification or allocation of a particular Quality mark to us as a number of items are subject to interpretation.

We have no ability to check for slip resistance of surfaces. All wet areas, parking areas, pavement markings shall have the appropriate slip resistance for the location. We also have no ability to check for wall reinforcements once the walls have already been constructed. The builder is to take full responsibility that the requirements listed in this report are met and the construction to be as per requirements of AS1428.1/ AS4299 / AS2890.6/ AS3661/ AS4586

A report issued for DA (development application) is not suitable for use for CC (construction certificate) application.

Compliance assessment with Access related requirements of BCA and Disability (Access to Premises-Building) Standards 2010 (APS)

BCA Part D3 Access for People with a Disability

	BCA D3.1 General building Access requirements SOU refers to a Sole Occupancy Unit
Requirement	Class 2 For residential use components, access is required: <ul style="list-style-type: none"> - From a required accessible pedestrian entrance to at least 1 floor with SOUs and till the entry of door of each SOU on that level. - To and within 1 of each type of room or space in common use. - Where floor is accessed by an AS1428.1 ramp or lift, access is required to the entry doorway of each SOU on that level and to and within all common use areas on that level.
Compliance Comments	Complies <ul style="list-style-type: none"> - Access has been provided from the main pedestrian entry doorway to the entry doors of all SOUs on all levels by means of accessible pathways and lifts. - Access has been provided to at least 1 of each common use space such as communal garden and Common room on Ground floor level. - Access has been provided to common use garbage chutes on each floor level. - Access has been provided to storage units in basement. Details to be verified at CC stage of works.
Requirement	Class 7a- Covered car park. <ul style="list-style-type: none"> - To and within any level containing accessible carparking spaces.
Compliance Comments	Complies Access has been provided to Basement level containing Accessible carparking spaces. Details to be verified at CC stage of works.
	BCA Part D3.2 Access to buildings
Requirement	Accessway is required from; <ul style="list-style-type: none"> - Main pedestrian entry at the site boundary for new buildings. - Any other accessible building connected by a pedestrian link. - Accessible car parking spaces.
Compliance Comments	Complies <ul style="list-style-type: none"> - Access by means of 1:20 grade walkways has been provided from the main pedestrian entry at the site boundary. - Access has been provided from accessible car parking spaces by means of lifts. Details to be verified at CC stage of works.
Requirement	External Walkway / Pedestrian Access- to be as per requirements of AS1428-2009.
Compliance Comments	Capable of compliance. Details to be verified at CC stage of works.
Requirement	Accessway is required through: <ul style="list-style-type: none"> - Main entry; and - Not less than 50% of all pedestrian entrances; and - In building with floor area over 500m², non-accessible entry and accessible entry to be not more than 50M apart.
Compliance Comments	Complies The building has only 1 pedestrian entry, which has been designed to be accessible. Details to be verified at CC stage of works.

Requirement	Where accessible pedestrian entry has Multiple doorways : <ul style="list-style-type: none"> - At least 1 to be accessible if 3 provided - At least 50% to be accessible, if more than 3 provided - Where doorway has multiple leaves, at least 1 leaf is to have clear opening of 850mm (excluding automatic doors)
--------------------	--

Compliance Comments	Capable of compliance. In common use areas, all single hinged doors and in case of multiple leaf doorways, at least 1 operable leaf is required to provide a clear opening of 850mm with the door circulations spaces as per AS1428.1-2009.
----------------------------	--

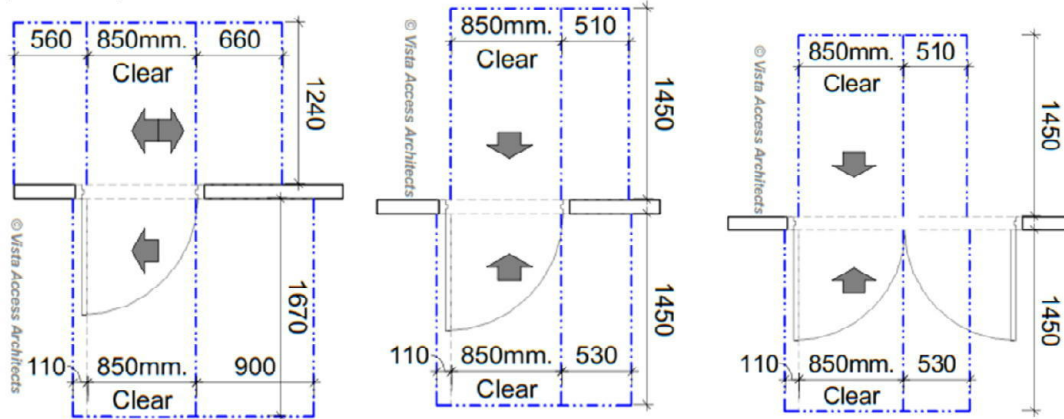

Note that the circulation spaces (other than doorway threshold ramp) to have a maximum floor grade of 1:40. Where there is a level difference at the door threshold, the maximum level difference can be 35mm if provided with a 1:8 doorway threshold ramp. This is achievable and the door selections are to be verified at CC stage of works.

BCA Part D3.3 Parts of buildings required to be accessible

Requirement	Every Ramp with grades steeper than 1:20 and less than or equal to 1:14 (excluding fire-isolated ramp) is to be compliant with: <ul style="list-style-type: none"> - AS1428.1-2009 (including but not limited to - maximum grade of 1:14 with appropriate landings at a maximum of 9M of a flight of ramp). - 1M clear width to be provided between handrails / kerb / kerbrails. - Handrails and kerbs to be provided on both sides with appropriate handrails extensions. - Slip resistance of ramp and landings to comply with BCA Table D2.14
--------------------	--

Compliance Comments	N/A No 1:14 ramps have been identified in the development.
----------------------------	---

Requirement	Step ramp if provided is to be compliant with: <ul style="list-style-type: none"> - AS1428.1-2009 including max grade of 1:10, max height of 190mm, max length of 1.9M - Slip resistance of ramp and landings to comply with BCA Table D2.14.
--------------------	--

Compliance Comments	N/A No step ramps have been identified in the development.
----------------------------	---

Requirement	Kerb ramp if provided is to be compliant with: <ul style="list-style-type: none"> - AS1428.1-2009 including max grade of 1:8, max height of 190mm, max length of 1.52M - Slip resistance of ramp and landings to comply with BCA Table D2.14.
--------------------	--

Compliance Comments	N/A No kerb ramps have been identified in the development.
----------------------------	---

Requirement	<p>Every Stairway (excluding fire-isolated stairway) is to be compliant with:</p> <ul style="list-style-type: none"> - AS1428.1-2009 (including but not limited to opaque risers, handrails on both sides including appropriate handrail extensions between 1M clear width and compliant nosing strips). - Slip resistance to comply with BCA Table D2.14 when tested in accordance with AS4586.
Compliance Comments	<p>Capable of compliance</p> <p>Where non-fire-isolated stairways have been provided, the features of the stairway will be assessed with the requirements of AS1428.1-2009 at the CC stage of works.</p> <p>Note: In some cases, the stairway from the basement to the ground floor level is considered to be non-fire-isolated, in which case full compliance will be required as per AS1428.1-2009. Verify with the BCA consultant.</p>
Requirement	<p>Handrail cross-section – for stairways and ramps to comply with AS1428.1-2009.</p> <ul style="list-style-type: none"> - Diameter of handrails to be between 30mm-50mm and located not less than 50mm from adjacent walls with no obstructions to top 270° arc.
Compliance Comments	<p>Capable of compliance.</p> <p>Details to be verified at CC stage of works.</p>
Requirement	<p>Every Fire-isolated Stairway is to be compliant with AS1428.1-2009 in the following aspects:</p> <ul style="list-style-type: none"> - Handrail on one side (requirement under D2.17) with 1M clear space. Handrail extensions are not required however since the handrails cannot have any vertical sections and since handrail is required to be at a consistent height throughout the stairway including at landings, it may be essential to either provide handrail extensions or offset first riser going up at mid landings to achieve this at 90° to 180° turns. - Nosing strips 50mm-75mm wide with minimum of 30% luminance contrast and - Slip resistance to comply with BCA Table D2.14.
Compliance Comments	<p>Capable of compliance.</p> <p>Detailed features of the fire-isolated stairways will be assessed with the requirements of AS1428.1 at the CC stage of works.</p> <div data-bbox="341 1106 777 1357" data-label="Diagram"> </div> <p>Note: For stairways with 90° to 180° turns at landings, in order for the handrails to comply with the consistent height requirement, the risers have to be offset at the mid-landings OR provided with a 300mm handrail extension, so that no vertical sections are created in the handrails. This applies to both non- fire-isolated and fire-isolated stairways.</p>

Requirement	Slip resistance requirements as per BCA BCA Table D2.14 has the following Slip –resistance requirements when tested in accordance with AS4586:																
	<table border="1"> <thead> <tr> <th rowspan="2">Application</th> <th colspan="2">Surface conditions</th> </tr> <tr> <th>Dry</th> <th>Wet</th> </tr> </thead> <tbody> <tr> <td>Ramp steeper than 1:14</td> <td>P4 or R11</td> <td>P5 or R12</td> </tr> <tr> <td>Ramp steeper than 1:20 but not steeper than 1:14</td> <td>P3 or R10</td> <td>P4 or R11</td> </tr> <tr> <td>Tread or landing surface</td> <td>P3 or R10</td> <td>P4 or R11</td> </tr> <tr> <td>Nosing or landing edge strip</td> <td>P3</td> <td>P4</td> </tr> </tbody> </table>	Application	Surface conditions		Dry	Wet	Ramp steeper than 1:14	P4 or R11	P5 or R12	Ramp steeper than 1:20 but not steeper than 1:14	P3 or R10	P4 or R11	Tread or landing surface	P3 or R10	P4 or R11	Nosing or landing edge strip	P3
Application	Surface conditions																
	Dry	Wet															
Ramp steeper than 1:14	P4 or R11	P5 or R12															
Ramp steeper than 1:20 but not steeper than 1:14	P3 or R10	P4 or R11															
Tread or landing surface	P3 or R10	P4 or R11															
Nosing or landing edge strip	P3	P4															
	<p>Slip resistance requirements as per AS4299 AS4299 has slip resistance requirements based on requirements of AS3661 (Slip resistance of pedestrian surfaces) for the following areas:</p> <ul style="list-style-type: none"> - Floor surfaces in sanitary facilities including all toilets and bathrooms (essential feature). - Floor surfaces in the kitchens and Laundries (essential feature). - Pathways / walkways within the site, within landscaped areas, balconies and other external paved areas (desirable feature for Class A or B developments). - AS3661.1-1993 is an old Australian standard which has been superseded with AS4586:2013 (Slip resistance classification of new pedestrian surface materials). <p>HB 197/ HB198 An introductory guide to the slip resistance of pedestrian surface materials provides guidelines for the selection of slip-resistant pedestrian surfaces</p>																
Compliance Comments	Capable of compliance. For Slip resistance of surfaces the builder is required to provide a Certificate stating that the Slip resistance of the surfaces comply with the above listed requirements when tested as per AS4586. Details to be provided at the CC stage of works.																
Requirement	Every Passenger lift is to comply with the requirements of BCA E3.6.																
Compliance Comments	This has been assessed further in the report in the Lifts section. Refer to Lifts section.																
Requirement	Passing spaces requirement It is a requirement to provide passing spaces in accessways complying with AS1428.1 at maximum 20 M intervals, where a direct line of sight is not available. Space required is 1800x2800mm (in the direction of travel). Chamfer of 400x400mm is permitted at corners.																
Compliance Comments	N/A There are no accessways over 20M lengths in the development where a direct line of sight is not available.																
Requirement	Turning spaces requirement It is a requirement to provide turning spaces in accessways complying with AS1428.1-2009 within 2M of the end of accessways where it is not possible to continue travelling and at every 20M intervals. CLEAR Space required is 1540mmx2070mm in the direction of travel (measured from skirting to skirting).																
Compliance Comments	Complies <ul style="list-style-type: none"> - Adequate turning spaces have been provided with minimum common use passageway widths being 1540mm clear or alternatively a space of 1540mm x 2070mm provided at or within 2M of the end of the passageway. - A space of 1540m x 2070mm is also required / provided in front of all passenger lift doors. Details to be verified at CC stage of works.																
Requirement	Carpet specifications Carpet if used in areas required to be accessible are to be provided with pile height or thickness not more than 11mm and carpet backing not more than 4mm bringing the total height to a maximum of 15mm.																
Compliance Comments	Capable of compliance if carpets are provided in the common use areas. Carpet selections generally take place at CC stage of works. Selection of carpets as specified above will lead to compliance. Details to be verified at CC stage of works.																

BCA Part D3.4 Exemption	
Requirement	Access is not required to be provided in the following areas: <ul style="list-style-type: none"> - Where access would be inappropriate because of the use of the area - Where area would pose a health and safety risk - Any path which exclusively provides access to an exempted area
Compliance Comments	For information only. Areas such as lift machine rooms, fire services room, commercial kitchens etc. in the development are exempted from providing access under this clause due to WHS concerns. Where a care taker is provided in the development, the toilet provided exclusively for use by the caretaker can be excluded from providing access based on the provisions in this clause.

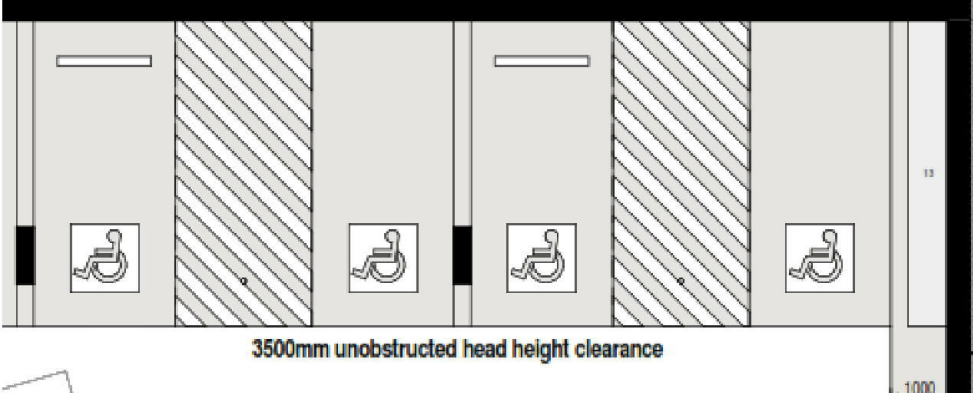
BCA Part D3.5 Accessible Carparking	
Requirement	Class 2 There are no Accessible carparking requirements for a Class 2 under the BCA. If adaptable housing has been mandated by the Council, then carparking spaces for Adaptable units will be required under the requirements of AS4299- Adaptable housing.
Compliance Comments	Complies Penrith Council requires provision of 10% Adaptable units in the development. Development has total number of 40 units. 10% of 40 = 4 required Adaptable units. Therefore, 4 accessible carparking spaces are required for the residential component of the development. 4 Accessible compliant car parking spaces have been provided in development. One accessible compliant parking space is required to be allocated to each of the Adaptable units. Basement 1  Detailed features of the accessible/ adaptable parking spaces are to be verified at CC stage of works.

	BCA Part D3.6 Signage
Requirement	Braille and Tactile signage is required to identify Accessible Sanitary facilities
Compliance Comments	N/A No common use sanitary facilities have been proposed in the development.
Requirement	Braille and Tactile signage is required to identify Ambulant Sanitary facilities
Compliance Comments	N/A No common use sanitary facilities have been proposed in the development.
Requirement	Braille and Tactile signage is required to identify Hearing Augmentation
Compliance Comments	N/A Hearing augmentation is not provided since there is no inbuilt amplification system proposed in the development.
Requirement	 <p>Braille and Tactile signage is required to identify a Fire exit door required by E4.5 by stating the 'Exit' and 'Level', followed by either:</p> <ul style="list-style-type: none"> - The floor level number or - Floor level descriptor or - A combination of both of the above. <p>Sign must be located on the side that faces a person seeking egress The "?" shown in image above is to be replaced with the floor level where the door is located. Image of the running person is optional.</p>
Compliance Comments	Capable of compliance. All doors nominated as Exit doors require signage as described above. Signage selections generally take place at CC stage of works. Selection of signage as specified above will lead to compliance. Details of selected signage to be verified at CC stage of works.
Requirement	Signage is required to a non-accessible pedestrian entrance
Compliance Comments	N/A The development has only 1 entry which has been designed to be accessible.
Requirement	Signage is required where a bank of sanitary facilities is not provided with an accessible unisex sanitary facility.
Compliance Comments	N/A
Requirement	All signage is required to be as per Specification D3.6 Braille and Tactile Signs This includes location of signage, specifications in regards to braille and tactile characters, luminance contrast and lighting.
Compliance Comments	Capable of compliance. Signage selections generally take place at CC stage of works. Selection of signage as specified above will lead to compliance. Details of selected signage to be verified at CC stage of works.
	BCA Part D3.8 Tactile indicators (TGSIs)
Requirement	<p>TGSIs are required when approaching:</p> <ul style="list-style-type: none"> - Stairways other than fire-isolated stairways. - Escalators / passenger conveyor / moving walk. - Ramp (other than fire-isolated ramps / kerb or step or swimming pool ramps). - Under an overhead obstruction of <2M if no barrier is provided. - When accessway meets a vehicular way adjacent to a pedestrian entry (if no kerb / kerb ramp provided at the location). <p>Compliance is required with AS1428.4.1 including Luminance contrast and slip resistance requirements for all TGSIs.</p>
Compliance Comments	Capable of compliance. TGSI selections generally take place at CC stage of works. Selection of TGSIs as specified will lead to compliance and these selection details are to be verified at CC stage of works.

	BCA Part D3.11 Limitations on Ramps
Requirement	On an accessway: <ul style="list-style-type: none"> - A series of connected ramps must not have a combined vertical rise of more than 3.6M; - And a landing for a step ramp must not overlap a landing for another step ramp or ramp.
Compliance Comments	N/A No ramps have been identified in the development.
	BCA Part D3.12 Glazing on Accessways
Requirement	Glazing requirements: Where there is no chair rail, handrail or transom, all frameless or fully glazed doors, sidelights and any glazing capable of being mistaken for a doorway or opening are required to have a glazing strip as per requirements of AS1428.1
Compliance Comments	Capable of compliance Glazing strips are required to be provided to full length glazed areas (doors and windows) used in common use areas such as lift lobbies and common passageways. Glazing strip selections generally take place at CC stage of works. Selection of glazing strips as specified above will lead to compliance and these selection details are to be verified at CC stage of works.
	BCA Part F Accessible Sanitary Facilities
	BCA F2.4 Accessible sanitary facilities
Requirement	Accessible unisex toilet is to be provided in accessible part of building such that; <ul style="list-style-type: none"> - It can be entered without crossing an area reserved for 1 sex only - Where male and female sanitary facilities are provided at different locations, Accessible unisex toilet is only required at one of the locations - Even distribution of LH and RH facilities - An accessible facility is not required on a level with no lift / ramp access.
Compliance Comments	N/A No common use sanitary facilities have been proposed in the development.
Requirement	Accessible unisex toilet are to be designed in accordance with AS1428.1-2009
Compliance Comments	N/A No common use sanitary facilities have been proposed in the development.
Requirement	Ambulant use male / female toilets are to be provided if an additional toilet to the Accessible unisex toilet is provided
Compliance Comments	N/A No common use sanitary facilities have been proposed in the development.
Requirement	Ambulant use toilets are to be designed in accordance with AS1428.1-2009
Compliance Comments	N/A No common use sanitary facilities have been proposed in the development.
	BCA F2.4(a) Accessible unisex sanitary compartments
Requirement	Class 2 <ul style="list-style-type: none"> - At least 1 unisex Accessible toilet when sanitary compartments are provided in common areas.
Compliance Comments	N/A No common use sanitary facilities have been identified in the development.
	BCA F2.4(b) Requirements for Accessible unisex showers
Requirement	Class 2 <ul style="list-style-type: none"> - At least 1 unisex Accessible shower when showers are provided in common areas.
Compliance Comments	N/A No common use shower facilities have been identified in the development.

BCA Part E Lift Installations	
BCA E3.2 Stretcher facility in lifts	
Requirement	A Stretcher lift is to be provided if a passenger lift is installed to serve any storey with an effective height of 12M. The space requirement is 600mm wide x 2000mm deep x 1400mm high above the floor level. Confirm this requirement with your BCA consultant.
Compliance Comments	Capable of compliance Details to be verified at CC stage of works.
BCA E3.6 Passenger lift	
Requirement	In an accessible building, Every Passenger Lift (excluding electric passenger lift, electrohydraulic passenger lift, inclined lift) must be subject to limitations on use and must comply with Tables E3.6a and E3.6b
Compliance Comments	Capable of compliance. A certificate of compliance from the lift supplier will be required at the CC stage of works stating that the proposed lift complies with the requirements of BCA Part E3- Lift installations.
Requirement	Limitations on use of Stairway platform lifts, Low-rise platform lift, Low-rise, low-speed constant pressure lift and small sized, low-speed automatic lift
Compliance Comments	N/A Not identified in the development.
Requirement	Handrail requirements for passenger lifts. Apart from stairway platform lift and low-rise lifts, a handrail is required as per AS1735.12.
Compliance Comments	Capable of compliance. Details to be verified at CC stage of works.
Requirement	Lift floor dimensions (excluding stairway platform lift) - Lifts traveling 12M or under, floor size, 1100mm wide x 1400mm deep - Lifts travelling more than 12M, floor size 1400mm wide x 1600mm deep
Compliance Comments	Capable of compliance Details to be verified at CC stage of works. Additional lift car size may apply if stretcher lift is required under the BCA.
Requirement	Minimum Door opening size complying with AS1735.12, not less than 900mm clear (excluding stairway platform lift).
Compliance Comments	Capable of compliance Details to be verified at CC stage of works.
Requirement	All lifts with a power operated door are required to have a Passenger protection system complying with AS1735.12.
Compliance Comments	Capable of compliance Details to be verified at CC stage of works.
Requirement	Lift landing doors to be provided at upper landing (excluding stairway platform lift).
Compliance Comments	Capable of compliance Details to be verified at CC stage of works.
Requirement	Lift car and landing control buttons to comply with AS1735.12 (excluding stairway platform lift and low-rise platform lift).
Compliance Comments	Capable of compliance Details to be verified at CC stage of works.
Requirement	Lighting (for all enclosed lift cars) to be provided in accordance with AS1735.12 and AS1680. Minimum illuminance of 100 lx is required at the level of the car floor and average of 50 lx is required on the control panel surface.
Compliance Comments	Capable of compliance Details to be verified at CC stage of works.

Requirement	To all lifts serving more than 2 levels , audible and visual indication to be provided as per AS1735.12.
Compliance Comments	Capable of compliance. Details to be verified at CC stage of works.
Requirement	Emergency hands free communication (excluding stairway platform lift) – provide a button that alerts a call centre and a light that the call has been received.
Compliance Comments	Capable of compliance Details to be verified at CC stage of works.

Additional Features required as per AS1428

Refer to AS1428 for full list of requirements.

	<p>The following accessibility requirements apply only to:</p> <ul style="list-style-type: none"> - Common use areas within the residential component (including passageways leading to SOUs)
Requirement	<p>Accessway width requirements</p> <ul style="list-style-type: none"> - All Accessway widths are to be a minimum of 1M clear (measured from skirting to skirting) with vertical clearance of at least 2M
Compliance Comments	<p>Complies. Details to be verified at CC stage of works.</p>
Requirement	<p>Doorway requirements</p> <ul style="list-style-type: none"> - All common use doorways in the development to be in accordance with AS1428.1 - Door thresholds are to be level or they can incorporate a Threshold ramp as per AS1428.1 i.e. max 1:8 grade, max height of 35mm and located within 20mm of door leaf. - Distance between successive doorways in airlocks to be 1450mm which is measured when the door is in open position in case of swinging doors.
Compliance Comments	<p>Capable of compliance. Details to be verified at CC stage of works.</p>
Requirement	<p>Door hardware requirements</p> <ul style="list-style-type: none"> - Door hardware including door handles, door closers and the in-use indicators / snibs in accessible and ambulant toilets are required to comply with requirements of AS1428.1.
Compliance Comments	<p>Capable of compliance. Door hardware selections generally take place at CC stage of works. Selection of door hardware as specified above will lead to compliance and these selection details are to be verified at CC stage of works.</p>
Requirement	<p>Luminance contrast requirements for doorways.</p> <ul style="list-style-type: none"> - All doorways to have a minimum luminance contrast of 30% provided as per AS1428.1 with the minimum width of the luminance contrast to be 50mm.
Compliance Comments	<p>Capable of compliance. Painting schedule is generally developed at the CC stage of works. The painting schedule of walls/doors and door frames are to consider the above requirements when colours are selected. Generally, a light colour door with a dark colour frame will satisfy requirements. Selection details are to be verified at CC stage of works.</p>
Requirement	<p>Floor or ground surfaces</p> <ul style="list-style-type: none"> - Use slip-resistant surfaces. The texture of the surface is to be traversable by people who use a wheelchair and those with an ambulant or sensory disability. - Abutment of surfaces is to have a smooth transition. Construction tolerances to be as per AS1428.1 - Grates if used in the accessible path of travel is required to comply with the requirements as per AS1428.1
Compliance Comments	<p>Capable of compliance. Floor surface selections generally take place at CC stage of works. Selection of floor surfaces as specified above will lead to compliance and these selection details are to be verified at CC stage of works.</p>
	<p>Switches, Controls and Lighting requirements</p> <ul style="list-style-type: none"> - All switches and controls (including controls for intercom facilities and external lift control buttons) on an accessible path of travel, Accessible SOUs and Accessible sanitary facilities to be located as per requirements of AS1428.1
Compliance Comments	<p>Capable of compliance. Lighting fixture selections and locations generally take place at CC stage of works. Selection of lighting fixtures and locating them as specified above will lead to compliance. These selection/location details are to be verified at CC stage of works.</p>

AS4299.1995- Adaptable Housing

Appendix A of AS4299 schedule is a list of features to be incorporated into a housing unit for it to be termed an 'Adaptable House'.

There are 3 Classification levels for Adaptable Housing

Adaptable Class A in which all 119 essential and all desirable features are to be incorporated.

Adaptable Class B in which all essential and 50% of 64 available desirable features are to be incorporated

Adaptable Class C in which all essential features are to be incorporated.

4 Adaptable units are required by the Council's DCP to a Class C level.
The units designated as adaptable are unit numbers **01, 02, 12, and 13**

At DA stage there is insufficient information to certify compliance with the Standard, however, in accordance with the table below, the nominated units can comply with the spatial requirements of AS4299 for Adaptable Housing.

Typical adaptable unit layout

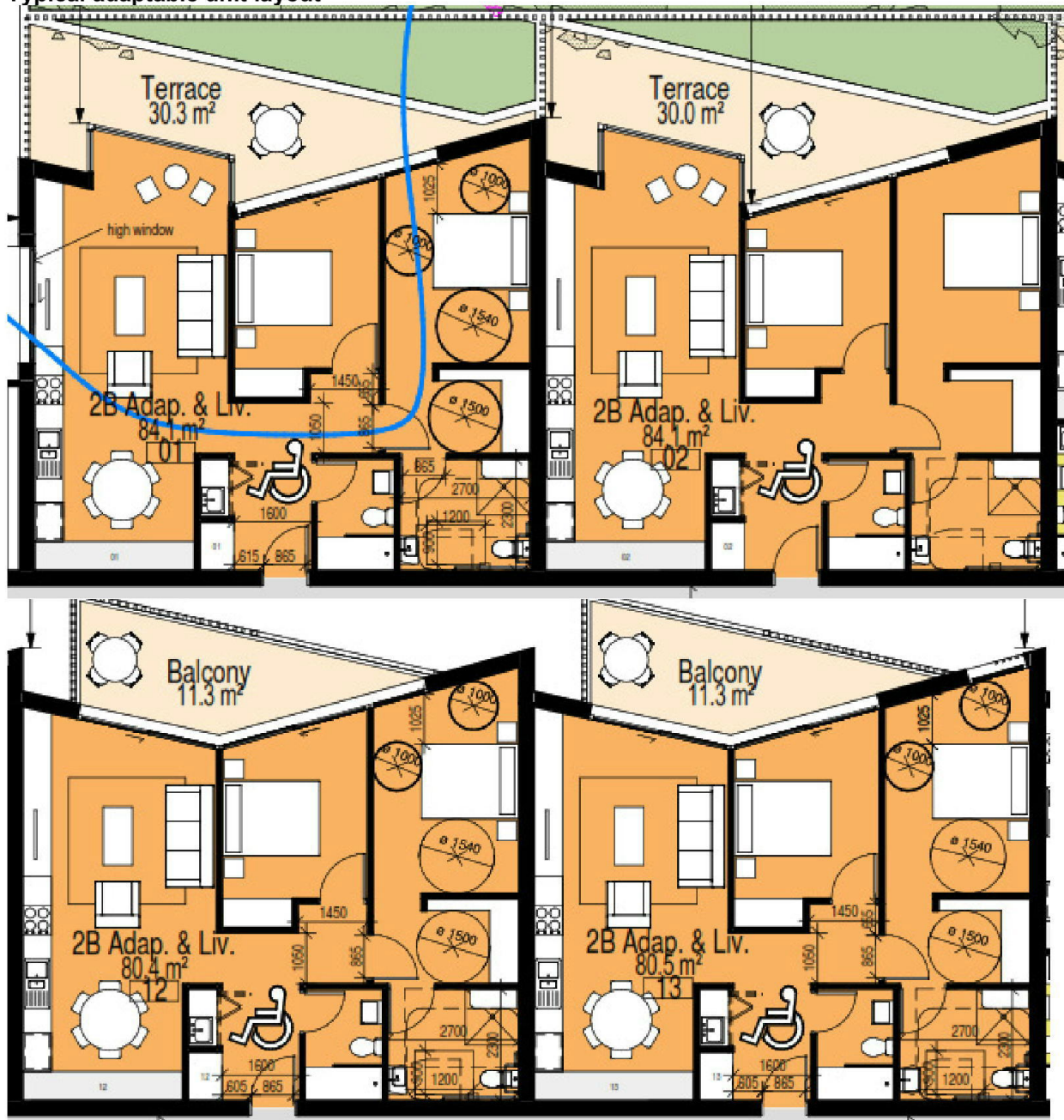

By incorporating the essential requirements listed Checklist below in the Specifications, the nominated Adaptable units can achieve full compliance with Adaptable House Class C

AS4299.1995 - Class C – Essential requirements.

R☑= Required;

C☑ =Capable of compliance at **by adding the requirement to the project specifications** or in some cases capable of compliance at post adaptation stage (where noted in comments).

Requirements as per AS4299	R	C	Comments
Siting An AS1428.1 compliant, continuous accessible path of travel is required from street frontage and vehicle parking to entry doorway of the Adaptable unit.	☑	☑	Complies. Access is provided from street by means of an AS1428.1 compliant ramp / walkway and from accessible parking space by means of a lift. Details to be verified at the CC stage
Letter boxes Letterboxes to be on hard standing area connected to accessible pathway	☑	☑	Capable of compliance. Details to be verified at the CC stage
Parking Car parking space or garage of minimum 6.0Mx 3.8M or a hard surfaced level outside of 5.4Mx3.8M is to be provided as a sheltered car park or can be provided in the future	☑	☑	Complies. Space can also be provided as per AS2890.6 Details to be verified at the CC stage

Accessible Entry

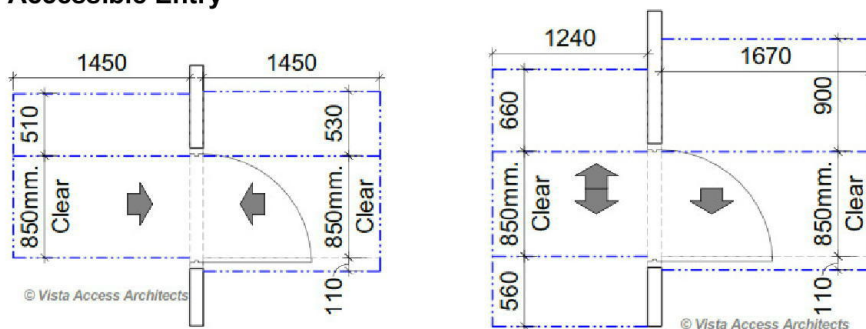

Door circulation requirements of AS1428.1 with approach directions shown with arrows below. Accessible entry to be provided with, - An accessible door threshold - 1550mm diameter landing - 850mm clear opening door with clearances, door hardware operable with one hand and located 900-1100mm above floor	☑	☑	Capable of compliance. Details to be verified at the CC stage
Interior: General - Internal doors to have 820mm minimum clearance with provision for compliance with AS1428.1 for door approaches and minimum corridors width of 1M - Door hardware operable with one hand and located 900-1100mm above floor	☑	☑	Capable of compliance. Provide an 850mm clear opening door to the adaptable bathroom and 1 main bedroom. Rest to have 820mm clear opening. Details to be verified at the CC stage
Living room and dining room Circulation space of minimum 2250mm diameter.	☑	☑	Complies.
Kitchen It is general industry practice to accept that kitchen is something that has a very short life span and can be completely replaced when required to be adapted. As such only the following requirements apply, <u>Potential of achieving the following at Post- Adaptation:</u> - Minimum width 2.7M and 1550mm clear between benches - Provision for circulation at doors to comply with AS1428.1 (if doors provided)	☑	☑	Can be compliant post adaptation. Details to be verified at the CC stage

- Provision for benches, taps, cooktops, ovens as required under AS4299			
---	--	--	--

Main bedroom

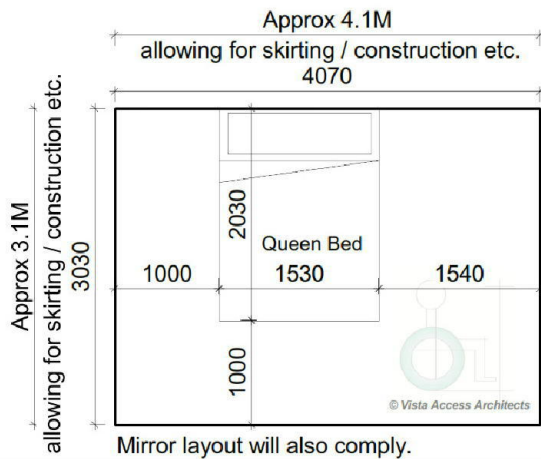

Mirror layout will also comply.

At least one bedroom of area sufficient to accommodate a queen size bed and wardrobe and circulation space requirements of AS1428.2	<input checked="" type="checkbox"/>	<input checked="" type="checkbox"/>	Complies Details to be verified at the CC stage
---	-------------------------------------	-------------------------------------	--

Main Adaptable bathroom

Post Adaptation bathroom layout shown

Noted dimensions in these diagrams are approximate and depend on selected features such as size of the basin. These dimensions include allowances for reinforcements and normal construction tolerances.

Thick blue line indicates the location of wall reinforcements which are to be provided at pre-adaptation itself. Red dotted line indicates the shower circulation space. Black dotted line indicates the WC pan circulation space.

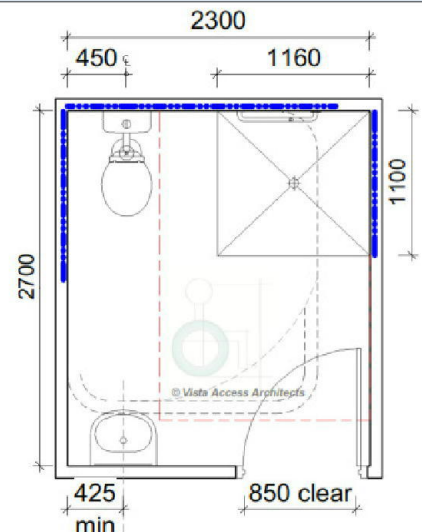

<ul style="list-style-type: none"> - Provision for bathroom area with Circulation spaces of Shower and WC (including fixtures) to comply with AS1428.1. - Note that wall reinforcements and waterproofing details to comply with AS4299 	<input checked="" type="checkbox"/>	<input checked="" type="checkbox"/>	Complies A bathroom with minimum space of 2Mx 2.95M or 2.3Mx2.7M or 2.4Mx2.45M is achievable. Wall reinforcement details to be verified at the CC stage.
---	-------------------------------------	-------------------------------------	--

Wall reinforcement requirements at Pre-adaptation

Reinforcement requirements for the Adaptable unit for WC and shower (in post-adaptive position) showed hatched. Refer to AS4299 for further details.



Laundry			
<ul style="list-style-type: none"> - Provision for adequate circulation space in front of or besides appliances (minimum 1550mm depth) - Circulation at doors to comply with AS1428.1 - Provision for automatic washing machine - 	<input checked="" type="checkbox"/>	<input checked="" type="checkbox"/>	Capable of compliance. Details to be verified at the CC stage

Other General requirements				
<ul style="list-style-type: none"> - All surfaces to be Slip resistant to AS3661 and AS 4586 - All GPOs and Lighting/ lux requirements as per AS4299 - All waterproofing as per AS4730 		☑	☑	Capable of compliance. Details to be verified at the CC stage
Requirement	<ul style="list-style-type: none"> - Where the location of fixtures such as WC pans, wash basins, sinks, laundry fixtures and any other fixtures are to be relocated post-adaptation to comply with AS1428.1, then the service pipes (waste and water supply pipes) have to be laid in the correct AS1428.1 specified position at pre-adaptation itself and the services to be capped off for future use. 			
General recommendations (Advisory only / not mandatory)	<ul style="list-style-type: none"> - It is recommended that where balconies / outdoor areas have been provided to Adaptable units, provide the sliding doors such that the floor tracks are recessed, so level access can be provided to the balcony / outdoor areas from inside the unit. - Sliding doors in the living areas leading to outdoor areas are to be such that opening of the door is able to provide a clear opening space of 850mm with a latch side space of 530mm. - If the balcony is to be brought up to the same level as the unit at post-adaptation by means of decking etc. then ensure that the minimum handrail height requirements required under the BCA are complied with, considering the raised height of the balcony. - Consideration to be given to recess the slab in the wet areas so that there is no level difference once the floor finishes are applied (i.e. flush transition from carpeted area to tiles area). 			

SEPP 65 – Part 4Q1

Compliance assessment with Objective 4Q1 that requires 20% of the units to incorporate the features of the **Livable Housing Guidelines Silver level**.

Total number of residential units in the development = 20% of 40 = 8 = **8** required Livable units.

Since 4 of the units (**01, 02, 12 and 13**) already comply with the Adaptable unit requirements, these units are also capable of satisfying the intent of Silver level of Livable Housing Guidelines as noted in the table below.

In addition to the adaptable units provided the following 4 units **18, 28, 38 and 53** are capable of providing compliance with the features of Silver level of Livable Housing Guidelines as noted in the table below.

Unit 53

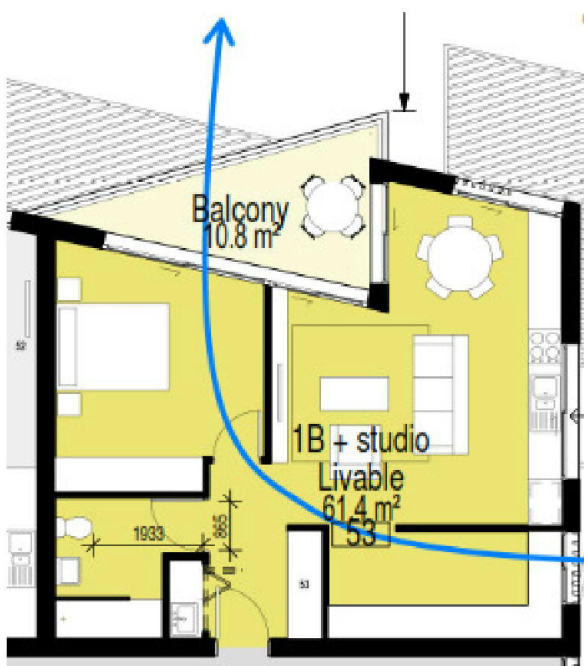

Typical Units 18, 28 and 38

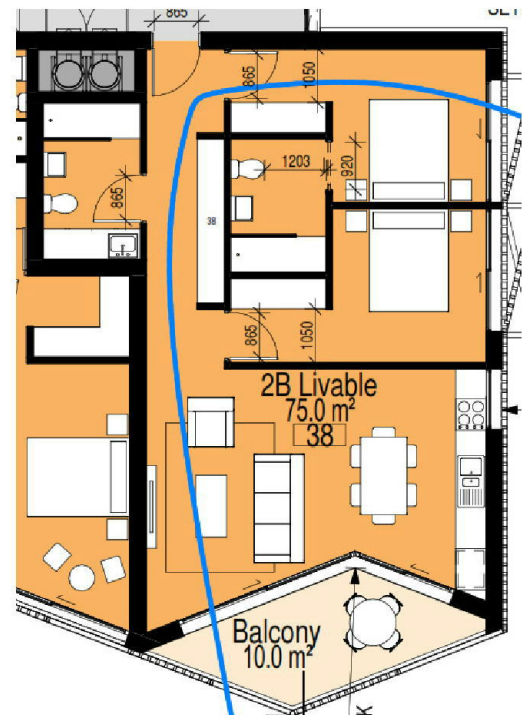

By incorporating the requirements of the below Checklist in the Specifications of the project, the nominated Livable units can achieve full compliance with Livable Housing Guidelines- Silver Level

Note that in this case the adaptable units are also be counted as Livable / LHA Silver level unit in which case the below requirements apply in addition to the AS4299 requirements.

Design Element	Requirements (All dimensions noted are required to be clear of finishes as required under AS1428.1)	Compliance / Comments
1 Dwelling Access	(a) Provide a safe and continuous 1M clear width pathway from front site boundary to an entry door to the dwelling.	Complies. Verify at CC
	(b) Path including any ramps and walkways to have no steps, even firm, slip-resistant surface, max 1:40 crossfall, max slope of 1:14 with landings of 1.2M every 9M and landings every 15M for 1:20 walkways. 1.2M clear width of ramps are required.	
	(c) Pathway may be provided via an associated car parking in which case the car parking space to be - 3200 (width) x5400 (length), - even, firm and slip resistant, level surface of 1:40 max grade and 1:33 max grade for bitumen	N/A Access is provided from the site boundary.
	(d) Step ramp may be provided at an entrance doorway. The step ramp to be max 190mm height, max 1:10 grade, max 1900mm length.	N/A

	(e) Level landings of 1200mm are required exclusive of the swing of the door or gate and to be provided at the head and foot of the ramp.	N/A
2 Dwelling entry	(a) Dwelling Entry should provide an entrance door with <ul style="list-style-type: none"> (i) min clear opening width of door to be 820mm (ii) Step free threshold of max 5mm with rounded or bevelled lip (iii) reasonable shelter from the weather 	Capable of compliance. Verify at CC
	(b) Level landing of 1200x1200mm at step-free entrance door on the arrival / external side of the entrance door.	Complies Verify at CC
	(c) Max permissible threshold is less than 56mm where provided with a 1:8 grade threshold ramp.	N/A
	(d) Entrance to be connected to a pathway (specified under Element 1) Note: The entrance to incorporate waterproofing and termite management requirements as specified in the NCC	Complies
3 Internal doors and corridors	(a) Doors to rooms on the entry level used for living, dining, bedroom, bathroom, kitchen, laundry and sanitary compartments to be <ul style="list-style-type: none"> (i) 820mm clear opening and (ii) provided with a level threshold of max 5mm between abutting surfaces with rounded or bevelled lip 	Capable of compliance. Verify at CC
	(b) Internal corridors and passageways to doorway to be min 1M clear (measured from skirting to skirting)	Capable of compliance. Verify at CC
4 Toilet	(a) One Toilet to be provided on the ground or entry level that provides, <ul style="list-style-type: none"> (i) Min 900mm between walls or amenities (ii) Min 1200mm clear space in forward of the WC pan exclusive of door swing. (iii) The toilet pan to be positioned in the corner of a room to enable handrails 	Complies. Verify at CC
5 Shower	(a) One bathroom should feature a slip resistant, hobless shower recess. Shower screens are permitted provided they can be easily removed at a later date.	Capable of compliance. Verify at CC
	(b) The shower recess should be located in the corner of the room to enable the installation of grabrails at a future date.	
	For hobless specification please see Australian Standard AS3740-3.6. Reinforcement guidelines for walls in bathrooms and toilets are found in element 6	
6 Reinforcement of bathroom & toilet walls	(a) Except for walls constructed of solid masonry or concrete, the walls around the shower, bath (if provided) and toilet should be reinforced to provide a fixing surface for the safe installation of grabrails.	Capable of compliance. Verify at CC
	(b), (c) and (d) the walls around toilet, bath and shower to be via: <ul style="list-style-type: none"> (i) Noggins with a thickness of at least 25mm (ii) Sheeting with a thickness of at least 12mm Refer to diagrams provided in the Livable Housing Guideline document.	Capable of compliance. Verify at CC

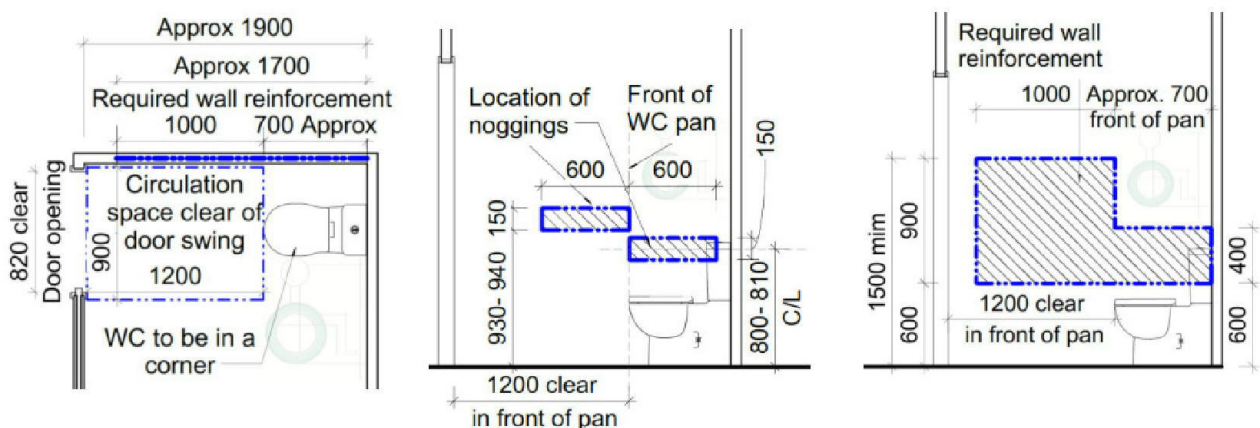

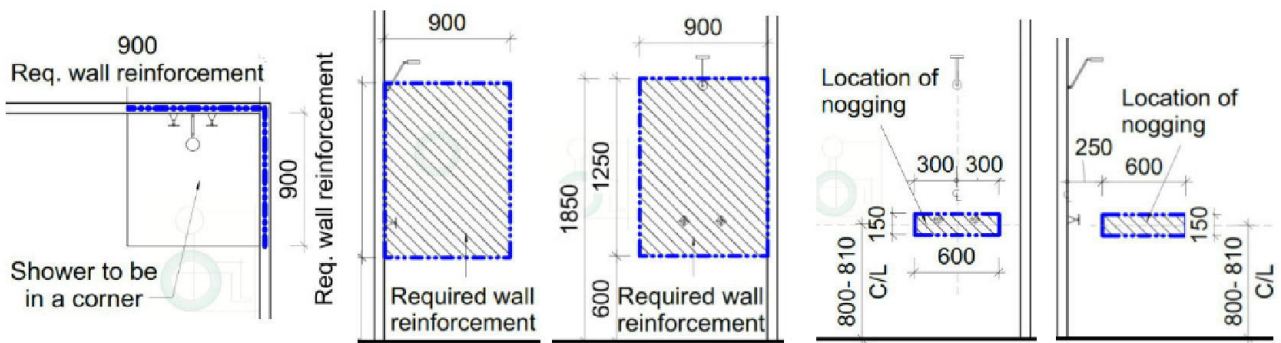

7
Internal Stairways

Stairways in dwellings must feature:
(i) a continuous handrail on one side of the stairway where there is a rise of more than 1m. a minimum clear width of 1000mm

N/A
No internal stairway in units.

Disability Discrimination Act

Advisory Only

The Federal Disability Discrimination Act 1992 (DDA) provides protection for everyone in Australia against discrimination based on disability. Section 32 of the DDA focuses on the provision of equitable and dignified access to services and facilities for people with mobility, sensory and cognitive disabilities.

Disability discrimination happens when people with a disability and their relatives, friends, carers, co-workers or associates are treated less fairly than people without a disability.

Compliance with Access to Premises Standards give certainty to building certifiers, building developers and building managers that, if access to (new parts) of buildings is provided in accordance with these Standards, the provision of that access, to the extent covered by these Standards, will not be unlawful under the DDA. This however applies only to the new building or new parts of an existing building and its affected part. All areas outside the scope of these areas are still subject to the DDA. We cannot guarantee or certify for DDA compliance because DDA compliance can only be assessed by the Courts.

Scope of DDA extends beyond the building fabric and also includes furniture and fittings.

Some recommendations to address common furniture and fittings have been listed below. Non-provision of the below recommendations may not affect compliance under the BCA but may leave the building owner vulnerable to a claim under the DDA.

For new kitchens / BBQ areas in residential common use areas, it is suggested that this kitchen could be made partially accessible by providing a width of 900mm next to the sink as vacant space (without cabinetry under the bench top) and a long lever tap with spout and handle within 300mm from the front of the benchtop. The distance in between the benches to be 1550mm. 1 double GPO to be provided within 300mm from the edge of the benchtop. This would allow a person in a wheelchair to independently move within the kitchen and use basic facility, being the sink independently.

Statement of Experience

Farah Madon- Director

ACAA Accredited Access Consultant, Livable Housing & Changing Places Registered Assessor

- Accredited member of Association of Consultants in Access Australia (ACAA) Membership no 281
- Architect, registered with the NSW Architects Registration Board. Registration number 6940
- Member of Australian Institute of Architects (RAIA), A+ Practice member, 49397
- Registered Assessor of Livable Housing Australia. License no 10032
- Registered Assessor of Changing Places Australia. Registration no CP006

Farah's Educational Profile and Qualifications include:

- Bachelor of Architecture Degree with Honours (B.Arch.)
- OHS Construction Induction Training Certificate
- Units PRDAC401A/403A/503A & CPP40811 from Certificate IV in Access Consulting
- Unit CPP50711 from the Diploma in Access Consulting
- Successful completion of ACAA's Access Consultant's testing process
- Changing Places Australia Training Course

Farah has 20 years of experience of working in the field of Architecture and Access. Farah specialises in access consultancy services, including design for access, access related advise and auditing services and performance solution assessment for access related issues under the BCA by means of Expert Judgement. Farah has been invited as an expert witness for Access related matters in the Land and Environment Court.

Farah currently participates on the following key committees concerning access for people with disabilities, on an honorary basis:

- Vice President of Association of Consultants in Access Australia
- Convener of the ACAA's Access related Practice and Advisory Notes
- Community Representative Member of the Penrith City Council's Access Committee
- Member of Australian Institute of Architect's (RAIA) National Access Work Group (NAWG)
- Management Committee member of NSW Network of Access Consultants
- Livable Housing Australia's Industry Reference Group (IRG) Member
- Committee member of ME-064 Committee of Standards Australia responsible for the AS4299 and AS1428 suite of standards.

Meet our team

Vanessa Griffin- Access Consultant

ACAA Accredited Access Consultant & Livable Housing Assessor

- Accredited member of Association of Consultants in Access Australia (ACAA) Membership no 500
 - Member of AIBS – Australian Institute of Building Surveyors
- Vanessa's Educational Profile and Qualifications include:
- Diploma of Surveying and Diploma of Health and Building Surveying
 - Certificate IV in Access Consulting

Jenny Desai- Access Consultant

ACAA Associate Access Consultant

- Associate member of Association of Consultants in Access Australia (ACAA) Membership no 572

Jenny's Educational Profile and Qualifications include:

- Master of Design (M.Des) from University of Technology, Sydney
- Certificate IV in Access Consulting

