





**LEGEND**

-  **New Turf**  
Excavate / grade all areas to be turfed to 120mm below required finished levels. Do not excavate within 1500mm of the trunk of any existing tree to be retained. Ensure that all surface water runoff is directed towards the inlet pits, kerbs etc., and away from buildings. Ensure that no pooling or ponding will occur. Further rip the subgrade to 150mm. Install 100mm depth of imported turf underlay. Just prior to spreading the turf, spread 'Shirley's No.17 lawn fertilizer' over the underlay at the recommended rate. Lay 'Sir Walter Buffalo' turf rolls closely butted. Fill any small gaps with topsoil. Water thoroughly.
  -  **Brick garden edging (refer to detail)**  
Lay a single course of paving bricks in a mortar haunch (200mm wide and 100mm deep). The edges are to be laid in even curves and straight lines as shown on the plan. Edge is to finish flush with the adjacent turf and garden levels.
  -  **Existing trees or shrubs to be removed (pending Council approval)**
  -  **Existing post and rail boundary fencing to be retained or replaced (where required)**
  -  **Landscaped areas**  
Excavate all Planting Areas to a depth of 150mm below finished levels. Cultivate subgrade a further 150mm. Supply & install 100mm of soil mix that consists of 50% Site Top Soil (if suitable) with 50% ANL Organic Garden mix (or equivalent). Install 75mm depth of selected mulch.
- Note:**  
Maintenance:  
All landscape works are to be maintained for a period of twelve months from the date of practical completion. This includes all watering, weeding, spraying and re-mulching necessary to achieve vigorous growth. Any defects which arise during this period are to be rectified immediately. Any plants or areas of turf which fail during this period are to be replaced at no additional cost.
- Irrigation:**  
All garden areas on the landscape plan are to be covered by a fully automatic drip irrigation system. The controller is to be equal to a 'Richdel 446 PR' and is to be housed in a control box adjacent to the electricity meter. All pipework is to be PVC to satisfy AS 1477. All installation is to satisfy the Sydney Water Code and AS 3500. The system is to be installed by a suitable licensed contractor. All equipment and workmanship is to be guaranteed for a minimum period of 12 months.

**PLANT SCHEDULE**

Code	Latin Name [Common Name - Mature Height]	Qty	Size	Stake
<b>Trees</b>				
T	Tristanopsis laurina 'DQW10' 'Luscious® PBR' (Water Gum - 7m)	2	75 litre	yes
M	Magnolia grandiflora 'Little Gem' (Dwarf White Myrtle - 3m)	1	75 litre	yes
Jm	Jacaranda mimosifolia (Jacaranda - 8m)	6	75 litre	yes
Pyr	Pyrus ussuriensis (Manchurian pear - 8m)	8	75 litre	yes
<b>Shrubs</b>				
Ad	Austromyrtus dulcis (Midgen Berry - 1.5m)	16	200mm	-
Bx	Buxus microphylla japonica (box - 1m)	48	200mm	-
Cs	Camellia sasanqua (Camellia - 2m)	4	200mm	-
Cc	Callistemon citrinus (Crimson Bottlebrush - 2m)	12	200mm	-
De	Dorothy's excelsa (Gymea Lily - 1m)	7	300mm	-
Ka	Kunzea ambigua (Tick bush - 3m)	17	200mm	-
Lap	Lepidospermum flavescens (tea tree - 4m)	71	200mm	-
Mp	Muraya paniculata (cosmetic bark tree - 3m)	21	200mm	-
Sab	Syzygium australe (Dwarf Lilly Pilly - 3m)	13	200mm	-
Ve	Viburnum Emerald Lustre (Viburnum - 3m)	64	200mm	-
Wf	Westringia fruticosa (Coastal Rosemary - 1.5m)	23	200mm	-
Xr	Xanthorrhoea resinosa (Grass tree - 1m)	6	300mm	-
<b>Groundcovers</b>				
Fg	Festuca glauca (Blue fescue grass - 0.3m)	66	150mm pot	
Gg	Grevillea gausi chaudii (n/a - 0.3m)	18	150mm pot	
U	Lomandra longifolia (Spiny Mat Rush - 1m)	78	150mm pot	
Tj	Trachelospermum jasminoides (Star Jasmine - 0.3m)	55	150mm pot	

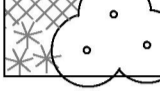
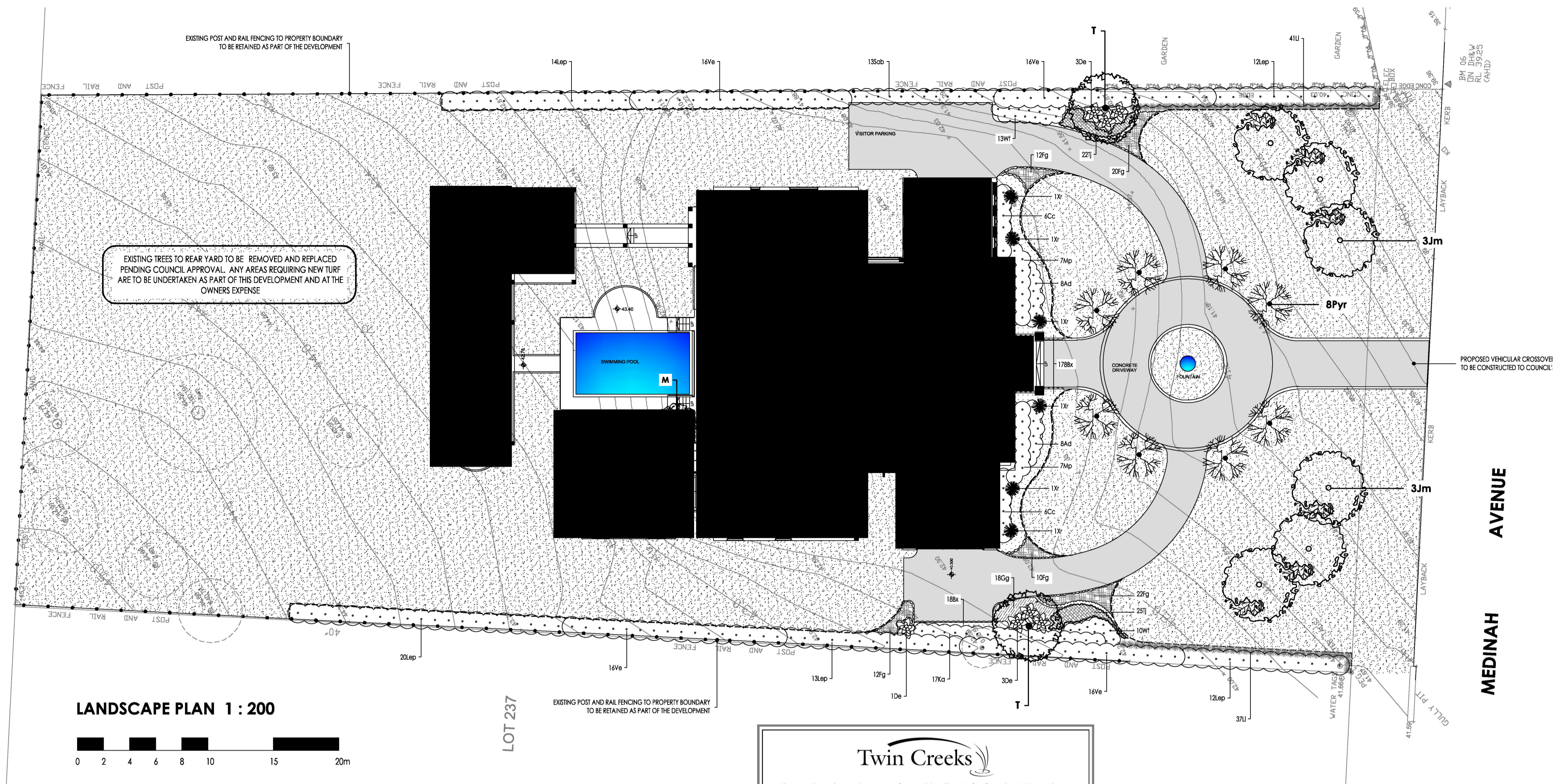

**LANDSCAPE PLAN 1 : 200**

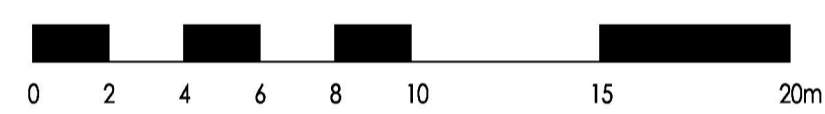

**Twin Creeks**

These plans have been reviewed by the Twin Creeks DRP and are considered in accordance with the Twin Creeks Pattern Book.

A stamped copy of these plans must be included with your DA to Penrith City Council prior to commencing construction.

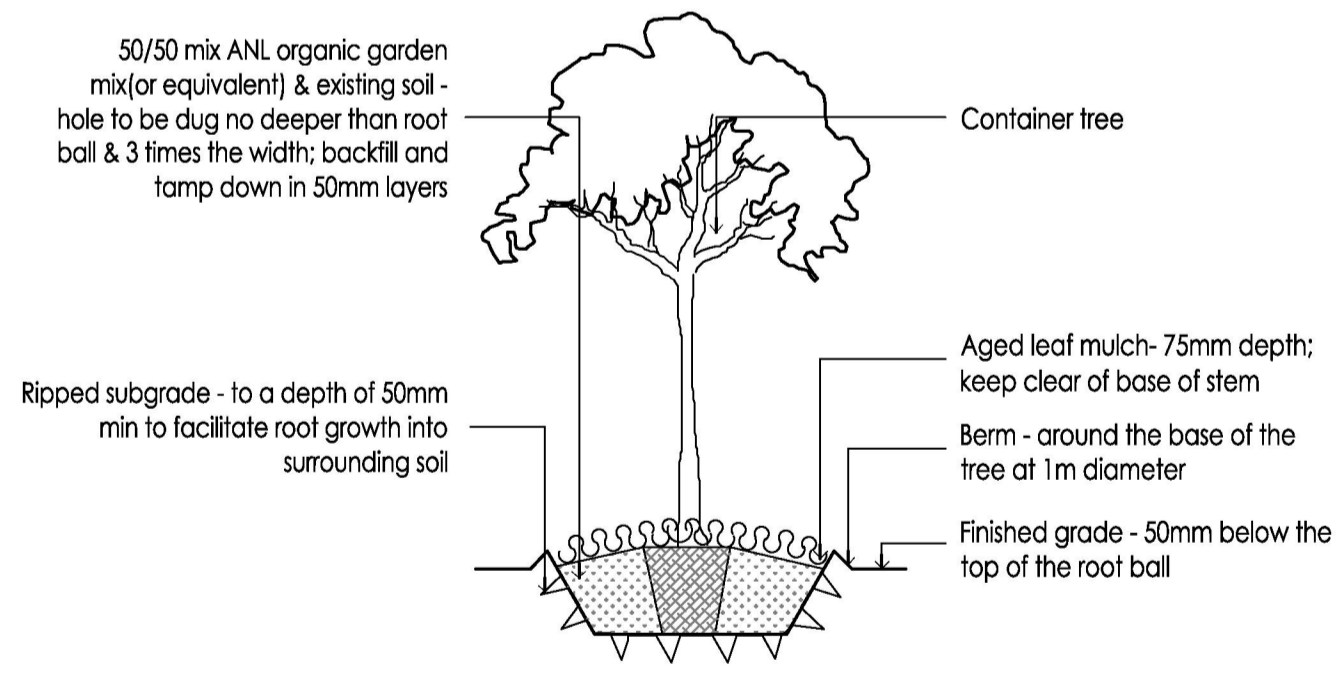
**1 Tree Planting Detail Section**  
NTS @ A1 (Not to Scale)

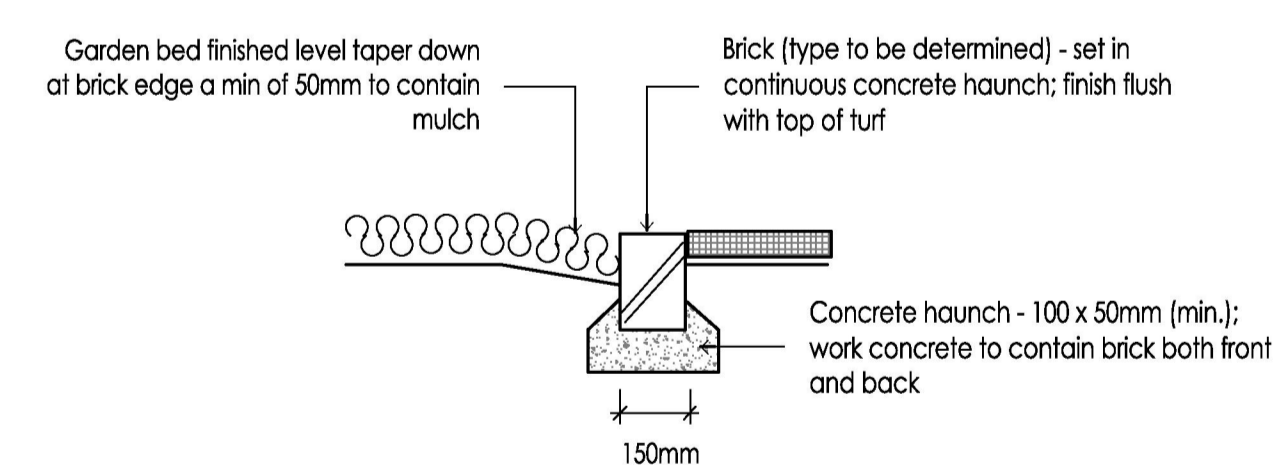

**2 Brick Edge Detail Section**  
NTS @ A1 (Not to Scale)

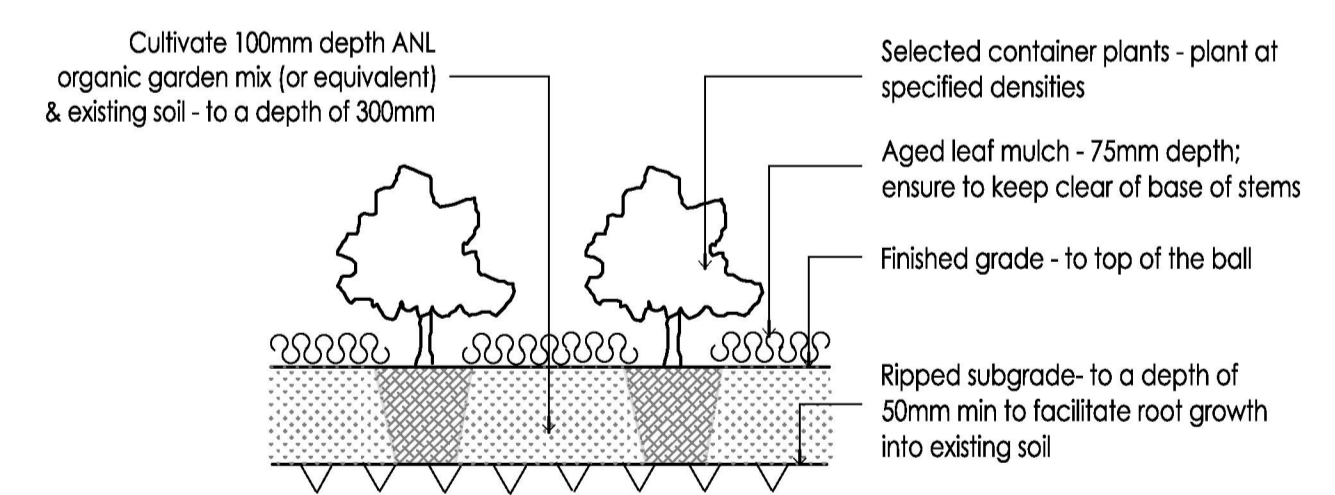

**3 Garden Bed Planting Detail Section**  
NTS @ A1 (Not to Scale)

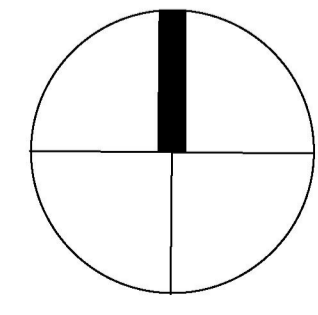
 <p><b>TGS</b> Landscape Architects</p> <p>Postal Address: PO BOX 457 BEECROFT NSW 2119</p> <p>ph. (02) 9980 1010 fax. (02) 9484 8071</p> <p>web. www.tgslandscape.com.au</p>	<p>Amendments</p> <table border="1" style="width: 100%; border-collapse: collapse;"> <tr> <td style="width: 20%;">02/05/2020</td> <td>Landscape DA Issue</td> </tr> <tr> <td> </td> <td> </td> </tr> <tr> <td> </td> <td> </td> </tr> <tr> <td> </td> <td> </td> </tr> </table>	02/05/2020	Landscape DA Issue							<p>Title: <b>LANDSCAPE PLAN</b></p> <p>Date: 2nd May, 2020</p> <p>Client: Mr &amp; Mrs I. Sadiddin</p> <p>Drawing number: 2020.0502DA1</p>	<p>Project: <b>PROPOSED NEW RESIDENCE</b></p> <p>North:</p> 
	02/05/2020	Landscape DA Issue									
<p>Design by: JB</p>	<p>Checked by: JB</p>	<p>Scale: 1 : 200@A1/1:400@A3</p>	<p>Issue: A</p>								
<p>22 Medinah Avenue <b>LUDDENHAM</b></p>											
<p>SHEET 1 of 1</p>											