



SOIL & WATER MANAGEMENT PLAN

1. Construction Zone

It is considered that the development can be constructed without the creation of a Construction Zone along the road frontage of the site. The following construction Program gives details of the management of the site during the construction period.

2. Construction Program

(i) *Methods of access and degrees for construction vehicles*

Construction vehicles will enter and leave the site over an all weather surface consisting of coarse crushed stone or blue metal constructed within the front setback area opposite the existing footpath crossing.

Excavation machinery is to be unloaded and loaded upon this all weather surface. Concrete pumps and trucks will also utilise the all weather surface for their operations.

(ii) *The proposed method of loading and unloading of materials on the site*

Materials will be unloaded upon the all weather surface within the front setback by means of cranes and mounted on the back of delivery trucks or unloaded by hand. It is not envisaged that a mobile crane will be required during the construction process.

(iii) *Areas within the site to be used for storage of excavated material, construction material and waste containers*

Equal amounts of cut and fill are proposed during excavation therefore little excavated material is required to be removed from the site. Some stockpiling of topsoil removed from the building area may be stored during construction in the rear yard area of the development.

Construction material will be stored wholly on the site before use and not on the footpath reserve.

A number of Colex waste bins will also be used for waste material. These will be located close to the building within the front setback and regularly collected.

(iv) *Methods of preventing excavated material being deposited on the road reserve*

Vehicles leaving the site will do so via the all weather surface and shakedown pit made of coarse crushed rock. Therefore any losses material will be left within the shakedown area and not deposited on the road reserve.

(v) *Method of support for excavation*

Any excavated area requiring support will be taken by the owner using treated pine retaining structures. Typical detail of retaining walls is attached.

(vi) *Location of shakedown pit*

3. Temporary Stormwater Disposal

All site stormwater during construction shall be disposed of according to the EPA's Management of Urban Stormwater for Construction Activities (refer to the Site Plan).

4. Sediment Control

Geotextile fabric shall be placed on the inside of site fencing to prevent sediment washing from the site into council's stormwater system.

5. Erosion / Dust Control

Where there is the potential of site erosion to produce excessive sediment runoff, suitable geotextile and haybale barriers shall be placed to alleviate the risk accordingly. Bare surfaces shall be kept moist in the event that council dust level regulations may be exceeded. Geotextile fabric located on the inside of fences shall also be utilised for dust control where necessary.

6. Stockpile Control

Stockpile areas shall be allocated within the site in advance to avoid stockpiling of materials on pavement, verge and road surfaces.

7. Rubbish Disposal

All rubbish shall be contained in the trade waste area nominated on Site Plan. Public property will be kept free of rubbish at all times.

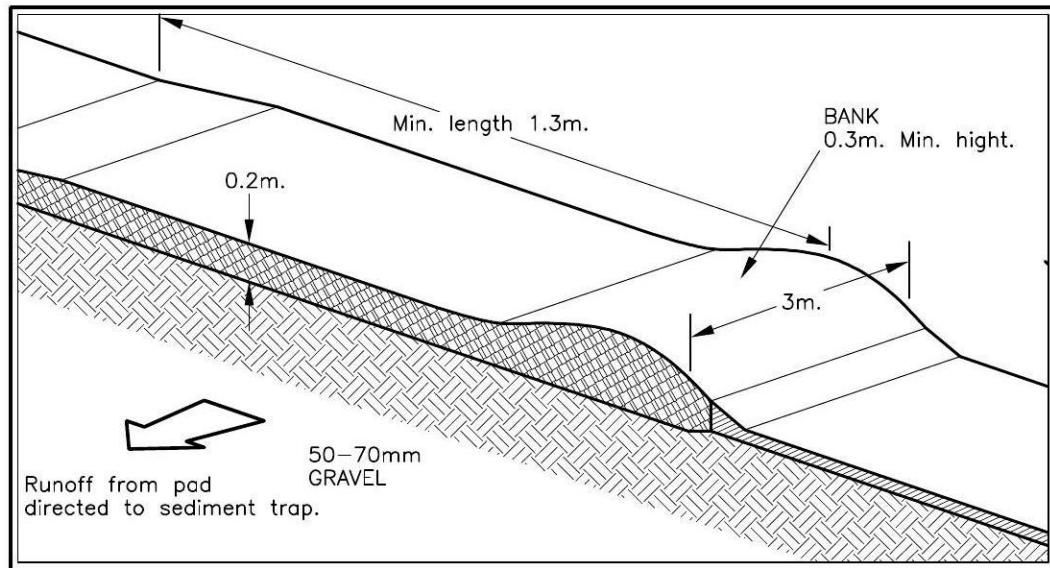

TEMPORARY CONSTRUCTION EXIT

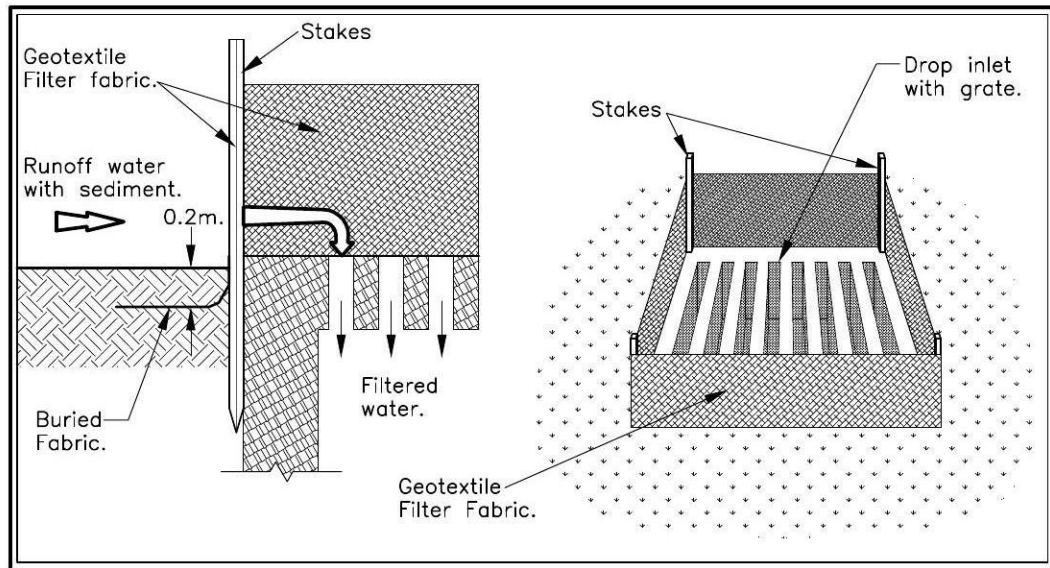

GEOTEXTILE FILTER FABRIC DROP INLET SEDIMENT TRAP

TEMPORARY STORMWATER DISPOSAL
 All site stormwater during construction shall be disposed of according to the EPA's Management of Urban Stormwater for Construction Activities (refer to the Site plan).

SEDIMENT CONTROL
 Geotextile fabric shall be placed on the boundary of the site to prevent sediment washing from the site into council's stormwater system.

EROSION/DUST CONTROL
 Where there is the potential of the site erosion to produce excessive sediment runoff, suitable geotextile and haybale barriers shall be placed to alleviate the risk accordingly. Bare surfaces shall be kept moist in the event that council dust level regulations may be exceeded. Geotextile fabric located on the inside of fences shall also be utilised for dust control where necessary.

STOCKPILE CONTROL
 Stockpile areas shall allocated within the site in advances to avoid stockpiling of materials on pavement, verge and road surfaces.

RUBBISH DISPOSAL
 All rubbish shall be contained in the trade waste area nominated on site plan. Public property will be kept free of rubbish at all times.

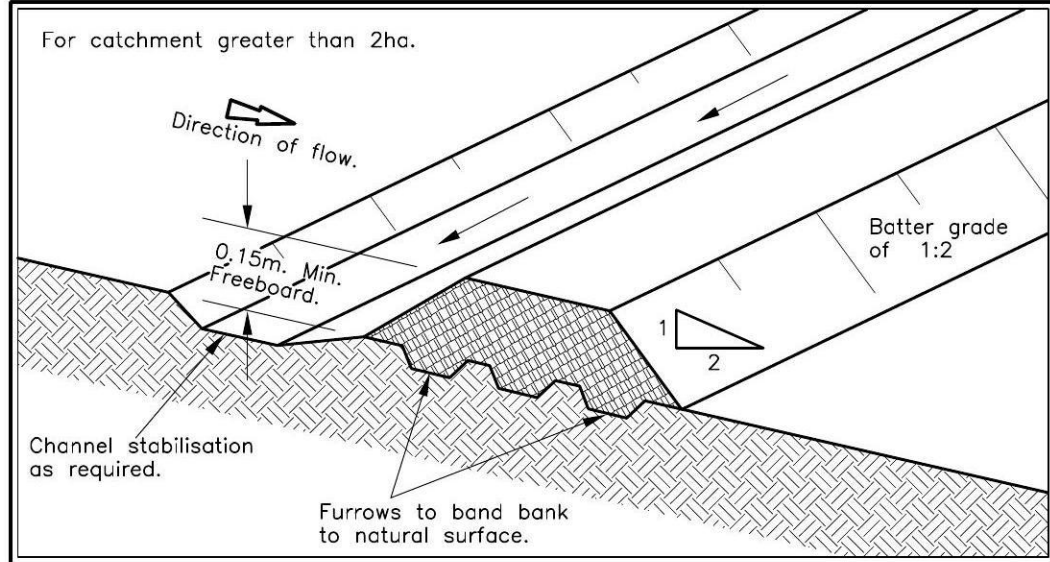

DIVERSION BANK AND CHANNEL

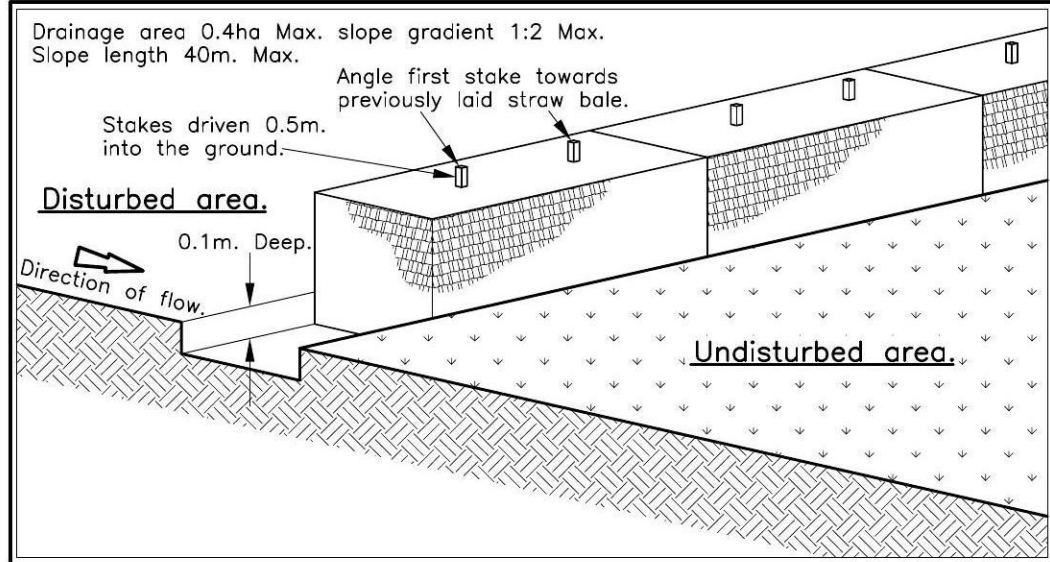

STRAW BALE SEDIMENT FILTER

ADOPTED SITE ENVIRONMENTAL MANAGEMENT PLAN
 The applicant, owner, builder, subcontractors, consultants and all others involved in the construction of the proposed residence are to be made fully aware of adopted site Environmental Management Plan applying to the land, referred to in the Section 88B instrument, and are to comply in all regards with the plan. A copy of the plan is to be retained on site for reference as required. This provision applies to all works associated with the construction of the dwelling, including landscaping works.

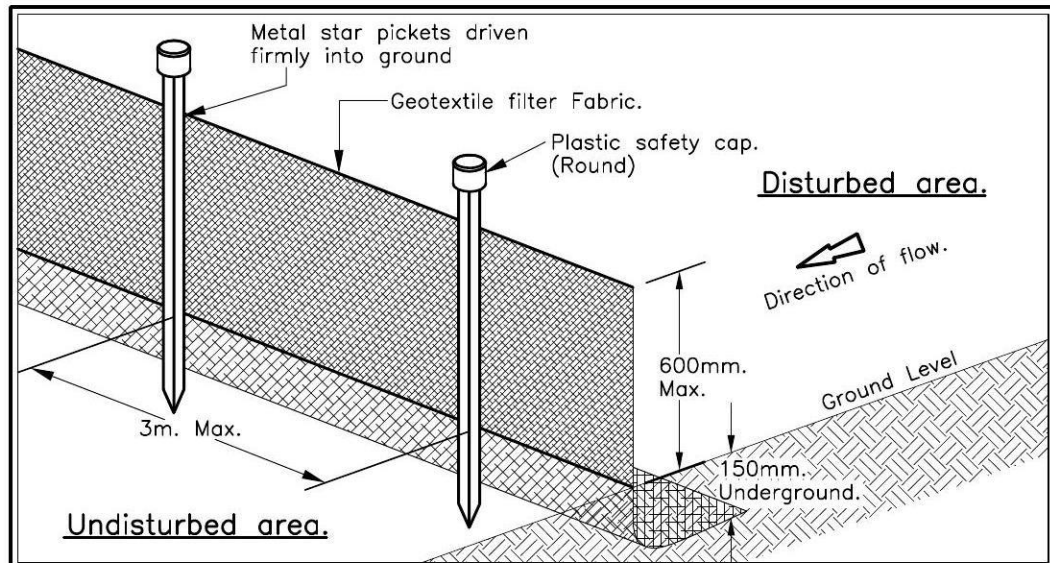

SEDIMENT FENCE

SOIL & WATER MANAGEMENT PLAN

MASTERTON HOMES PTY/LTD
 76 HEATHCOTE ROAD
 MOOREBANK NSW 2170
 PHONE: HEAD OFFICE 02 9601 4066
 SALES CENTRE 1300 4HOMES
 Lic. No.: 35558C
 ABN. 52 002 873 047
 www.masterton.com.au

Do not scale drawings use figured dimensions only. Check & verify dimension & levels prior to the commencement of any work. All discrepancies to be reported to the drafting office.
 Copyright in and to these plans remains at all times with Masterton Homes Pty Ltd and these plans shall not be used or be permitted to be used for any other purpose other than for the erection of the home the subject of these plans by or on behalf of Masterton Homes Pty Ltd.

