

LEGEND:

- TEMPORARY W.C.
- SITE OFFICE
- PROVISIONAL AREA FOR STOCKPILING OF MATERIALS
- GEOTEXTILE TRADE WASTE RECEPTACLE
- SEDIMENT CONTROL FENCE
- TREES TO BE REMOVED
- TREES TO BE RETAINED
- VC AND STABILISED ENTRY

SOIL EROSION NOTES

TOPSOIL SHALL BE STRIPPED AND STOCKPILED OUTSIDE HAZARD AREAS SUCH AS DRAINAGE LINES. THIS TOPSOIL IS TO BE RE-SPREAD LATER ON AREAS TO BE REVEGETATED AND STABILISED ONLY. (i.e ALL FOOTPATHS, BATTERS, SITE, REGRAIDING AREAS, DRAINAGE RESERVES AND CHANNELS). TOP SOIL SHALL NOT BE SPREAD ON ANY OTHER AREAS UN-SPECIFICALLY INSTRUCTED BY THE SUPERINTENDENT. IF THEY ARE TO REMAIN FOR LONGER THAN ONE MONTH STOCKPILES SHALL BE PROTECTED FROM EROSION BY COVERING THEM WITH A MULCH AND HYDROSEEDING AND, IF NECESSARY, BY LOCATING BANKS OR DRAINS UPSLOPE TO DIVERT THE RUNOFF AROUND THEM. IN SOME CIRCUMSTANCES IT MAY BE NECESSARY TO PLACE BANKS OR DRAINS DOWN STREAM OF A STOCKPILE TO RETARD SEDIMENT LADEN RUNOFF. THE CONTRACTOR SHALL REGULARLY MAINTAIN ALL SEDIMENT AND EROSION CONTROL DEVICES AND REMOVE ACCUMULATED SILT FROM SUCH DEVICES BEFORE NO MORE THAN 80% OF THEIR CAPACITY IS LOST. ALL THE SILT REMOVED SHALL BE DISPOSED OF AS DIRECTED BY THE SUPERINTENDENT. (NO SILT SHALL BE PLACED OUTSIDE THE LIMITS OF WORKS). THE PERIOD FOR MAINTAINING THESE DEVICES SHALL BE AT LEAST UNTIL ALL DISTURBED AREAS ARE REVEGETATED AND FURTHER AS MAY BE DIRECTED BY THE SUPERINTENDENT OR COUNCIL

NOTE

- ALL EROSION AND SEDIMENT CONTROL MEASURES TO BE INSPECTED AND MAINTAINED DAILY BY CONTRACTOR/SITE MANAGER.
- MINIMISE DISTURBED AREAS.
- ALL STOCKPILES TO BE CLEAR FROM DRAINS, GUTTERS AND FOOTPATHS.
- DRAINAGE IS TO BE CONNECTED TO STORM WATER SYSTEM AS SOON AS POSSIBLE.
- ROADS AND FOOTPATHS TO BE SWEEPED DAILY UNDER SECTION 16 OF THE CLEAN WATERS ACT HEAVY FINES, INCLUDING A \$600 ON THE SPOT FINE, MAY BE IMPOSED IF A PERSON ALLOWS SOIL, CEMENT SLURRY OR OTHER BUILDING MATERIALS TO BE PUMPED, DRAINED OR ALLOWED TO ENTER THE STORM WATER SYSTEM.

TREES HAVE BEEN OMITTED FOR CLARITY. REFER ARCHITECTURAL PLANS FOR TREES TO BE REMOVED AND RETAINED REFER SITE PLAN

THIS DRAWING SHALL BE READ IN CONJUNCTION WITH THE FOLLOWING:- ARCHITECTURAL PLANS CONTOUR AND DETAIL SURVEY

NOTE

WHEELS OF VEHICLES LEAVING SITE TO BE WASHED DOWN TO PREVENT SEDIMENT LEAVING SITE

CONSTRUCTION NOTES

- SD6-7 SEDIMENT FENCE
- CONSTRUCT SEDIMENT FENCE AS CLOSE AS POSSIBLE AND PARALLEL TO THE CONTOURS OF THE SITE
 - DRIVE 1.5 m LONG STAR PICKETS INTO GROUND Max 3m Ctrs.
 - DIG A 150 mm DEEP TRENCH ALONG THE UPSLOPE LINE OF THE FENCE FOR THE BOTTOM OF THE FABRIC TO BE ENTRENCHED. BACKFILL TRENCH OVER THE BASE OF FABRIC.
 - FIX SELF SUPPORTING GEOTEXTILE TO UPSLOPE SIDE OF POSTS WITH WIRE TIES OR AS RECOMMENDED BY GEOTEXTILE MANUFACTURER.
 - JOIN SECTIONS OF FABRIC AT A SUPPORT POST WITH A MIN. LAP OF 150 mm.

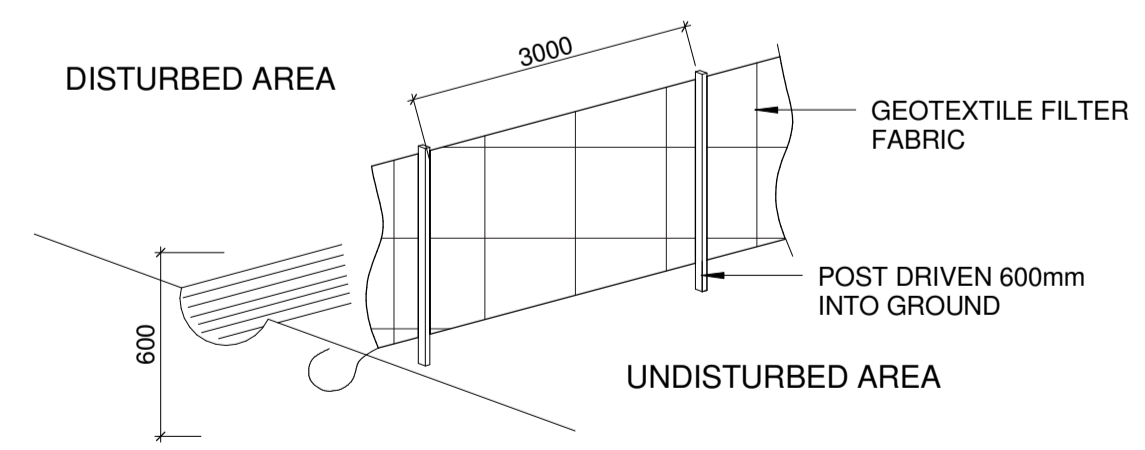

SEDIMENT CONTROL FENCE
NOT TO SCALE

1 EROSION SEDIMENT CONTROL PLAN
WMP 01/01 1 : 100

Universal Property
GROUP PTY LTD
Office Address: 1/129 Magowar Road, Girraween, Sydney NSW - 2145
Postal Address: PO Box 270, Wentworthville, Sydney NSW - 2145
T: +612 9639 2485 F: +612 9669 4762
info@bathla.com.au

GENERAL NOTES

- ALL DIMENSIONS AND FLOOR AREAS TO BE VERIFIED BUILDER PRIOR TO THE COMMENCEMENT OF ANY BUILDING WORK.
- ANY DISCREPANCIES ARE TO BE CONFIRMED BY THE DESIGNER.
- LEVELS SHOWN ARE APPROXIMATE UNLESS ACCOMPANIED BY REDUCED LEVELS BY A REGISTERED SURVEYOR.
- FIGURED DIMENSIONS ARE TO BE TAKEN IN PREFERENCE TO SCALING.
- ALL BOUNDARY CLEARANCE MUST BE VERIFIED BY THE SURVEYOR PRIOR TO THE COMMENCEMENT OF ANY BUILDING WORK.
- WHERE ENGINEERING OR HYDRAULIC DRAWINGS ARE REQUIRED, SUCH MUST TAKE PREFERENCE TO THIS DRAWING.
- STORMWATER TO BE CONNECTED AND DISCHARGED TO COUNCIL'S REQUIREMENTS AND TO AS 3500.3
- ALL SERVICES TO BE LOCATED AND VERIFIED BY THE BUILDER WITH THE RELEVANT AUTHORITIES PRIOR TO THE COMMENCEMENT OF ANY BUILDING.

ISSUED FOR:

COUNCIL MEETING

DEVELOPMENT APPLICATION

SECTION 96

CONSTRUCTION ONLY

ISSUE	AMENDMENTS	DATE	DRAWN	CHKD
R01	ISSUED FOR DEVELOPMENT APPLICATION	21/02/2014	TS/PI	CK

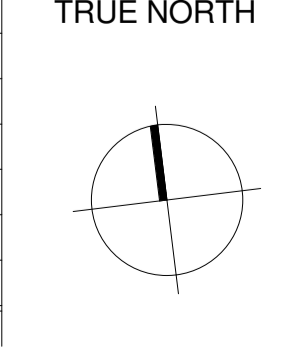

DRAWING NUMBER:
WMP 01/01

DRAWING TITLE:
EROSION SEDIMENT CONTROL PLAN

SCALE
1:100@A1

DATE
FEB 2014

ISSUE
R01

PROJECT
**LOT 22 IN DP 1166456
23 GHERA ROAD
CADDENS**