

CUT & FILL BUILDING AREA TO RL 40.015 APPROX. TO CREATE LEVEL BUILDING PLATFORM FOR WAFFLE POD SLAB

CUT - LINE

NOTE: THIS SITING IS SUBJECT TO THE DEVELOPERS APPROVAL. BUILDER TO OBTAIN PRIOR TO PERMIT APPLICATION.

NOTE: THIS SITING HAS BEEN PREPARED BASED ON THE ADJOINING PROPERTIES/Y BEING VACANT. SHOULD A SIGNIFICANT AMOUNT OF TIME PASS BEFORE THE BUILDING PERMIT IS APPLIED FOR, AN UPDATED SURVEY MAY BE REQUIRED TO CONFIRM THE ADJOINING PROPERTIES/Y STATUS. THE RESCODE REQUIREMENTS MAY NEED TO BE RE-EVALUATED AND MAY CAUSE CHANGES TO THE SITING/HOUSE.

NOTE: THIS SITING HAS BEEN PREPARED BASED ON THE AVAILABLE INFORMATION FROM THE RELEVANT LOCAL COUNCIL AND/OR OTHER AUTHORITIES THAT IS NOT COMPLETE OR HAVE NOT BEEN FINALISED DUE TO THE TITLES NOT YET BEEN RELEASED IN THIS SUBDIVISION. ONCE THIS INFORMATION IS RELEASED IT WILL BE EXAMINED. THIS MAY REVEAL THE REQUIREMENT FOR ADDITIONAL WORKS AND THE SITING MAY CHANGE.

- (A) EASEMENT FOR ACCESS & MAINTENANCE 0.9 WIDE
- (C) EASEMENT TO DRAIN WATER 2 WIDE
- (CI) EASEMENT TO DRAIN WATER 2 WIDE (DPII58660)
- (E) RIGHT OF CARRIAGEWAY 7 WIDE
- (Q) RESTRICTION ON THE USE OF LAND (DPII49528)
- (B) EASEMENT TO DRAIN WATER 1.5 WIDE

PITT STREET

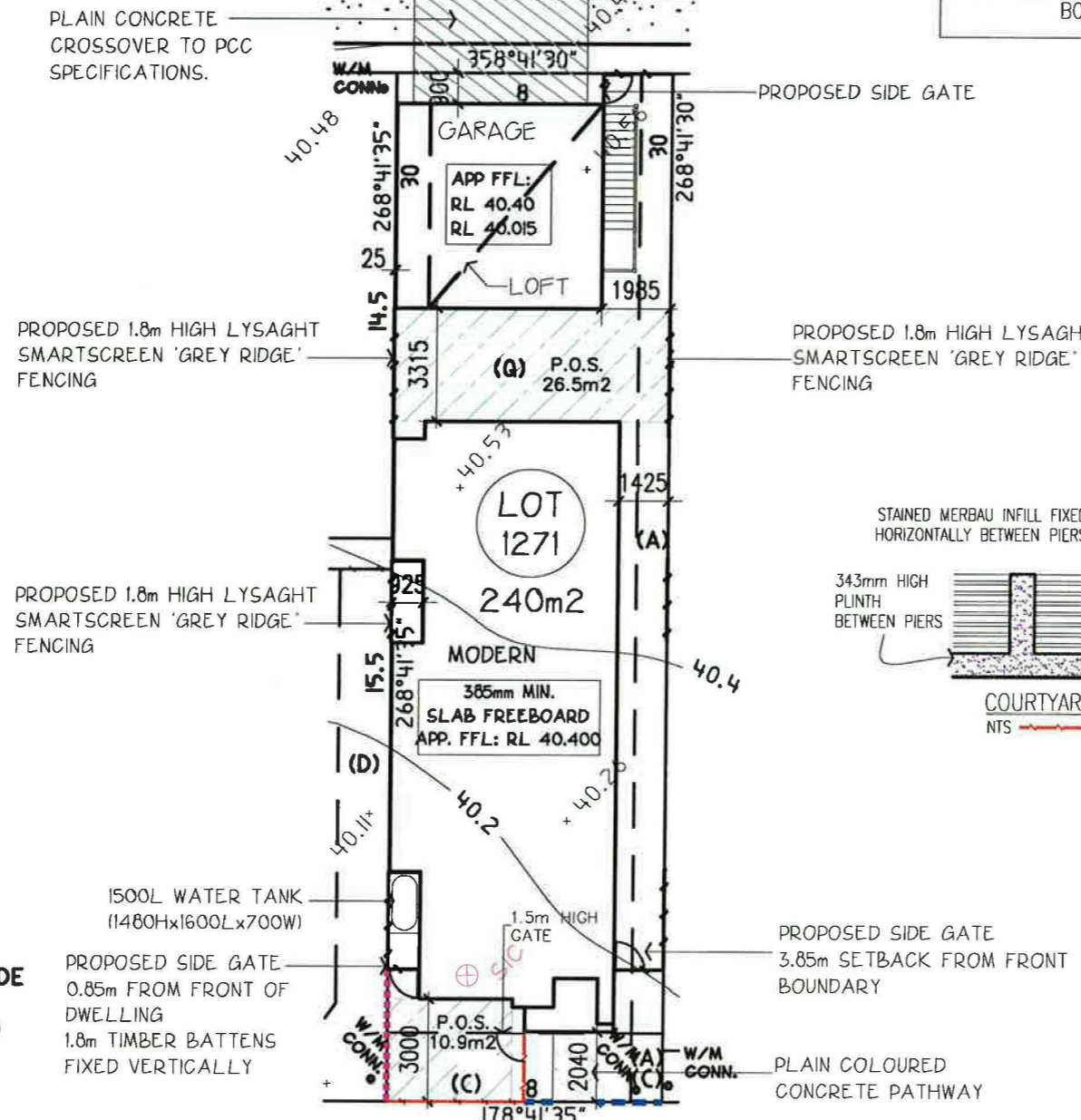

LEGEND:

- PROPOSED 1.8m HIGH LYSAGHT SMARTSCREEN FENCING
- 1.5m HIGH COURTYARD FENCING
- 1.2m HIGH FRONT BOUNDARY FENCING

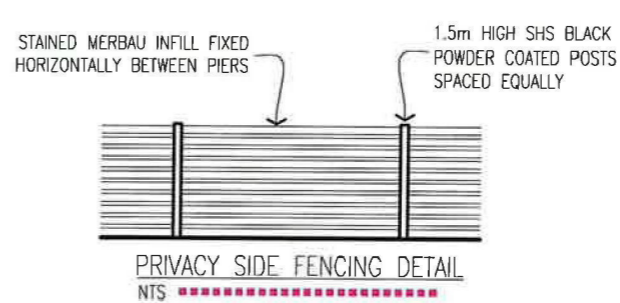
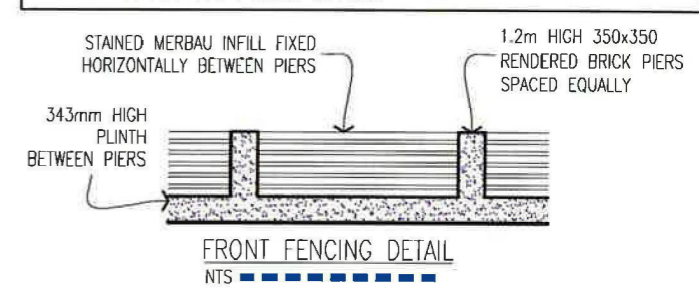
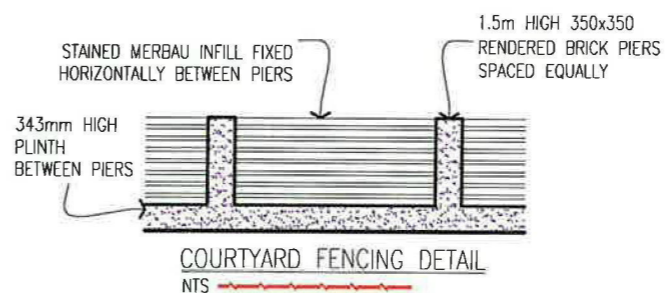

TABLE OF BASIX COMMITMENTS

PROJECT ADDRESS: LOT 1271 LAKESIDE PARADE JORDAN SPRINGS
CERTIFICATE NO.: 477631S

WATER

- DEVELOPMENT TO BE CONNECTED TO 1500LT RAINWATER TANK.
- RAINWATER TANK CONFIGURED TO COLLECT AT LEAST 150.0m² ROOF RUN OFF.
- TOILETS, WASHING MACHINE AND 1 OUTDOOR TAP TO BE CONNECTED TO THE RAINWATER TANK.
- 3 STAR SHOWER HEADS & KITCHEN TAPS, 4 STAR TOILETS, AND 5 STAR BASIN TAPS.

THERMAL

- ROOF INSULATION: NONE.
- CEILING INSULATION: R3.5
- WALL INSULATION: R2.0
- EXTERNAL WALL: BRICK VENEER COLOUR: DARK
- ROOFING: TILED COLOUR: DARK
- GLAZING: ALL ALUMINIUM WINDOWS TO BE SINGLE CLEAR GLAZED WITH U VALUE OF 6.57 & SHGC OF 0.74
- TIMBER WINDOWS TO MASTER SUITE AND REAR FAMILY / DINING STACKER DOORS TO BE SINGLE, CLEAR GLAZED, TIMBER FRAMED WITH A U VALUE OF 5.55 AND SHGC OF 0.73

ENERGY

- HOT WATER SYSTEM: GAS INSTANTANEOUS HWS WITH A PERFORMANCE OF 5 STARS OR BETTER.
- AC DUCTING ONLY TO BE INSTALLED.
- KITCHEN: INDIVIDUAL FAN, DUCTED (RANGEHOOD). OPERATION CONTROL, MANUAL SWITCH.
- BATHROOM (II): INDIVIDUAL FAN, NOT DUCTED. OPERATION CONTROL, MANUAL SWITCH.
- LAUNDRY: INDIVIDUAL FAN, DUCTED TO FACADE..
- WINDOW AND/OR SKYLIGHT TO KITCHEN FOR NATURAL LIGHTING.
- WINDOW AND/OR SKYLIGHT TO BATHROOMS (2)/TOILET (S) FOR NATURAL LIGHTING.
- GAS COOKTOP AND ELECTRIC OVEN TO BE INSTALLED IN THE KITCHEN.
- OUTDOOR CLOTHES LINE.
- FLUORESCENT LIGHTING TO 4 BEDROOMS, BATHROOMS/TOILETS AND LAUNDRY.
- WELL VENTILATED FRIDGE SPACE.

SITE COVERAGE ANALYSIS

Roof Area	171.6 sqm	71.5 %
Ground Floor	103.9 sqm	
First Floor	90.8 sqm	
Garage	35.8 sqm	
Loft	27.6 sqm	
Porch	2.1 sqm	
Balcony	N/A sqm	
Building	141.8 sqm	59.1 %
Hard Surface	8.7 sqm	3.6 %
Permeable	74.5 sqm	37.3 %
Total Area	240.0 sqm	100.0 %
Overall Block Size	240.0 sqm	

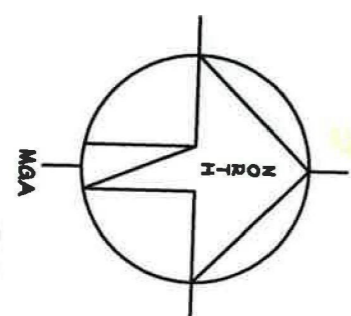

LAKESIDE PARADE

DATE	REVISION	DRAWN



© Henley Arch P/L All rights reserved - this set of drawings is COPYRIGHT. Apart from use by the party to whom this report is addressed for the purpose for which it was requested and any fair dealing as permitted under the Copyright Act no part may be used, reproduced or copied by any means or in any form without prior permission of HENLEY ARCH P/L

SITE PLAN	SHEET 1	HAND LH	Townhouse 3 - Stage 3 (7.5m) Modern	EDGEWATER HOMES PO Box 550 Moorebank NSW 1875 Ph: 9623 7526 Fax:9673 5560
DRAWN BK 28/03/2013			For EDGEWATER HOMES	
CHECKED			At LOT 1271 LAKESIDE PARADE JORDAN SPRINGS	
SCALE				

EXTERNAL COLOUR SCHEDULE

- FACE BRICK AUSTRAL SYMMETRY ASPHALT
- COLORBOND SURFMIST ROOFING, FASCIA AND GUTTERS
- ALUMINIUM WINDOWS JASPER
- TIMBER WINDOWS INTERGRAIN DARK OAK
- FRONT DOOR DULUX GOLDEN BROWN PILES
- GARAGE PANEL DOOR COLORBOND CLASSIC CEDAR
- GARAGE ACCESS DOOR BRISTOL OAK FLATS

- EXTERNAL COLOURS:

-  DULUX LINSEED
-  DULUX STOWE WHITE

FEATURE TILES TO PIER (HYNES CLASSICO DELICATO 300x600 POLISHED PORCELAIN MMLFK0201)

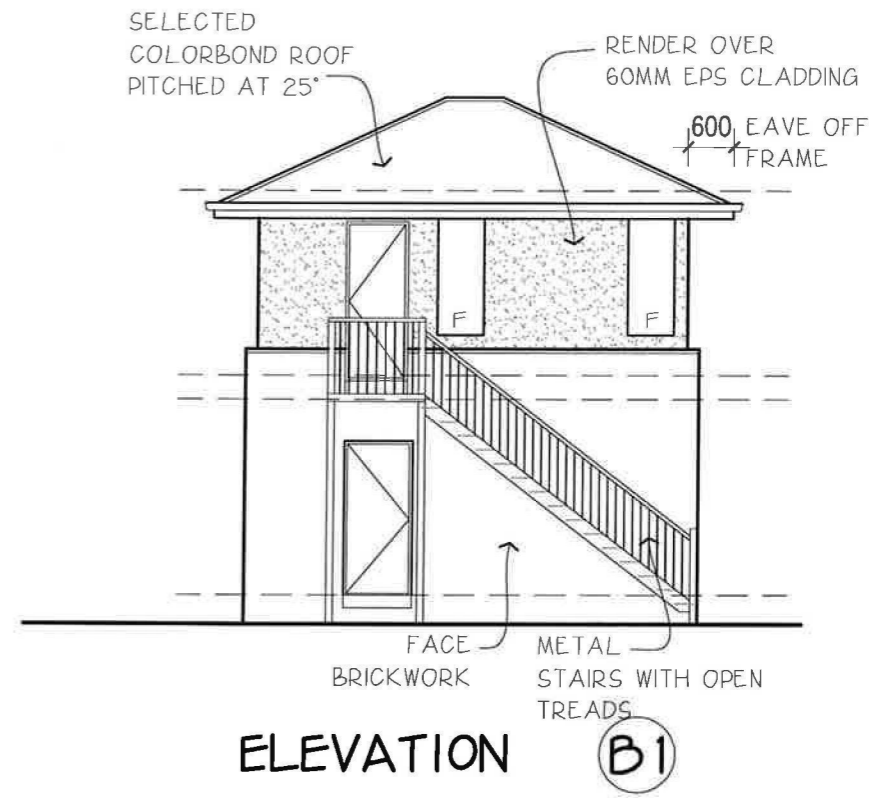
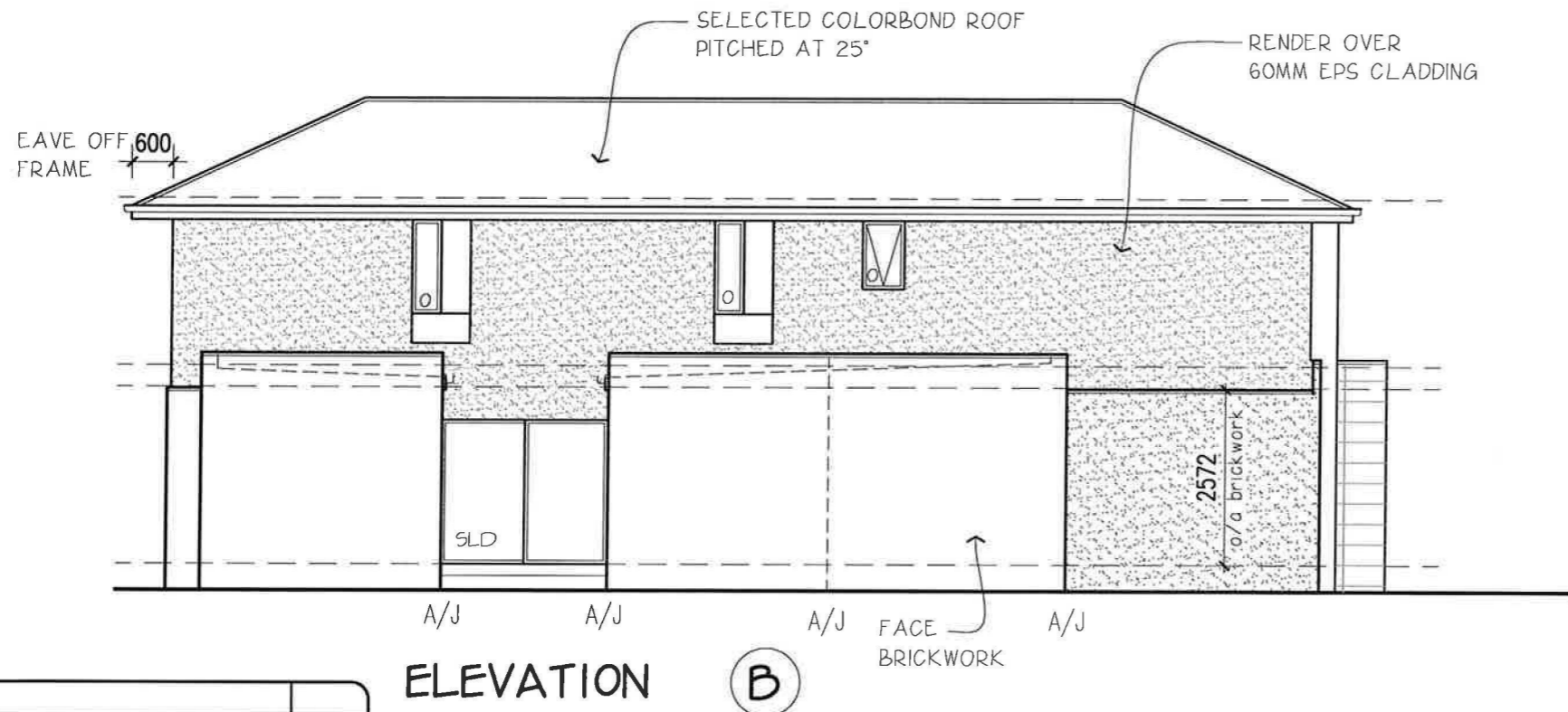
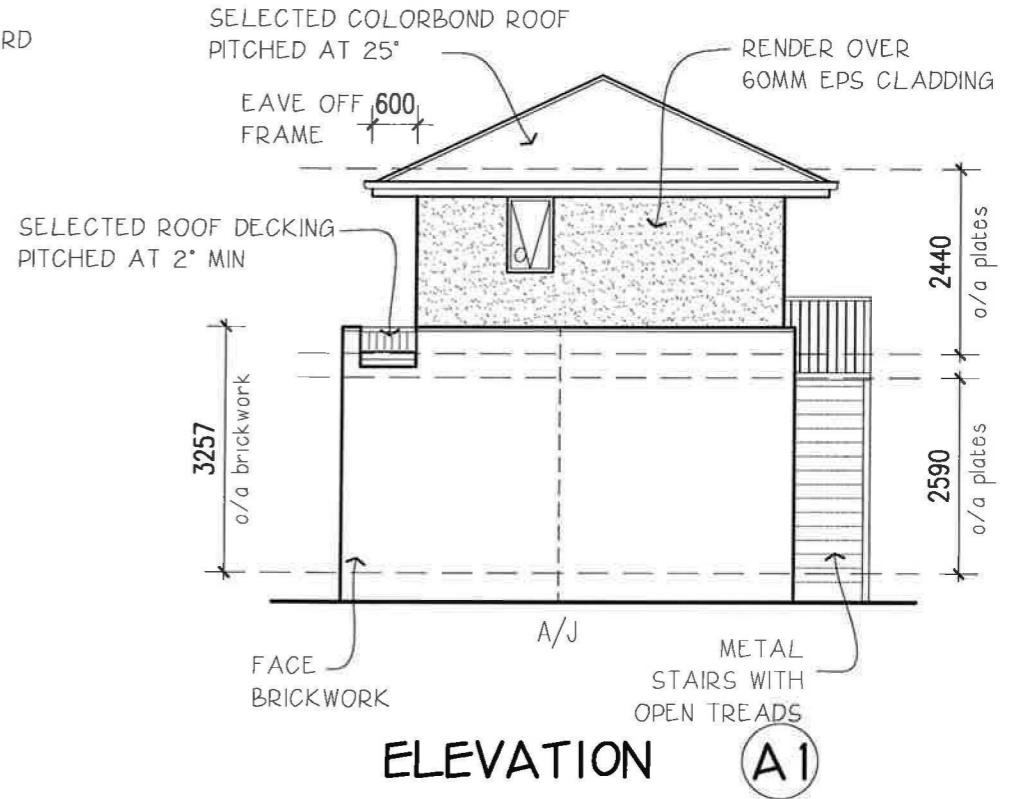
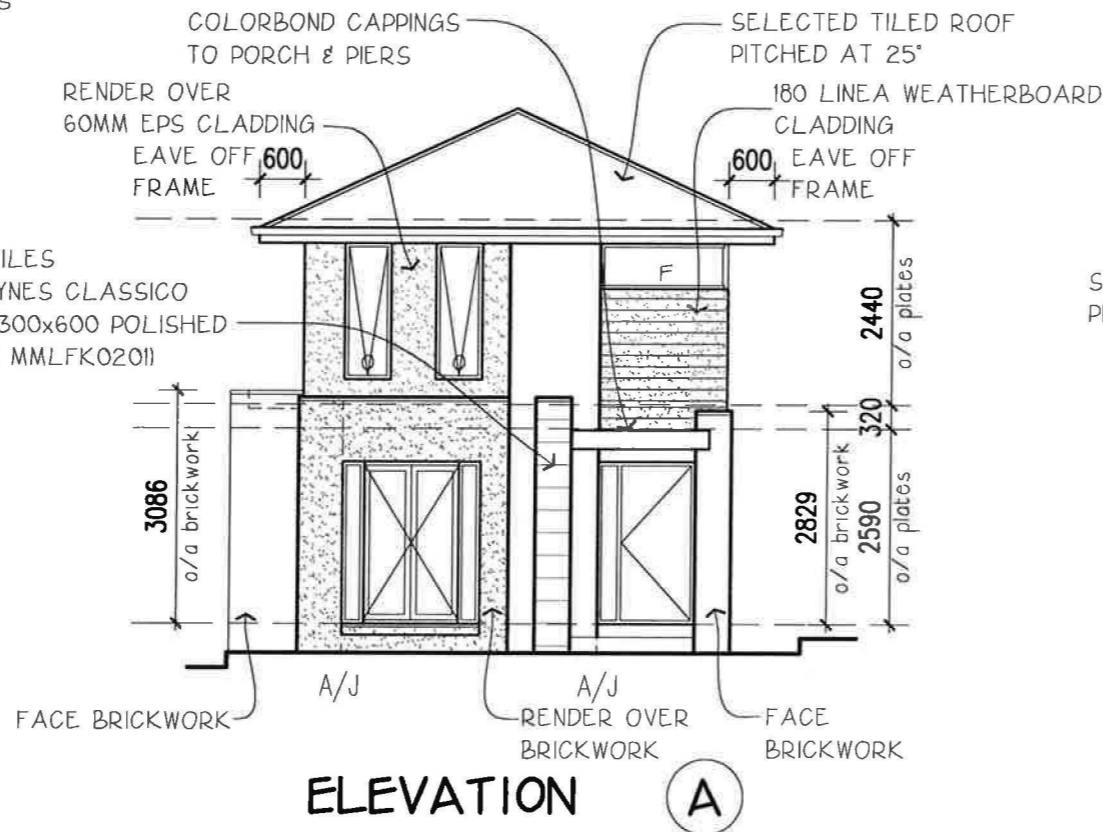

DATE	REVISION	DRAWN

© Henley Arch P/L All rights reserved - this set of drawings is COPYRIGHT. Apart from use by the party to whom this report is addressed for the purpose for which it was requested and any fair dealing as permitted under the Copyright Act no part may be used, reproduced or copied by any means or in any form without prior permission of HENLEY ARCH P/L

ELEVATIONS		SHEET 3	HAND LH	Townhouse 3 - Stage 3 (7.5m) Modern	EDGEWATER HOMES PO Box 550 Moorebank NSW 1875 Ph: 9623 7526 Fax:9673 5560	
DRAWN	BK 28/03/2013	For		EDGEWATER HOMES		
CHECKED	**	At		LOT 1271 LAKESIDE PARADE JORDAN SPRINGS		
SCALE	1:100					



ELEVATION C

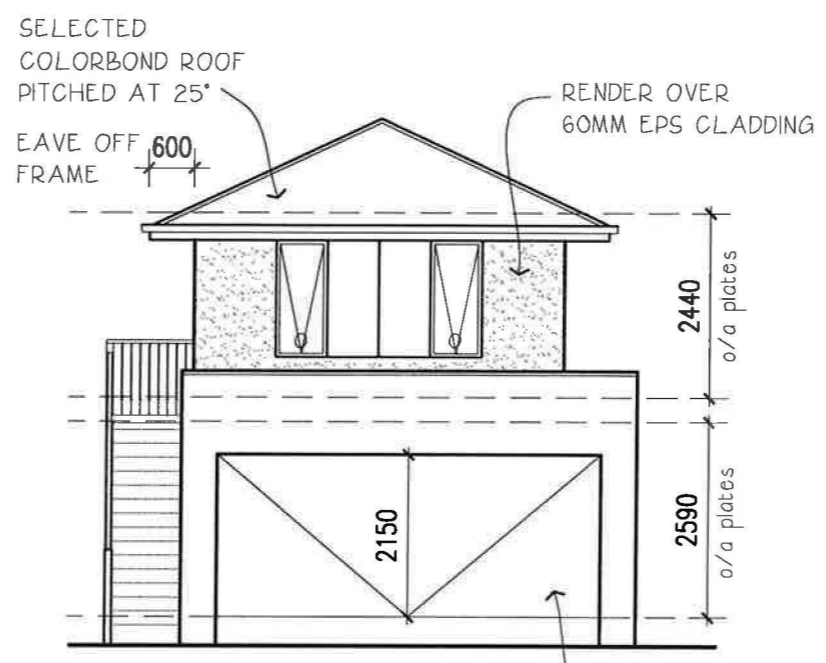

ELEVATION C1

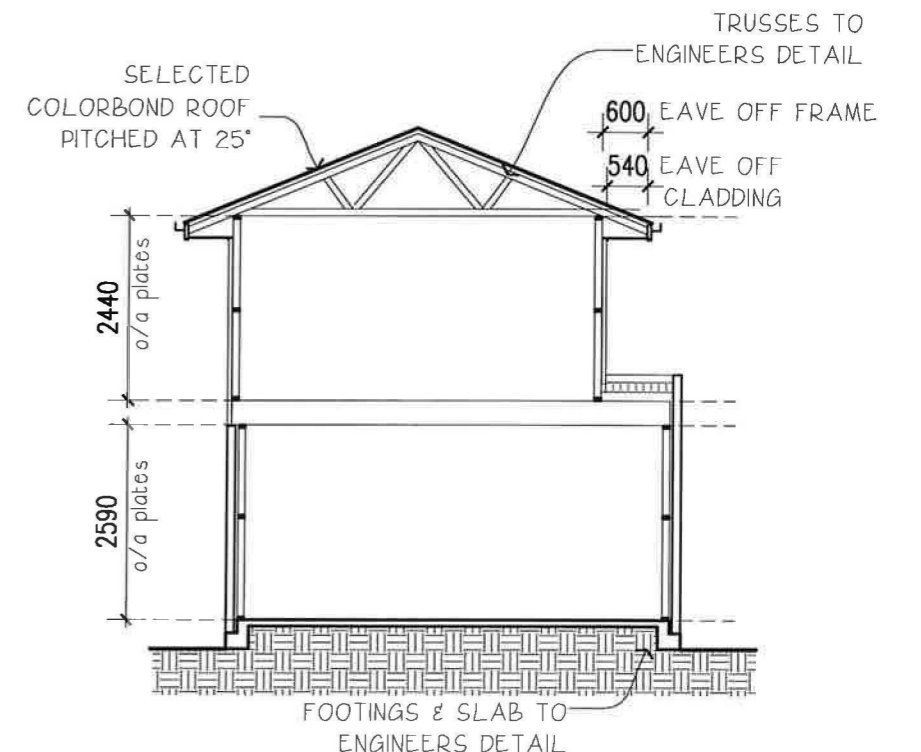

TYPICAL GARAGE SECTION

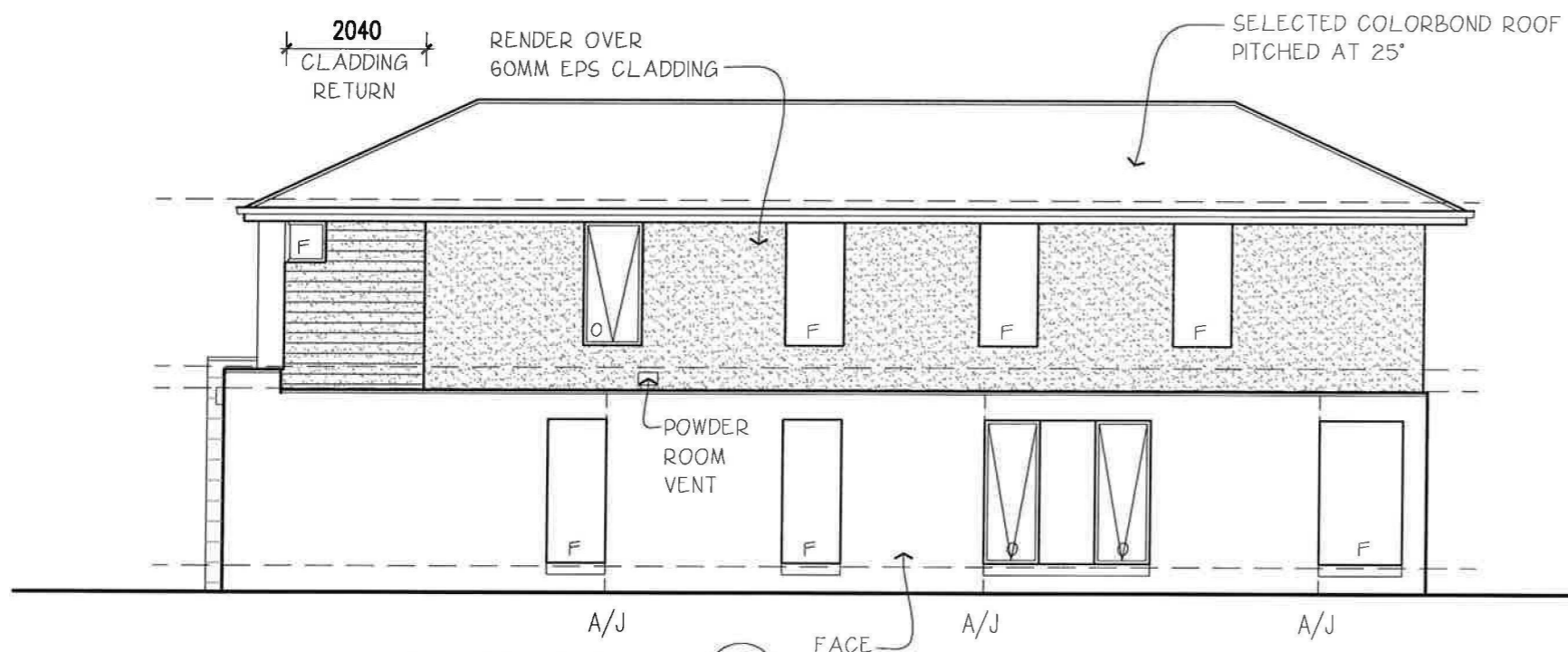

ELEVATION D

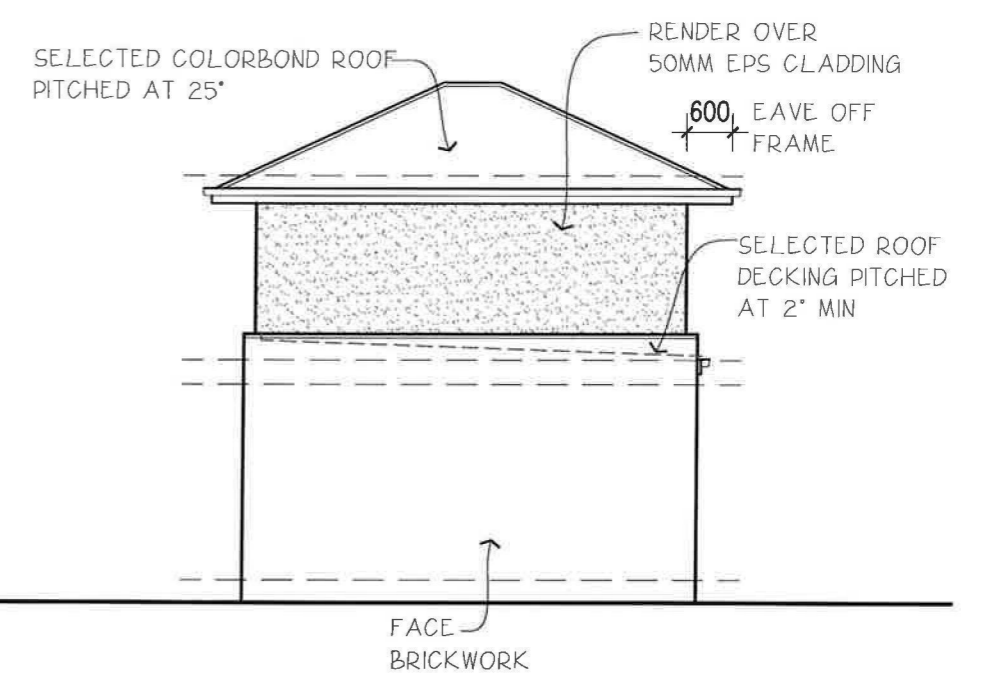

ELEVATION D1

DATE	REVISION	DRAWN

© Henley Arch P/L All rights reserved - this set of drawings is COPYRIGHT. Apart from use by the party to whom this report is addressed for the purpose for which it was requested and any fair dealing as permitted under the Copyright Act no part may be used, reproduced or copied by any means or in any form without prior permission of HENLEY ARCH P/L	ELEVATIONS		SHEET 3A	HAND LH	Townhouse 3 - Stage 3 (7.5m) Modern	EDGEWATER HOMES PO Box 550 Moorebank NSW 1875 Ph: 9623 7526 Fax:9673 5560
	DRAWN BK	28/03/2013	For EDGEWATER HOMES		At LOT 1271 LAKESIDE PARADE JORDAN SPRINGS	
	CHECKED **	SCALE 1:100				

CUT & FILL BUILDING AREA TO RL 40.10 APPROX. TO CREATE LEVEL BUILDING PLATFORM FOR WAFFLE POD SLAB

CUT - LINE

NOTE: THIS SITING IS SUBJECT TO THE DEVELOPERS APPROVAL. BUILDER TO OBTAIN PRIOR TO PERMIT APPLICATION.

NOTE: THIS SITING HAS BEEN PREPARED BASED ON THE ADJOINING PROPERTIES/Y BEING VACANT. SHOULD A SIGNIFICANT AMOUNT OF TIME PASS BEFORE THE BUILDING PERMIT IS APPLIED FOR, AN UPDATED SURVEY MAY BE REQUIRED TO CONFIRM THE ADJOINING PROPERTIES/Y STATUS. THE RESCODE REQUIREMENTS MAY NEED TO BE RE-EVALUATED AND MAY CAUSE CHANGES TO THE SITING/HOUSE.

NOTE: THIS SITING HAS BEEN PREPARED BASED ON THE AVAILABLE INFORMATION FROM THE RELEVANT LOCAL COUNCIL AND/OR OTHER AUTHORITIES THAT IS NOT COMPLETE OR HAVE NOT BEEN FINALISED DUE TO THE TITLES NOT YET BEEN RELEASED IN THIS SUBDIVISION. ONCE THIS INFORMATION IS RELEASED IT WILL BE EXAMINED. THIS MAY REVEAL THE REQUIREMENT FOR ADDITIONAL WORKS AND THE SITING MAY CHANGE.

- (A) EASEMENT FOR ACCESS & MAINTENANCE 0.9 WIDE
- (C) EASEMENT TO DRAIN WATER 2 WIDE
- (CI) EASEMENT TO DRAIN WATER 2 WIDE (DPII58660)
- (E) RIGHT OF CARRIAGEWAY 7 WIDE
- (Q) RESTRICTION ON THE USE OF LAND (DPII49528)
- (B) EASEMENT TO DRAIN WATER 1.5 WIDE

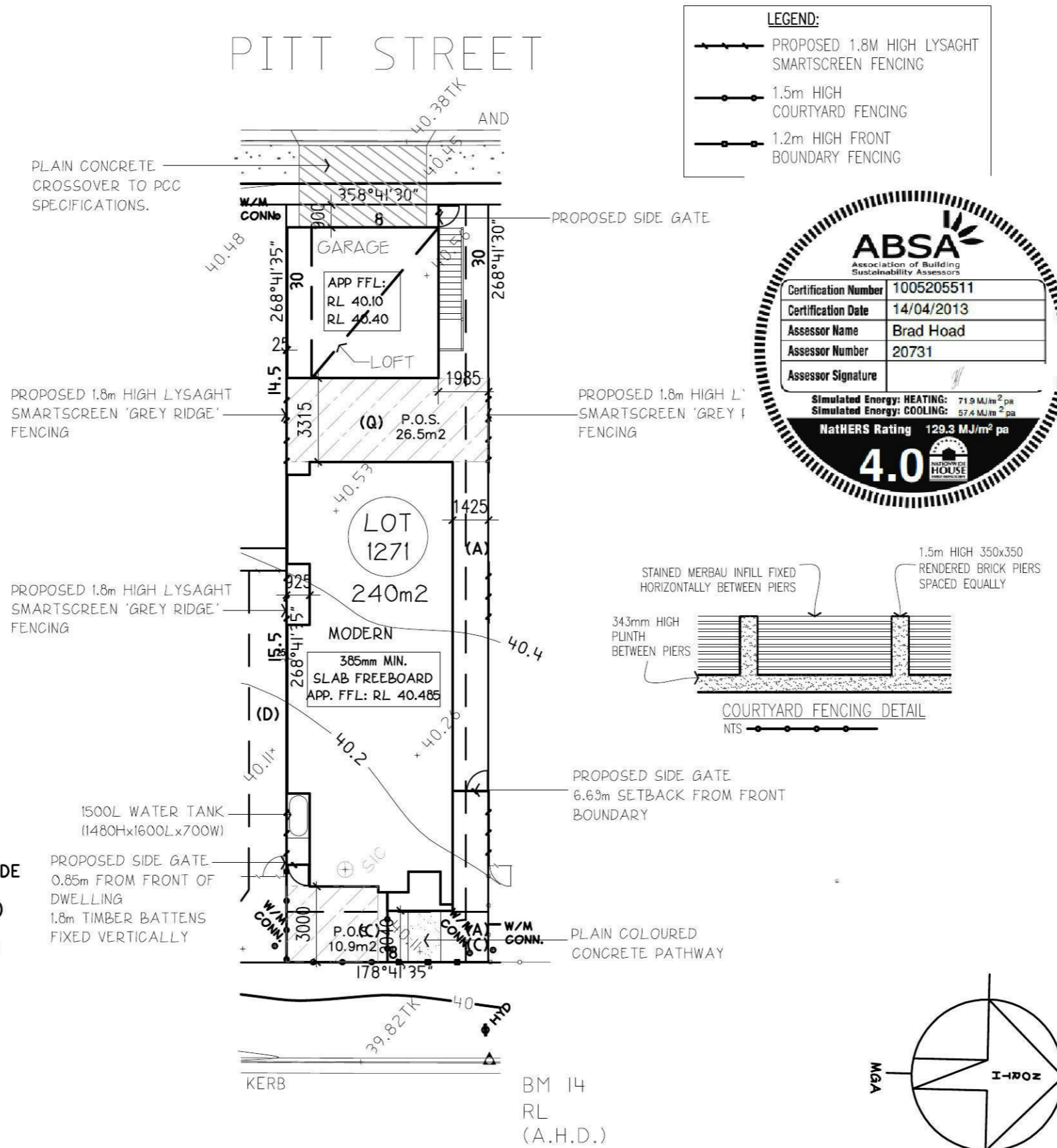

LEGEND:

- PROPOSED 1.8M HIGH LYSAGHT SMARTSCREEN FENCING
- 1.5M HIGH COURTYARD FENCING
- 1.2M HIGH FRONT BOUNDARY FENCING

ABSA
Association of Building Sustainability Assessors

Certification Number	1005205511
Certification Date	14/04/2013
Assessor Name	Brad Hoad
Assessor Number	20731
Assessor Signature	

Simulated Energy: HEATING: 71.9 MJ/m² pa
Simulated Energy: COOLING: 57.4 MJ/m² pa
NatHERS Rating 129.3 MJ/m² pa

4.0
NATIONAL HOUSE ENERGY RATING

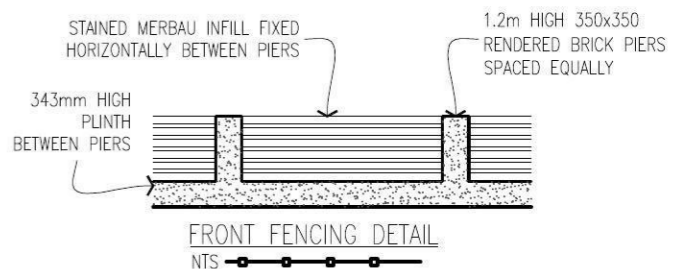
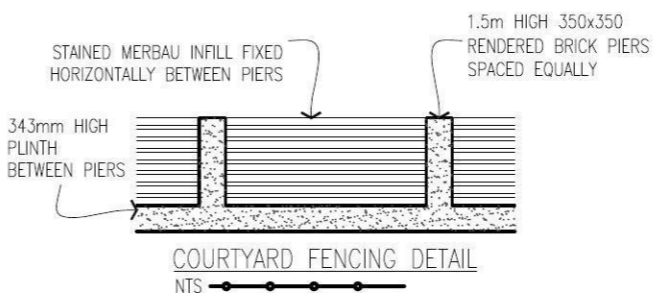

SITE COVERAGE ANALYSIS

Category	Area (sqm)	Percentage (%)
Roof Area	171.6	71.5
Ground Floor	103.9	
First Floor	90.8	
Garage	35.8	
Loft	27.6	
Porch	2.1	
Balcony	N/A	
Building	141.8	59.1
Hard Surface	8.7	3.6
Permeable	74.5	37.3
Total Area	240.0	100.0
Overall Block Size	240.0 sqm	

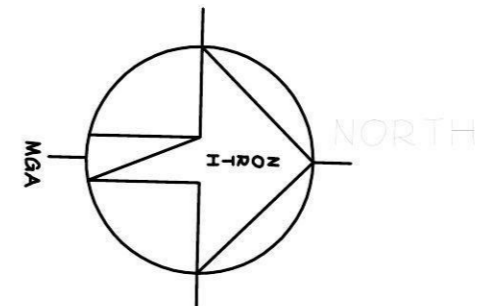

DATE	REVISION	DRAWN

© Henley Arch P/L All rights reserved - this set of drawings is COPYRIGHT. Apart from use by the party to whom this report is addressed for the purpose for which it was requested and any fair dealing as permitted under the Copyright Act no part may be used, reproduced or copied by any means or in any form without prior permission of HENLEY ARCH P/L	SITE PLAN	SHEET 1	HAND LH	Townhouse 3 - Stage 3 (7.5m) Modern	EDGEWATER HOMES PO Box 550 Moorebank NSW 1875 Ph: 9623 7526 Fax:9673 5560
	DRAWN BK 28/03/2013			For EDGEWATER HOMES	
	CHECKED			At LOT 1271 LAKESIDE PARADE JORDAN SPRINGS	

EXTERNAL COLOUR SCHEDULE

- FACE BRICK AUSTRAL SYMMETRY SILVER
- COLORBOND JASPER ROOFING FASCIA AND GUTTERS
- ALUMINIUM WINDOWS JASPER
- TIMBER WINDOWS INTERGRAIN DARK OAK
- FRONT DOOR DULUX MALI
- GARAGE PAINT DOOR COLORBOND SURFMIST
- GARAGE ACCESS DOOR WINDSTOL OAK FLATS

EXTERNAL COLOURS:

- DULUX MALI
- DULUX STOWE WHITE

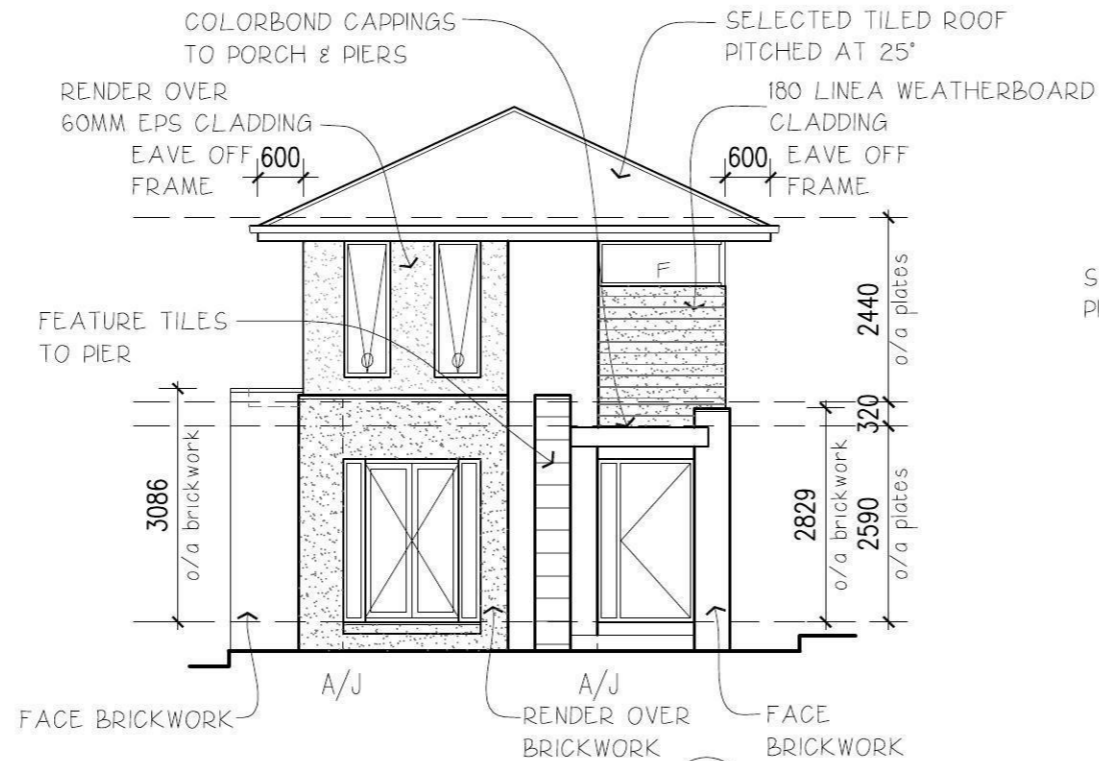

ELEVATION A

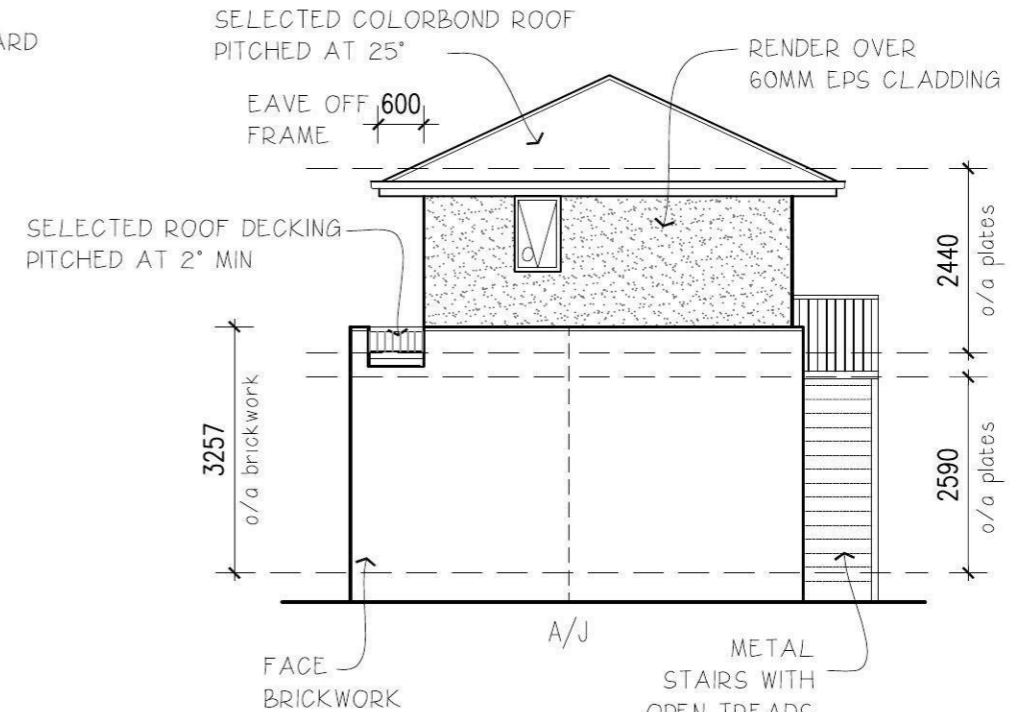

ELEVATION A1

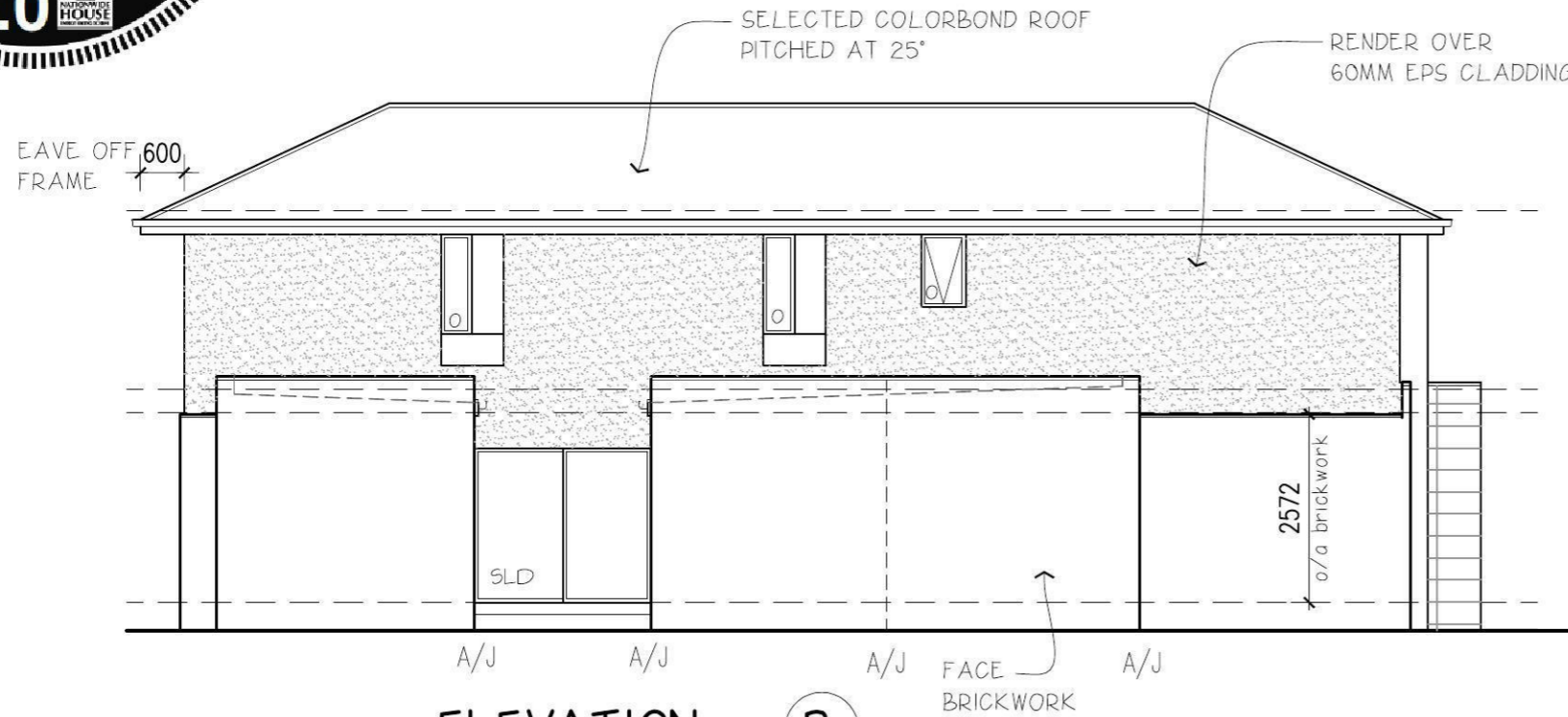

ELEVATION B

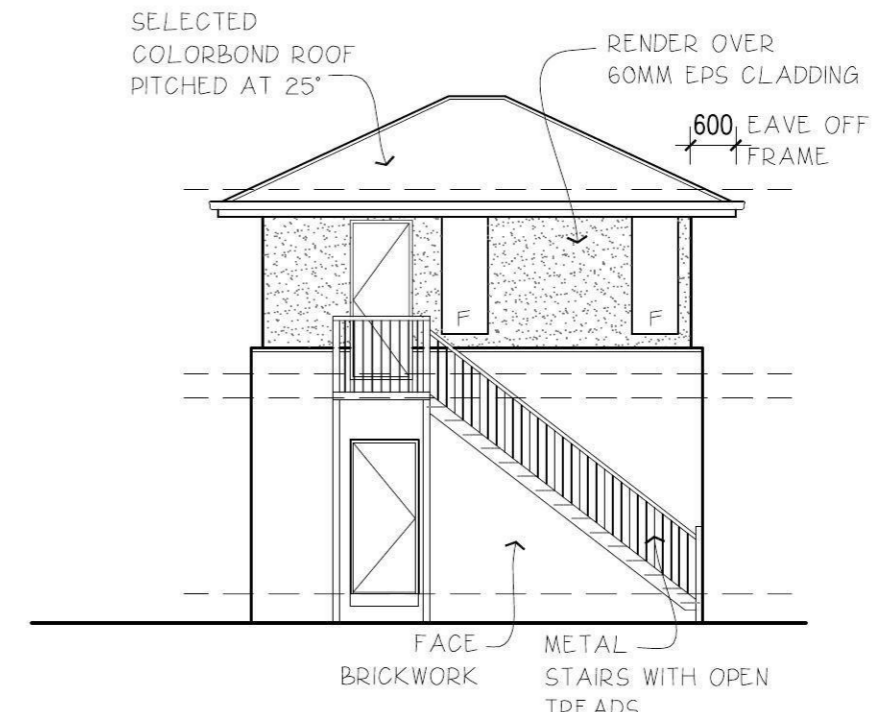

ELEVATION B1

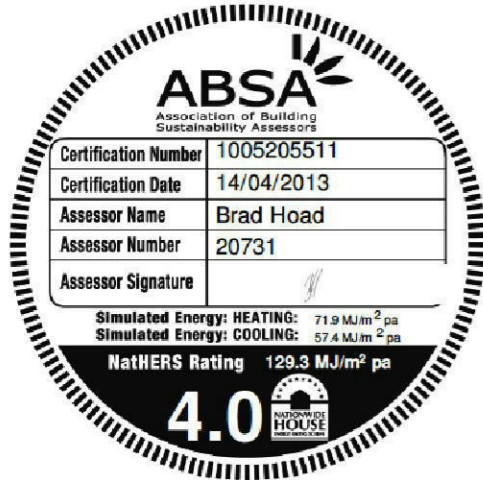

DATE	REVISION	DRAWN

© Henley Arch P/L All rights reserved - this set of drawings is COPYRIGHT. Apart from use by the party to whom this report is addressed for the purpose for which it was requested and any fair dealing as permitted under the Copyright Act no part may be used, reproduced or copied by any means or in any form without prior permission of HENLEY ARCH P/L

ELEVATIONS		SHEET 3	HAND LH	Townhouse 3 - Stage 3 (7.5m) Modern	EDGEWATER HOMES PO Box 550 Moorebank NSW 1875 Ph: 9623 7526 Fax:9673 5560
DRAWN BK	28/03/2013	For EDGEWATER HOMES			
CHECKED **		At LOT 1271 LAKESIDE PARADE JORDAN SPRINGS			



ELEVATION C

C

TIMBER COVERPLATE



ELEVATION C1

C1

SECTIONAL OVERHEAD DOOR

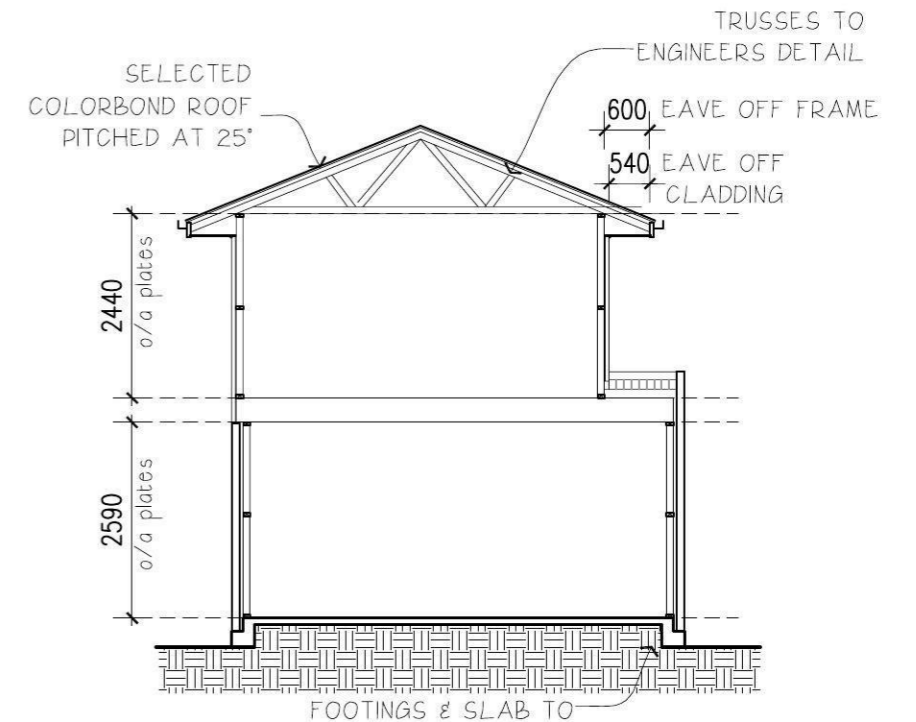

TYPICAL GARAGE SECTION

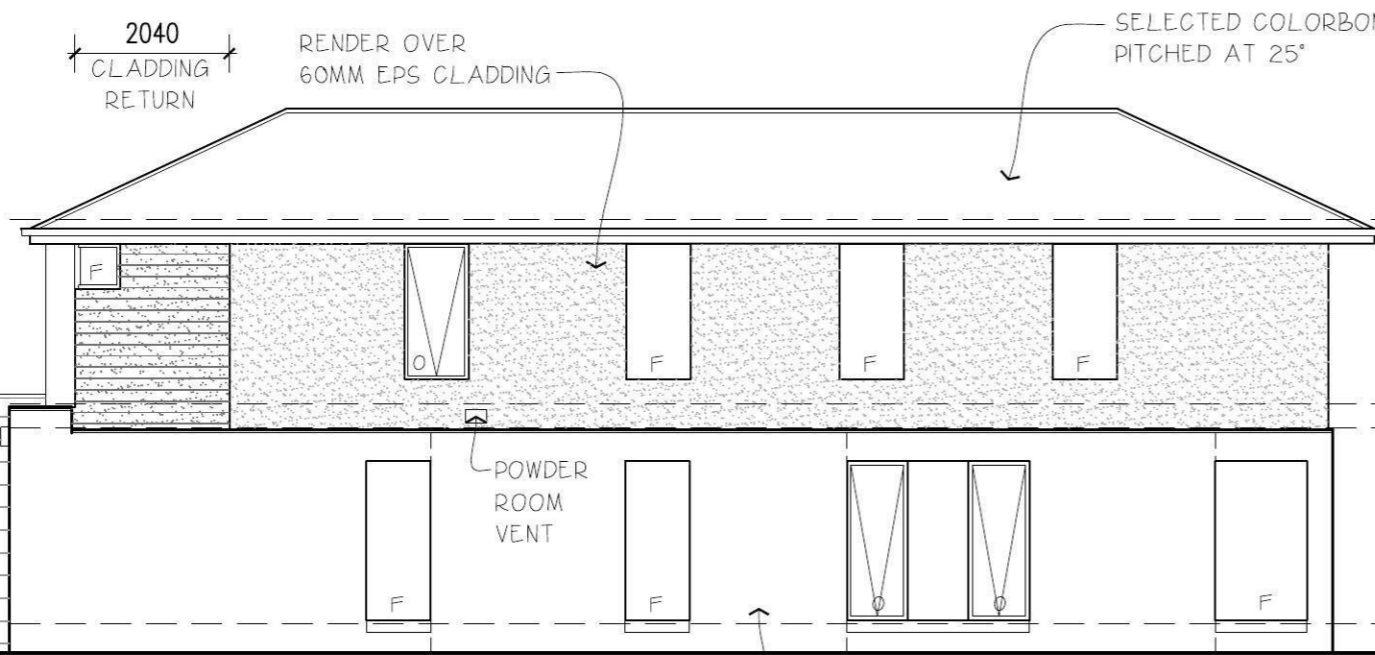

ELEVATION D

D

FACE BRICKWORK

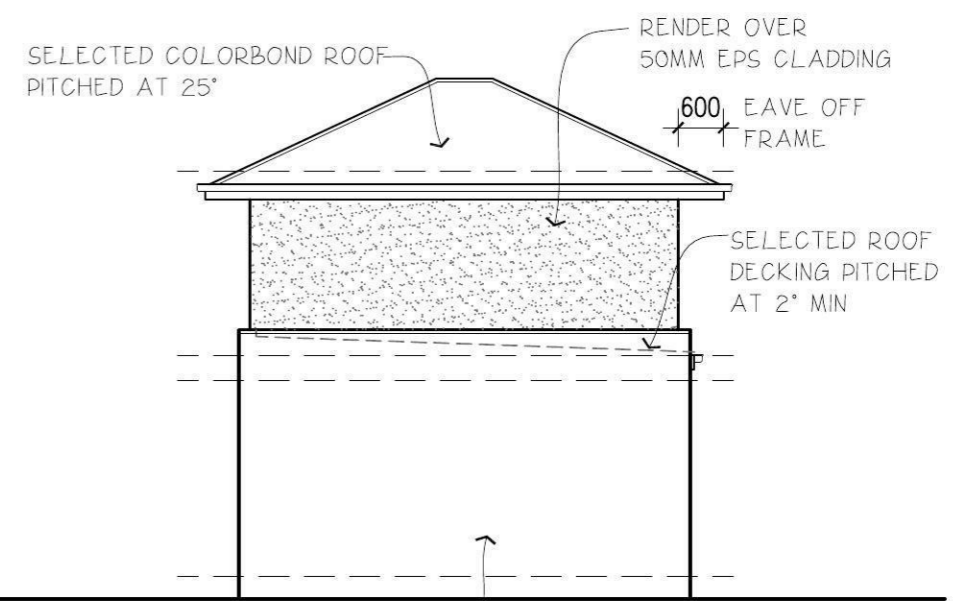

ELEVATION D1

D1

DATE	REVISION	DRAWN

© Henley Arch P/L All rights reserved - this set of drawings is COPYRIGHT. Apart from use by the party to whom this report is addressed for the purpose for which it was requested and any fair dealing as permitted under the Copyright Act no part may be used, reproduced or copied by any means or in any form without prior permission of HENLEY ARCH P/L

ELEVATIONS		SHEET 3A	HAND LH	Townhouse 3 - Stage 3 (7.5m) Modern	EDGEWATER HOMES PO Box 550 Moorebank NSW 1875 Ph: 9623 7526 Fax:9673 5560
DRAWN	BK 28/03/2013	For		EDGEWATER HOMES	
CHECKED	**	At		LOT 1271 LAKESIDE PARADE JORDAN SPRINGS	
SCALE	1:100				

EXTERNAL COLOUR SCHEDULE

- FACE BRICK AUSTRAL SYMMERY SILVER
- COLORBOND JASPER ROOFING FASCIA AND GUTTERS
- ALUMINIUM WINDOWS JASPER
- TIMBER WINDOWS INTERGRAIN DARK OAK
- FRONT DOOR DULUX MALI
- GARAGE PANEL DOOR COLORBOND SURFMIST
- GARAGE ACCESS DOOR WINDSTOL OAK FLATS

EXTERNAL COLOURS:

- DULUX MALI
- DULUX STOWE WHITE

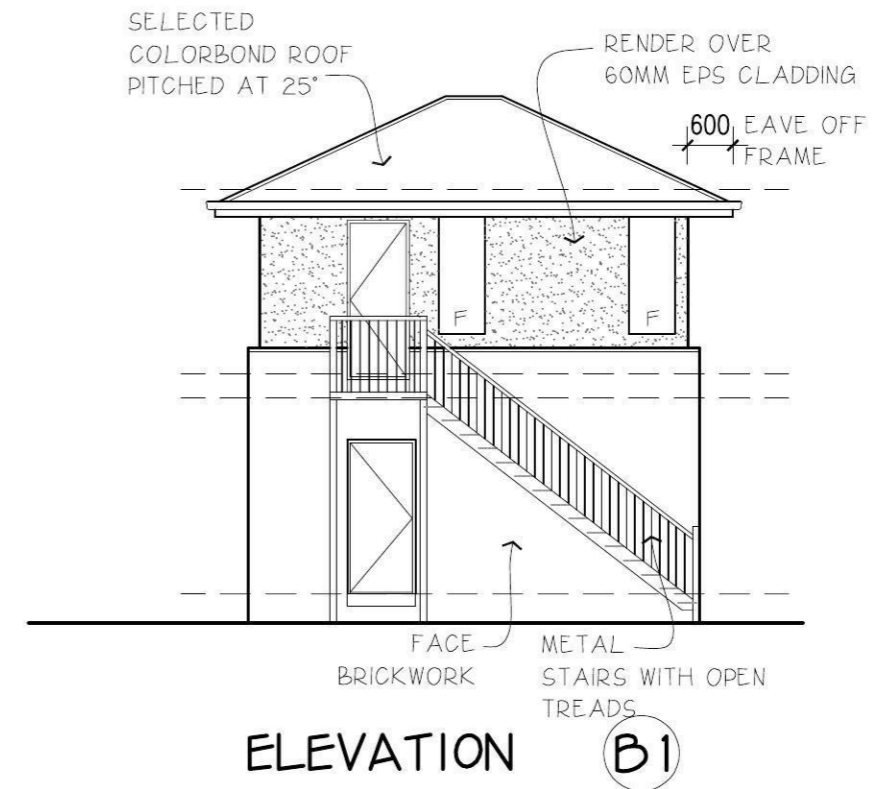
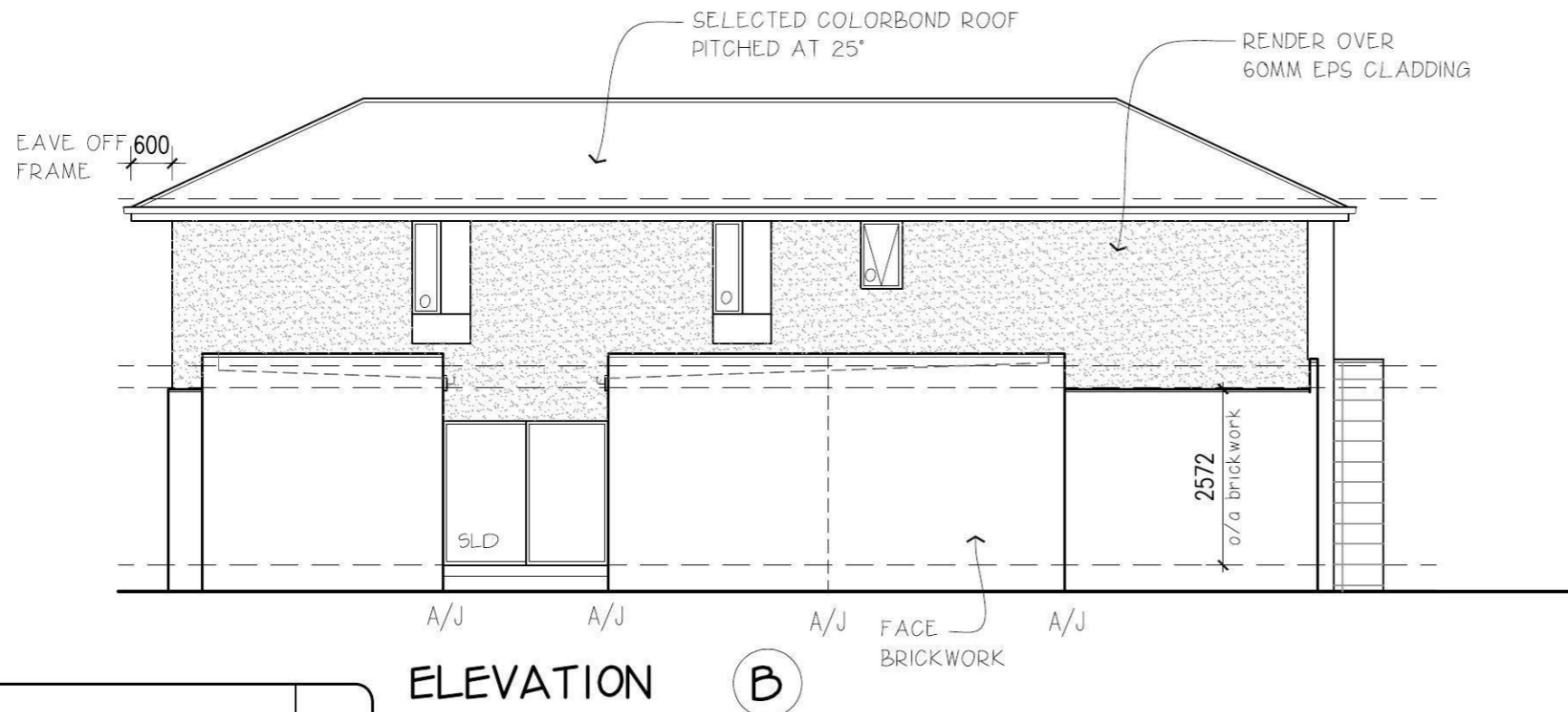
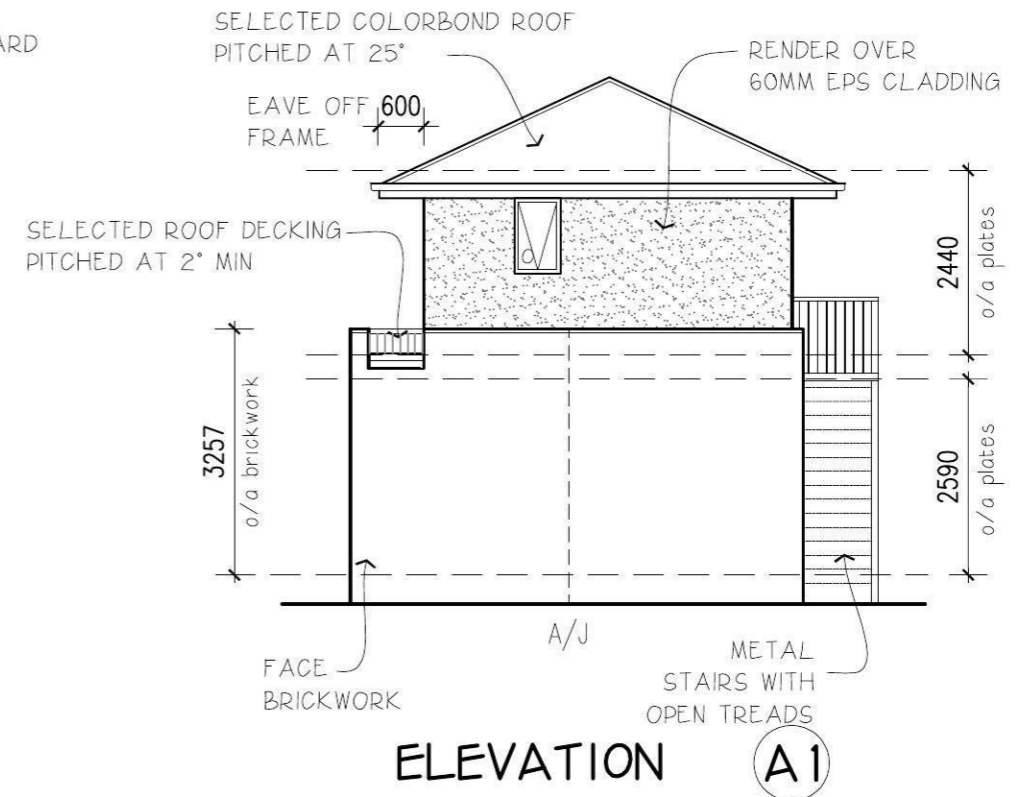
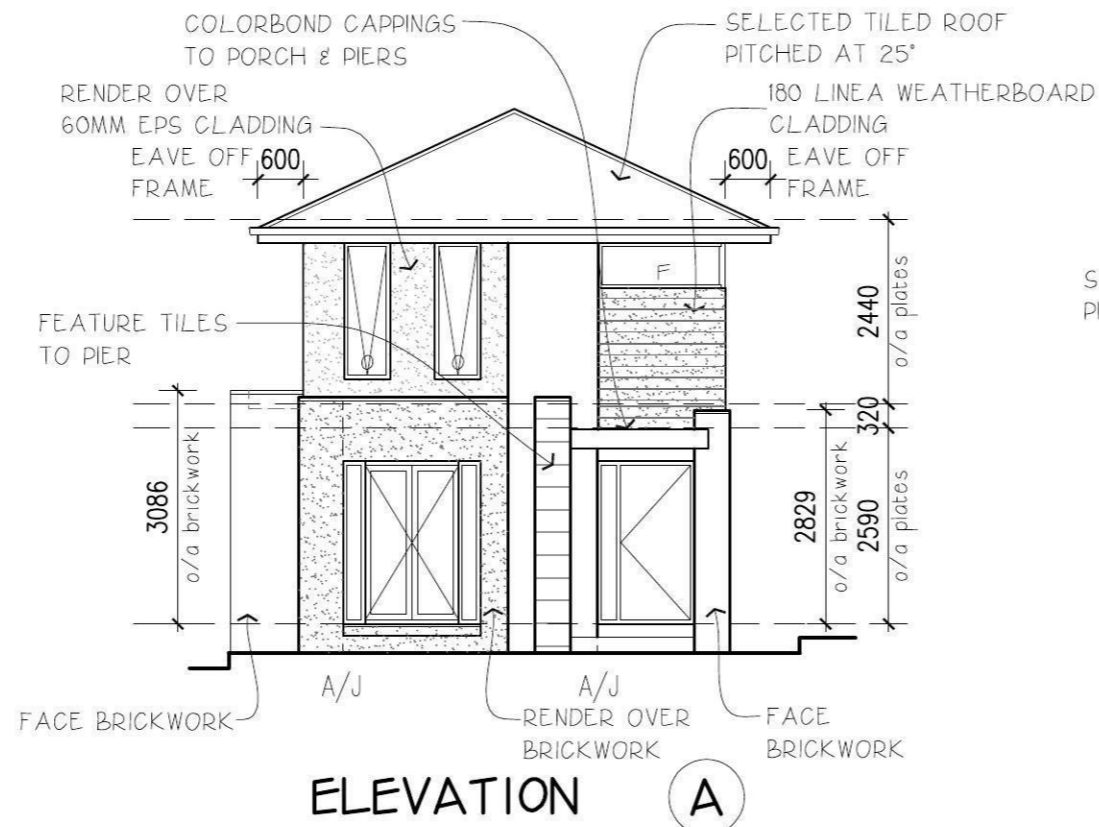

DATE	REVISION	DRAWN

© Henley Arch P/L All rights reserved - this set of drawings is COPYRIGHT. Apart from use by the party to whom this report is addressed for the purpose for which it was requested and any fair dealing as permitted under the Copyright Act no part may be used, reproduced or copied by any means or in any form without prior permission of HENLEY ARCH P/L

ELEVATIONS		SHEET 3	HAND LH	Townhouse 3 - Stage 3 (7.5m) Modern	EDGEWATER HOMES PO Box 550 Moorebank NSW 1875 Ph: 9623 7526 Fax:9673 5560
DRAWN BK	28/03/2013	For EDGEWATER HOMES			
CHECKED **		At LOT 1271 LAKESIDE PARADE JORDAN SPRINGS			
SCALE	1:100				



ELEVATION C

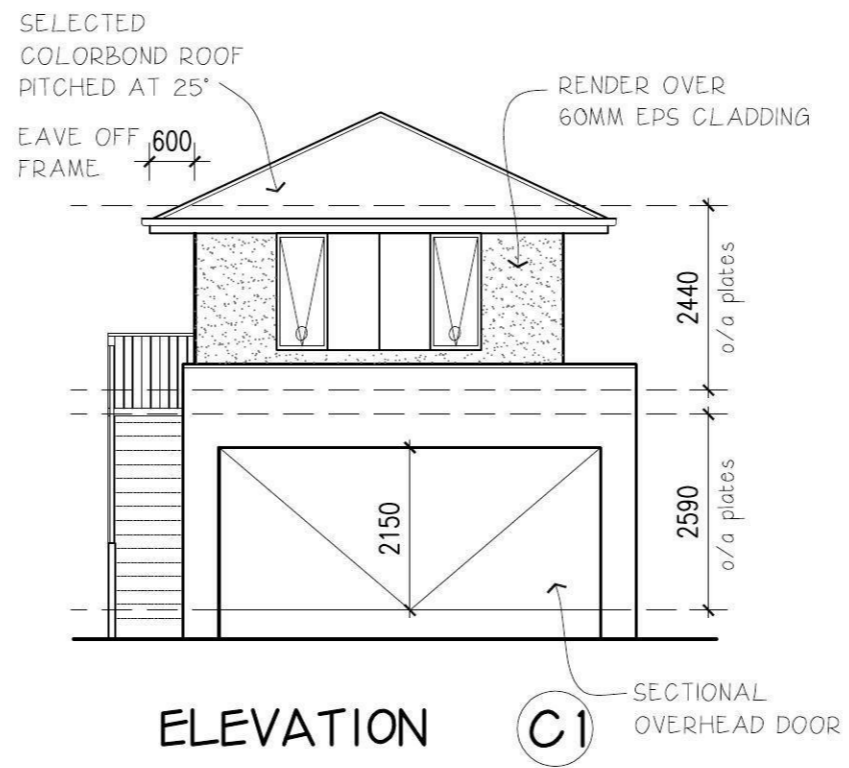

ELEVATION C1

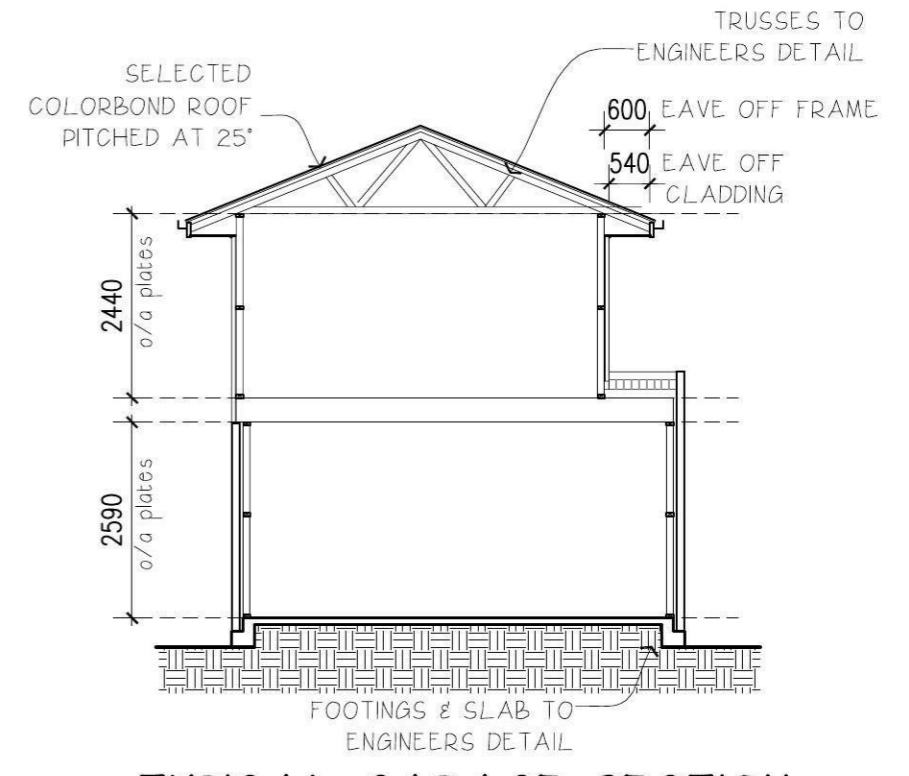

TYPICAL GARAGE SECTION

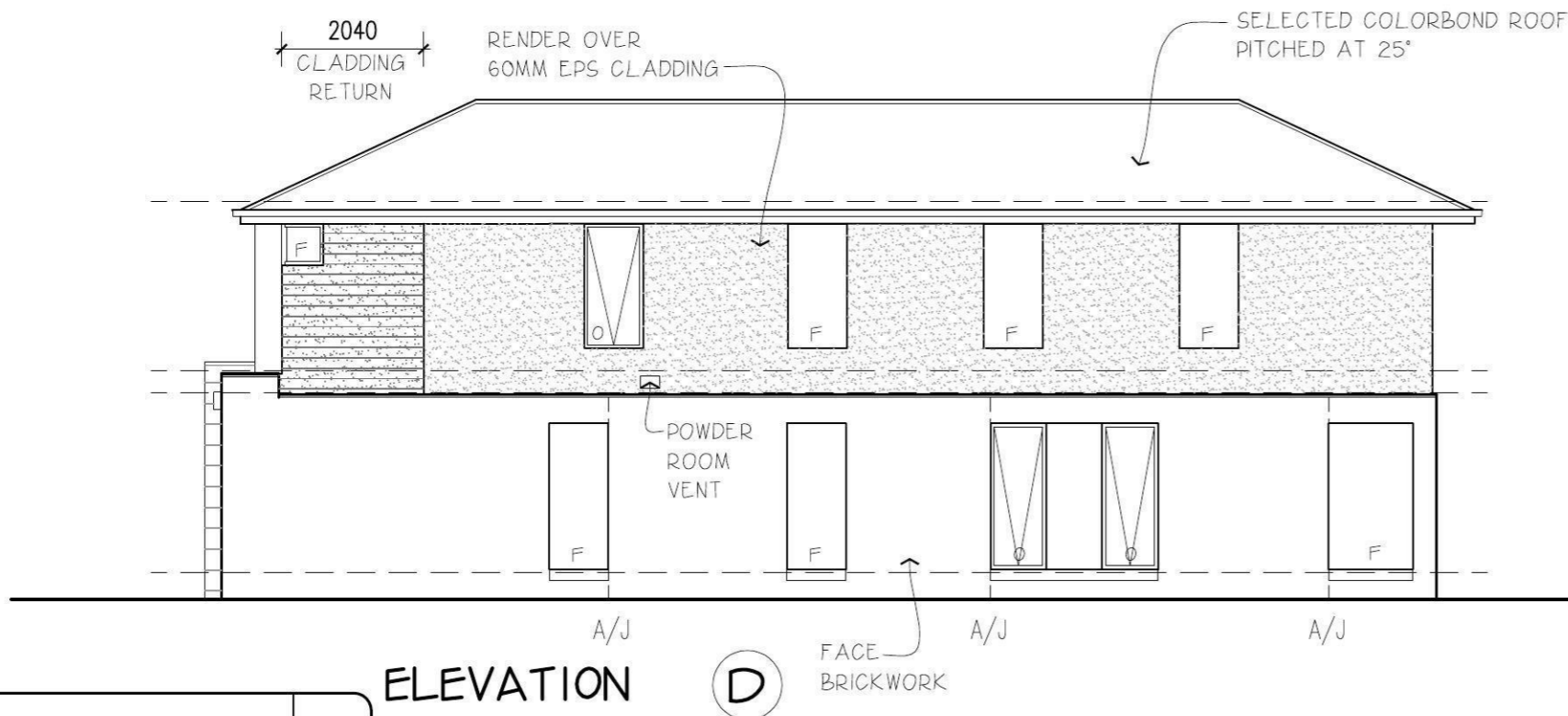

ELEVATION D

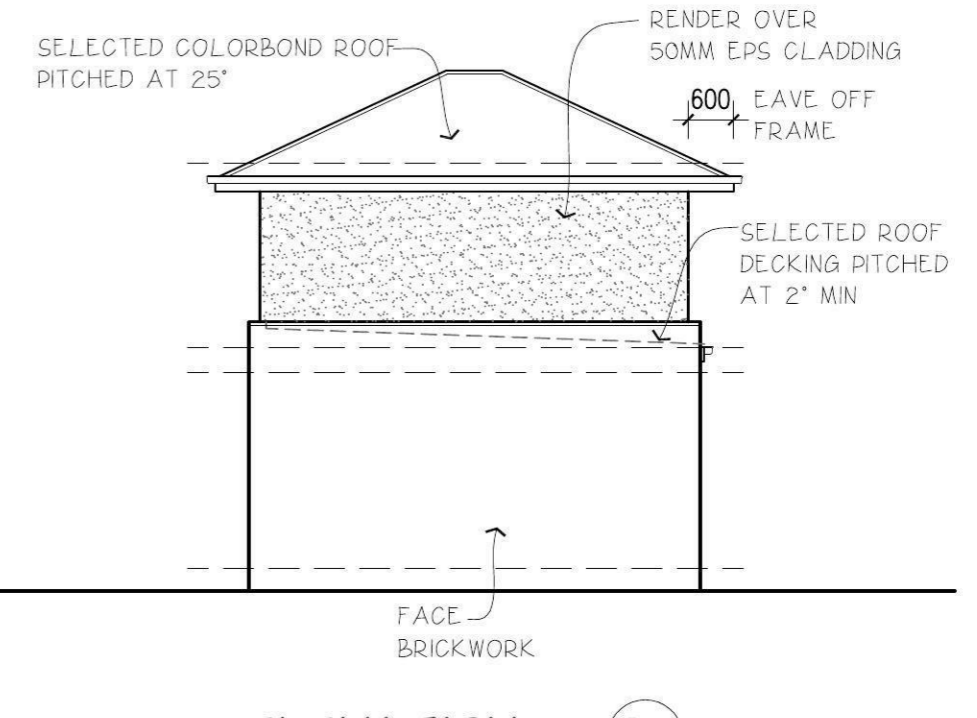

ELEVATION D1

DATE	REVISION	DRAWN

© Henley Arch P/L All rights reserved - this set of drawings is COPYRIGHT. Apart from use by the party to whom this report is addressed for the purpose for which it was requested and any fair dealing as permitted under the Copyright Act no part may be used, reproduced or copied by any means or in any form without prior permission of HENLEY ARCH P/L

ELEVATIONS		SHEET 3A	HAND LH	Townhouse 3 - Stage 3 (7.5m) Modern	EDGEWATER HOMES PO Box 550 Moorebank NSW 1875 Ph: 9623 7526 Fax:9673 5560
DRAWN BK 28/03/2013		For EDGEWATER HOMES			
CHECKED **		At LOT 1271 LAKESIDE PARADE JORDAN SPRINGS			
SCALE 1:100					